

# ML15F PA Horn Loudspeaker

The ML15F 15W PA loudspeaker is suitable for harsh environments with high ambient noise levels. With superior intelligibility and dispersion characteristics combined with an optimised frequency range, the compact ML15F is capable of generating a maximum SPL of 120dB ensuring it is ideal for all applications requiring a robust solution for voice notification.

The ML15F features IP66 & IP67 (Type 4/4X/13) enclosures manufactured from high impact, fire retardant ABS. All models have dual cable entries and large termination areas containing in & out terminals. The 316 stainless steel bracket is ratchet adjustable permitting optimum positioning. Available with 25, 70 and 100V line transformers or in 8 or 16 Ohm low impedance versions. UL & cUL approved for Fire Alarm & Emergency and Professional & Commercial use.

## Features

- 120dB(A) @ 1 m at 1.3Khz (Max)
- 113dB +/-3dB @ 15W @ 1m (Rated)
- 101dB +/-3dB @ 1W @ 1m (Pink)
- Rated power: 15 Watts RMS
- Ingress protection IP66/67 Type 4/4X/13/3R
- Large termination area
- Dual M20 or 1/2"NPT cable entries - adaptors available
- Stopping plug included
- 316 (A4) Stainless steel mounting bracket
- Ratchet adjustable 'U' bracket for 360° positioning
- Duplicate cable terminations
- Fire Alarm & Emergency and Professional & Commercial use

## Approvals

- All models comply with the following standards:
  - UL 1480A (Ed 1)
  - CSA C22.2 No. 205 (Ed 3)
  - EAC compliant: RU D-GB.GA05.B.12595-20
  - Russian Maritime Register of Shipping  
Cert: No. 19.00193.278
  - CSFM listing: 7320-2279:0502
- 
- V070 & V725 models are also approved to:
  - UL 1480 (Ed 6)
  - CAN/ULC-541 (Ed 4)



## Specification

SPL:	101dB +/-3dB @ 1W @ 1m (Pink) 113dB +/-3dB @ 15W @ 1m (Rated) 120dB(A) @ 1m at 1.3KHz (Max)
Rated power:	15 Watts RMS
25/70v line tappings:	15W / 7.5W / 5W / 4W / 2W 25V: z=41.67/83.34/125/156.25/312.5K Ohm 70V: z=326.67/653.34/980/1.225K/2.45K Ohm
70v line tappings:	15W / 7.5W / 3W / 1W z=336.67/653.33/1.6K/4.9K Ohm
100v line tappings:	15W / 7.5W / 3W / 1W z=666.87/1.34K/3.34K/10K Ohm
Low impedance:	8 Ohm or 16 Ohm
Directivity Index:	6.2 @ 1kHz & 16.0 @ 4kHz [dB on-axis]
Frequency range:	300Hz to 8000 Hz
DC Line monitoring:	2.2uF or 4.7uF Capacitor (Transformer version) 470uF Capacitor (Low impedance version)
Ingress protection:	IP66 & IP67 (Third party tested) UL50E/NEMA250: 4/4X/3R/13
Enclosure:	High impact UL94 V0 & 5VA FR ABS
Enclosure colour:	Grey or Red
Cable entries:	2 x M20; 1 x M20 & 1 x 1/2"NPT; 2 x 1/2"NPT supplied with blanking plug
Stopping plugs:	Nylon, Brass, Nickel Plated Brass or Stainless Steel
Terminals:	0.5 - 2.5mm <sup>2</sup> (20-14 AWG) Duplicated terminals
Operating temp:	-40 to +66°C [-40° to +151°F]
Storage temp:	-40 to +70°C [-40° to +158°F]
Relative humidity:	99% at 20°C [68°F] - tropicalised
MTBF V100/V070/V725:	630.69 years / 5,524,861 hours - MIL 217
MTBF R008/R016:	830.22 years / 7,272,727 hours - MIL 217
Weight:	Max: 2.60kg/5.72lbs
Performance data:	
Frequency:	Q Factor: Directivity Index: SPL 15W @ 1m:
500Hz	2.7 4.4 112.2
1000Hz	2.6 4.2 118.0
2000Hz	5.4 7.3 120.5
4000Hz	11.2 10.5 116.5
8000Hz	8.0 9.0 112.6

## Part Codes

Variable:	Identifier:	Description:
Product type:	ML15	15W PA Loudspeaker
Horn type:	F	Flare re-entrant horn
Type:	V100 V070 V725 R008 R016	100V Line 70V Line 25/70V Line 8 Ohm Low impedance 16 Ohm Low impedance
Cable entries: [e]	A B C	M20x1.5 & 1/2" NPT M20x1.5 & M20x1.5 (Default) 1/2" NPT & 1/2" NPT
Stopping plug/ adaptor material: [m]	N B P S	Nylon Brass Nickel plated brass Stainless steel
Bracket material: [s]	1 3 5	316 (A4) Stainless Steel 316 (A4) Stainless Steel with Equipment tag 316 (A4) Stainless Steel with Equipment tag & Duty label
Product version:	A	UL, cUL, CE, EAC, RMRS
Product option:	1	Standard product
Enclosure: [x]	G R	Grey Red
Accessories:	SP65-0001-A4 SP65-0003-A4	Pole Mount Bracket Kit St/St 316 (A4) Sunshade - St/St 316 (A4)

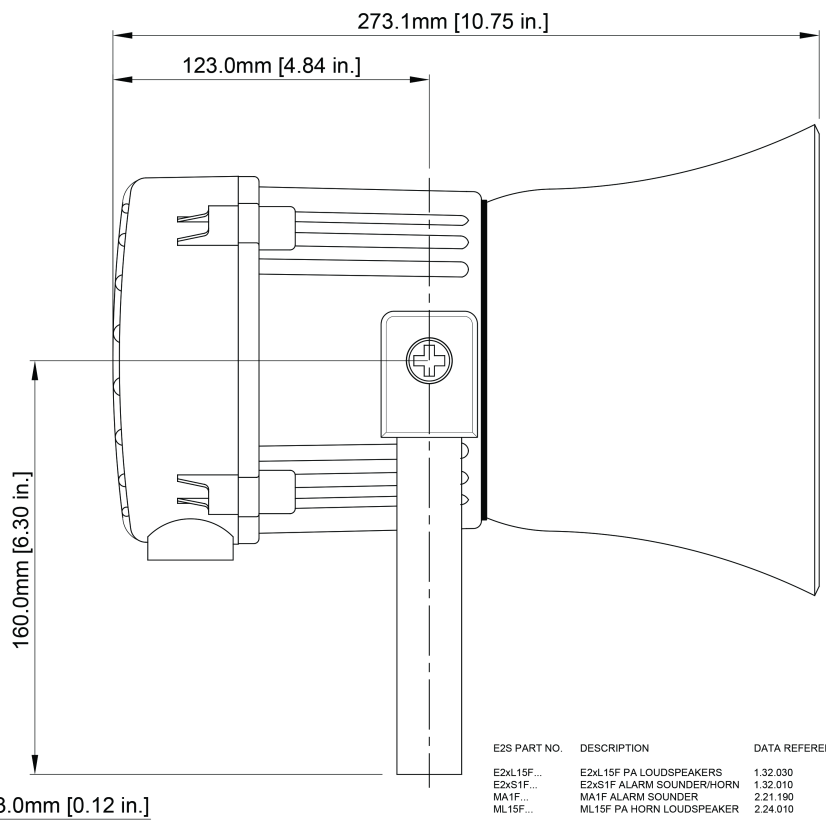
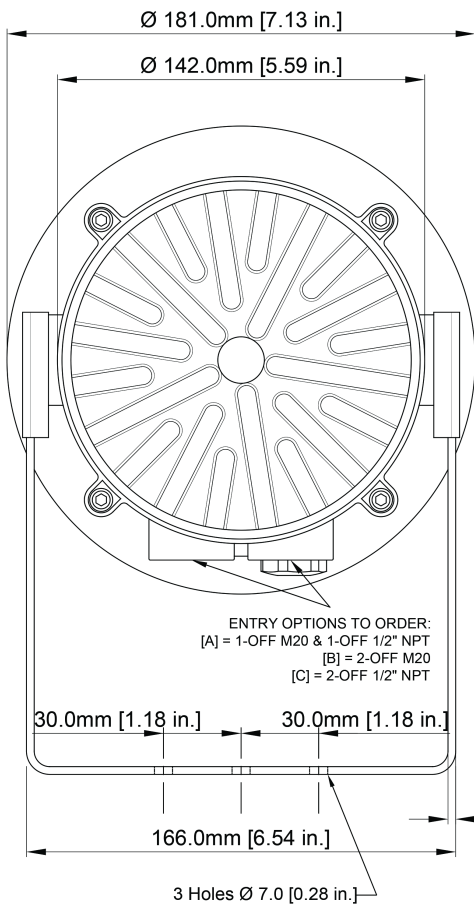

E2S PART NO.	DESCRIPTION	DATA REFERENCE
E2XL15F...	E2XL15F PA LOUDSPEAKERS	1.32.030
E2XS1F...	E2XS1F ALARM SOUNDER/HORN	1.32.010
MA1F...	MA1F ALARM SOUNDER	2.21.190
ML15F...	ML15F PA HORN LOUDSPEAKER	2.24.010

WHERE APPLICABLE UL VERSIONS ARE COVERED BY THIS OUTLINE DRAWING.