

# AB112STR Alarm Horn Sounder & Xenon Strobe

The AB112STR is a high output 120dB(A) alarm horn sounder combined with a powerful 5J Xenon strobe beacon. Featuring 64 alarm tone frequencies and 4 remotely activated stages/channels.

Low current consumption and high SPL in a outdoor rated robust enclosure ensure the AB112STR is suitable for all general signalling applications. Designed to withstand the harshest of environments the AB112STR employs the latest in reliable D Class amplifier technology for superior sound output with low current consumption. The alarm horn sounder & Xenon strobe beacon may be connected for simultaneous or independent operation. The Xenon beacon component features an automatically synchronised flash rate of 1Hz. The DC voltage versions also have user selectable 1.5Hz (90 flashes per minute) and double-strike flash rates.

## Features

- Automatic synchronisation on multi-sounder system
- Synchronised flash rates
- Continuously rated
- Stainless steel fixings
- Unit can be mounted using external lugs or internal fixing positions
- Dual M20 or 1/2"NPT clearance cable entries
- Duplicate pluggable cable terminations - Class A
- Diode polarized for use in supervised circuits
- 64 alarm tone frequencies and 4 remotely activated alarm stages
- Available with custom tone configurations and frequencies
- DC version feature remotely activated second stage beacon mode
- Can be mounted in any orientation

## Approvals

- UKCA
- CE
- EAC: CU TR 04/2011 CU TR 20/2011
- Russian Marine Register of Shipping



## Specification

### Alarm Horn:

Maximum output: High power level: 120dB(A) @ 1 m ±3dB  
[111dB(A) @ 10ft/3m ±3dB]  
Default power level: 117dB(A) @ 1 m ±3dB  
[108dB(A) @ 10ft/3m ±3dB]

Nominal output: High power level: 118dB(A) @ 1m ±3dB  
[109dB(A) @ 10ft/3m ±3dB]  
Default power level: 114dB(A) @ 1m ±3dB  
[105dB(A) @ 10ft/3m ±3dB]

No. of tones: 64 (UK00A / PFEER compliant)

No. of stages: 4

Volume control: Full range to 0dB(A)

Effective range: High power level: 214m/702ft @ 1KHz  
Default power level: 153m/502ft @ 1KHz

In rush: 815mA within 4.0ms @ 24Vdc

Stage switching: Negative (common positive)

### Xenon Beacon:

Energy: 5 Joules (5Ws)

Flash rate: 1Hz (60 fpm)  
DC units: Optionally 1.5Hz  
& double strike

Synchronisation: 1Hz flash rate automatically synchronised

Peak Candela: 500,000 cd - calculated from energy (J)

Effective Intensity cd: 250 cd - calculated from energy (J)

Peak Candela: 49,788 cd\* - measured ref. to I.E.S.

Effective Intensity cd: 125 cd\* - measured ref. to I.E.S.

Lens colours: Amber, Blue, Clear, Green, Red & Yellow

Tube life: Emissions are reduced to 70% after 5 million flashes

### General:

Ingress protection: IP65

Enclosure: High impact UL94 V0 & 5VA FR ABS/PC

Lens colour filter: Field replaceable UV stable PC

Terminals: 0.5 - 2.5mm<sup>2</sup> (20-14 AWG)

Line monitoring: Diode polarized for use in supervised circuits

Operating: -40 to +66°C [-40° to +151°F]

Storage: -40 to +70°C [-40° to +158°F]

Relative humidity: 95% at 20°C [68°F]

Weight DC: 2.00kg / 4.40lbs

Weight AC: 2.30kg / 5.06lbs

## Part Codes

Variable: Identifier: Description:

Product type:	AB112STR	Combined alarm horn sounder & Xenon strobe
Voltage:	DC012	12Vdc (10-15Vdc)
	DC024	24Vdc (20-28Vdc)
	DC048	48Vdc (42-54Vdc)
	AC115	115Vac 50/60Hz
	AC230	230Vac 50/60Hz
Back box/cable entries: [e]	A	Back box with mounting lugs - 2 x M20, 1/2"NPT clearance
Stopping plug material: [m]	A	ABS
Equip. tag/Duty label: [s]	0	No equip. tag or Duty label
	1	316 (A4) St/St Equip. tag/Duty label
	2	Metalised Polyester Equip. tag/Duty label
Product version: [v]	A	RMRS, EAC, CE, UKCA
Product option: [o]	1	Standard product
	Z	Custom alarm tone software - contact E2S
	X	Custom configuration - contact E2S
	Y	Stage control Config. 4 or 8
Enclosure colour: [x]	G	Grey
	R	Red
	S	Special colour - contact E2S
Lens colour: [y]	A	Amber
	B	Blue
	C	Clear
	G	Green
	M	Magenta
	R	Red
	Y	Yellow

### Alarm stage control:

Please review the installation manual and wiring schematics for remote stage control and EOL resistor monitoring configuration options:

Config. 1 or 5 [DC]: Factory default. Common negative, positive switching. Up to 4 Alarm Stages. EOL monitoring Alarm Stage 1 only

Config. 2 or 6 [DC]: User setting. Common positive, negative switching. Up to 4 Alarm Stages. EOL monitoring Alarm Stage 1 only

Config. 3 or 7 [DC]: User setting. Common negative, positive switching activation of Alarm Stages 1 & 2 with EOL on both stages. Reverse polarity monitoring

Config. 4 or 8 [DC]: Product option 'Y'. Independent activation of Alarm Stages 1 & 2 with EOL on both stages. Forward polarity monitoring

Config. 9 or 10 [AC]: Factory default. Up to 4 Alarm Stages. Stage 1 activated at power on. Stages 2, 3 and 4 via volt free contacts

## Current Consumption

Product Version:	Nominal Voltage:	Voltage Range:	Beacon Current:	Horn Default Power Level Current:	Horn High Power Level Current:
DC012	12Vdc	10-14Vdc	600mA	280mA	376mA
DC024	24Vdc	20-28Vdc	300mA	225mA	430mA
DC048	48Vdc	42-54Vdc	250mA	122mA	223mA
AC115	115Vac	103.5-126.5Vac 50/60Hz	70mA	100mA	173mA
AC230	230Vac	207-253Vac 50/60Hz	35mA	64mA	105mA

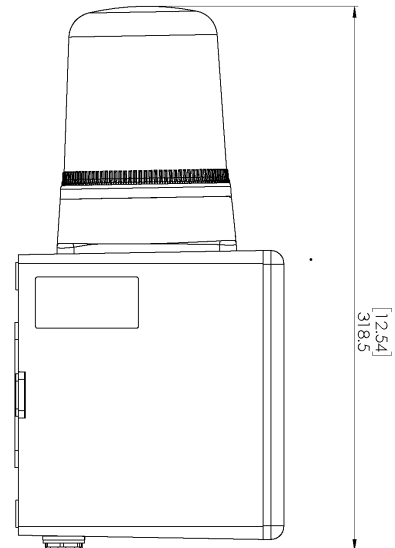
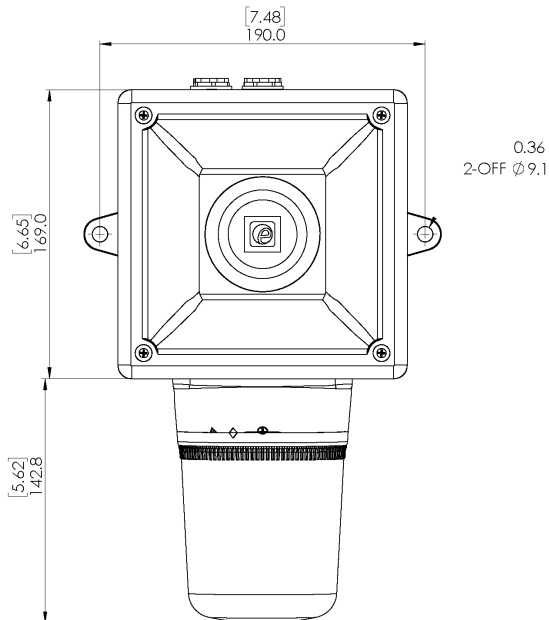
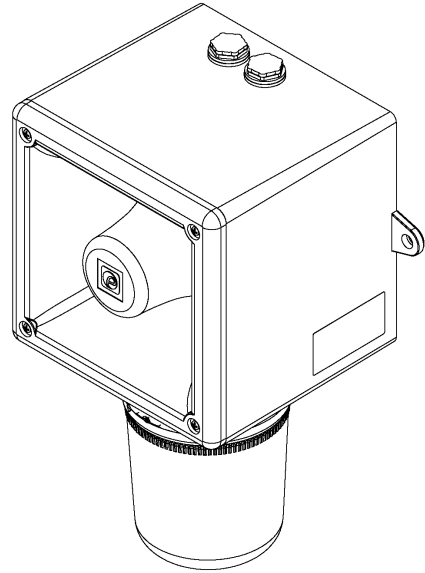
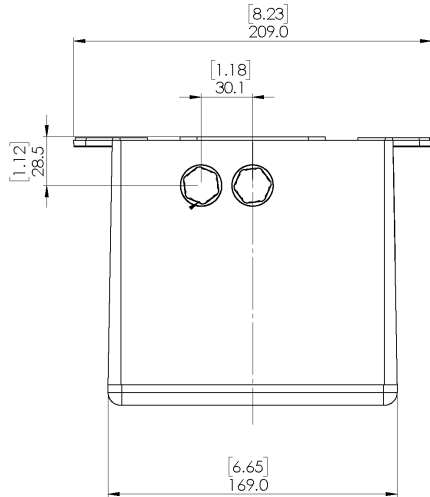

## Tone table

S 1	Description	S 2	S 3	S 4
T 1	1000 Continuous - PFEER Toxic Gas	Any	T 2	T 44
T 2	1200/500 @ 1Hz Sweeping - DIN / PFEER P.T.A.P.	Any	T 3	T 44
T 3	1000 @ 0.5Hz (1s on, 1s off) Intermittent - P...	Any	T 2	T 44
T 4	1.4KH-1.6KHz 1s, 1.6KHz-1.4KHz 0.5s - NF C 48...	Any	T 24	T 1
T 5	544(100mS)/440 (400mS) - NF S 32-001	Any	T 19	T 1
T 6	1500/500 - (0.5s on , 0.5s off) x3 + 1s gap - ...	Any	T 44	T 1
T 7	500-1500Hz Sweeping 2 sec on 1 sec off - AS4428	Any	T 44	T 1
T 8	500/1200Hz @ 0.26Hz(3.3s on, 0.5s off) - NEN ...	Any	T 24	T 35
T 9	1000 (1s on, 1s off)x7 + (7s on, 1s off) - IM...	Any	T 34	T 1
T 10	1000 (1s on, 1s off)x7 + (7s on, 1s off) - IM...	Any	T 34	T 1
T 11	420(0.5s on, 0.5s off)x3 + 1s gap - ISO 8201 ...	Any	T 1	T 8
T 12	1000(0.5s on, 0.5s off)x3 + 1s gap - ISO 8201...	Any	T 1	T 8
T 13	422/775 - (0.85 on, 0.5 off) x3 + 1s gap - ...	Any	T 1	T 8
T 14	1000/2000 @ 1Hz - Singapore	Any	T 3	T 35
T 15	300 Continuous	Any	T 24	T 35
T 16	440 Continuous	Any	T 24	T 35
T 17	470 Continuous	Any	T 24	T 35
T 18	500 Continuous - IMO code 2 (Low)	Any	T 24	T 35
T 19	554 Continuous	Any	T 24	T 35
T 20	660 Continuous	Any	T 24	T 35
T 21	800 Continuous - IMO code 2 (High)	Any	T 24	T 35
T 22	1200 Continuous	Any	T 24	T 35
T 23	2000 Continuous	Any	T 3	T 35
T 24	2400 Continuous	Any	T 20	T 35
T 25	440 @ 0.83Hz (0.60s on, 0.60s off) Intermittent	Any	T 44	T 8
T 26	470 @ 0.9Hz (0.55s on, 0.55s off) Intermittent	Any	T 44	T 8
T 27	470 @ 5Hz (0.10s on, 0.10s off) Intermittent	Any	T 44	T 8
T 28	544 @ 1.14Hz (0.43s on, 0.44s off) Intermittent	Any	T 24	T 8
T 29	655 @ 0.875Hz (0.57s on, 0.57s off) Intermittent	Any	T 44	T 8
T 30	660 @ 0.28Hz (1.80s on, 1.80s off) Intermittent	Any	T 24	T 8
T 31	660 @ 3.3Hz (0.15s on, 0.15s off) Intermittent	Any	T 24	T 8
T 32	745 @ 1Hz (0.50s on, 0.50s off) Intermittent	Any	T 24	T 8

S 1	Description	S 2	S 3	S 4
T 33	800 (0.25s on, 1.00s off) Intermittent	Any	T 24	T 8
T 34	800 @ 2Hz (0.25s on, 0.25s off) - IMO code 3...	Any	T 24	T 8
T 35	1000 @ 1Hz (0.50s on, 0.50s off) Intermittent	Any	T 24	T 8
T 36	2400 @ 1Hz (0.50s on, 0.50s off) Intermittent	Any	T 24	T 8
T 37	2900 @ 5Hz (0.10s on, 0.10s off) Intermittent	Any	T 24	T 8
T 38	363/518 @ 1Hz (0.50s / 0.50s) Alternating	Any	T 8	T 19
T 39	450/500 @ 2Hz (0.25s / 0.25s) Alternating	Any	T 8	T 19
T 40	554/440 @ 1Hz (0.50s / 0.50s) Alternating	Any	T 24	T 19
T 41	554/440 @ 0.65Hz (0.76s / 0.76s) Alternating	Any	T 8	T 19
T 42	561/760 @ 0.83Hz (0.60s / 0.60s) Alternating	Any	T 8	T 19
T 43	780/600 @ 0.96Hz (0.52s / 0.52s) Alternating	Any	T 8	T 19
T 44	800/1000 @ 2Hz (0.25s / 0.25s) Alternating	Any	T 24	T 19
T 45	970/800 @ 2Hz (0.25s / 0.25s) Alternating	Any	T 8	T 19
T 46	800/1000 @ 0.875Hz (0.57s / 0.57s) Alternating	Any	T 24	T 19
T 47	2400/2900 @ 2Hz (0.25s / 0.25s) Alternating	Any	T 24	T 19
T 48	500/1200 @ 0.3Hz (1.67s / 1.67s) Sweeping	Any	T 24	T 12
T 49	560/1055 @ 0.18Hz (2.73s / 2.73s) Sweeping	Any	T 24	T 12
T 50	560/1055 @ 3.3Hz (0.15s / 0.15s) Sweeping	Any	T 24	T 12
T 51	600/1250 @ 0.125Hz (4s / 4s) Sweeping	Any	T 24	T 12
T 52	660/1200 @ 1Hz (0.50s / 0.50s) Sweeping	Any	T 24	T 12
T 53	800/1000 @ 1Hz (0.50s / 0.50s) Sweeping	Any	T 24	T 12
T 54	800/1000 @ 7Hz (0.07s / 0.07s) Sweeping	Any	T 24	T 12
T 55	800/1000 @ 50Hz (0.01s / 0.01s) Sweeping	Any	T 24	T 12
T 56	2400/2900 @ 7Hz (0.07s / 0.07s) Sweeping	Any	T 24	T 12
T 57	2400/2900 @ 1Hz (0.50s / 0.50s) Sweeping	Any	T 24	T 12
T 58	2400/2900 @ 50Hz (0.01s / 0.01s) Sweeping	Any	T 24	T 12
T 59	2500/3000 @ 2Hz (0.25s / 0.25s) Sweeping	Any	T 24	T 12
T 60	2500/3000 @ 7.7Hz (0.65s / 0.65s) Sweeping	Any	T 24	T 12
T 61	800Hz Motor Siren	Any	T 24	T 12
T 62	1200Hz Motor Siren	Any	T 24	T 12
T 63	2400Hz Motor Siren	Any	T 24	T 12
T 64	Simulated Bell	Any	T 21	T 12