

D1xC2X10R 114dB(A) Radial Alarm & 10J Xenon Strobe

The D1xC2X10R is a globally certified alarm horn sounder with a compact, omni-directional horn and combined with a 10 Joule Xenon strobe beacon. The robust Type 4/4X, IP66 marine grade, corrosion proof aluminium enclosure is approved for Class I Div 1, Zone 1, IECEx and ATEX Zone 1, 2, 21 & 22 explosion proof signalling applications.

Featuring 64 alarm tones, each of the 4 stage/channels can be remotely activated. Class D amplification provides a high sound output with a choice of two power modes. The threaded flameproof joint, multiple cable entries and duplicated, pluggable termination simplifies both installation and routine maintenance. The 24Vdc version is approved for public (alarm horn) and private mode fire alarm use (strobe beacon). SIL1 & SIL2 Route 2H compliant to IEC61508 (2010) as standard.

Features

- Maximum sound pressure level output of 114dB(A)
- Choice of 64 alarm tone frequencies.
- 4 remotely selectable alarm stages/channels
- Positive or negative line stage/channel switching
- Automatic synchronisation on multi-beacon & sounder systems
- User selectable strobe flash rates
- Field replaceable lens colour filter
- Ratchet adjustable 316 stainless steel bracket
- Available with custom tone configurations and frequencies
- Robust corrosion proof aluminium enclosure
- Duplicate cable terminations
- UL464 / CAN/ULC-S525 & UL1638 / CAN/ULC-S526

Approvals

- UL/cUL/ULC File ref: E230764
- IECEx Certificate: IECEx ULD 19.0008X
- ATEX Certificate: DEMKO 19 ATEX 2141X
- CSFM listing: 7136-2279:0506
- UKCA certificate: UL21UKEX2132X

Coding

- NEC Class / Zone
 - Class I Zone 1 IIC T3C Gb Ta -55°C to +85°C
 - Class I Zone 1 IIC T4 Gb Ta -55°C to +70°C
 - Class I Zone 1 IIC T4A Gb Ta -55°C to +55°C
 - CEC Class / Zone
 - Class I Zone 1 IIC T4A Gb Ta -55°C to +55°C
 - NEC Class / Div
 - Class I Div 1 ABCD T3C Ta -55°C to +85°C
 - Class I Div 1 ABCD T4 Ta -55°C to +70°C
 - Class I Div 1 ABCD T4A Ta -55°C to +55°C
 - CEC Class / Div
 - Class I Div 1 ABCD T4A Ta -55°C to +55°C
 - IECEx / ATEX
 - II 2G Ex db IIC T3 Gb Ta -55°C to +75°C
 - II 2G Ex db IIC T4 Gb Ta -55°C to +65°C
 - II 2D Ex tb IIIC T137°C Db Ta -55°C to +75°C
- See product manual for full voltage specific coding.



Specification

Alarm Horn:

Maximum output: High power level: 114dB(A) @ 1 m +/- 3dB
[105dB(A) @ 10ft/3m +/- 3dB]
Default power level: 112dB(A) @ 1 m +/- 3dB
[103dB(A) @ 10ft/3m +/- 3dB]

Nominal output: High power level: 109dB(A) @ 1m +/- 3dB
[100dB(A) @ 10ft/3m] +/- 3dB
Default power level: 107dB(A) @ 1m +/- 3dB
[98dB(A) @ 10ft/3m] +/- 3dB

No. of tones: 64 (UK00A / PFEER compliant)

No. of stages: 4

Volume control: Full range

Effective range: 125m/410ft @ 1KHz

Voltages DC: 24Vdc (20-28Vdc)

Voltages AC: 110-120Vac, 220-240Vac

Stage switching: DC units: negative or positive
AC units: common supply line

Strobe Beacon:

Energy: 10 Joules (10Ws)

Flash rates: Option 1: 1Hz (60 fpm)
Option 2: 1.5Hz (90 fpm)
Option 3: Double Strike

Peak Candela: 1,000,000 cd – calculated from energy (J)

Effective Intensity: 500 cd – calculated from energy (J)

Peak Candela: 85,544 cd* – measured ref. to I.E.S.

Effective Intensity: 260 cd* – measured ref. to I.E.S.

Lens colours: Amber, Blue, Clear, Green, Magenta, Red & Yellow

Tube life : Emissions reduced to 70% > 5 million flashes

General:

Safety Integrity Level: SIL1 and SIL2 Route 2H IEC61508 (2010)

Ingress protection: EN60529: IP66/67
UL50E / NEMA250: 4 / 4X / 3R / 13

Enclosure material: Marine grade aluminium LM6 – copper free
Chromated & powder coated – corrosion proof

Enclosure colour: Red or Grey, custom colours available on request

Cable entries: 1x1/2"NPT & 2xM20 – thread adaptors available

Terminals: 0.5 – 2.5mm² (20-14 AWG) Pluggable, duplicated terminals

Grounding stud: M5

Line monitoring: Blocking diode included. EOL Min. 500 Ohm 2W, or 3k3 Ohm
0.5W resistor or diode (DC versions) can be fitted

Enclosure volume: <2 litres

Installation temp: -55 to +85°C [-67° to +185°F]

Storage temp: -55 to +85°C [-67° to +185°F]

Relative humidity: 99%

Vibration test: 35Hz for a duration 4Hr (UL464)

Jarring test: 3ft/lb Energy (UL464)

Impact test: 3x 5lb (UL464)

Relative humidity: 95% – Additional tropicalisation is recommended for
applications where both high relative humidity and high
ambient temperatures exist

Weight: 5.0kg/10.10lbs

Part Codes

Part Code: **Identifier:** **Description:**

Product type: D1xC2X10 Combined Alarm Horn & Xenon Strobe

Horn type: R Omni-directional radial horn

Voltage: DC024 20-28V dc
AC115 110-120Vac
AC230 220-240Vac

Cable entries:[e] A 2 x M20x1.5mm & 1 x 1/2"NPT
B 2 x 1/2"NPT – adaptors
C 2 x 3/4"NPT – adaptors
D 2 x M25x1.5mm – adaptors
F 1 x 3/4"NPT – adaptor
G 1 x M25x1.5mm – adaptor
Note: All entries, excluding thread adaptors, supplied
with stopping plugs installed.

Stopping plug/
adaptor material: B Brass
N Nickel Plated
[m] S Stainless Steel

Bracket/Guard material: [s] 1 U bracket A4 316 Stainless Steel
3 U bracket A4 316 St/St with Equip. Tag
6 Surface bracket A4 316 SS
7 Surface bracket A4 316 SS with Equip. Tag

Product version: A UL, cUL, ULC, IECEx, ATEX, CSFM – SIL1 & SIL2
[v]

Product option: 1 Standard product
[o] Z Custom alarm tone software – contact E2S
X Custom configuration – contact E2S
Y Stage control Config. 4 or 8

Enclosure colour: G Grey
[x] R Red
S Special colour – contact E2S

Lens colour: [y] A Amber
B Blue
C Clear
G Green
M Magenta
R Red
Y Yellow

Accessories:

SP65-0001-A4 Pole Mount Bracket Kit St/St A4 (316)
SP65-0003-A4 Sunshade – St/St A4 (316)

Alarm stage control:

Please review the installation manual and wiring schematics for remote stage control and EOL resistor monitoring configuration options:

Config. 1 or 5 [DC]: Factory default. Common negative, positive switching. Up to 4 Alarm Stages. EOL monitoring Alarm Stage 1 only

Config. 2 or 6 [DC]: User setting. Common positive, negative switching. Up to 4 Alarm Stages. EOL monitoring Alarm Stage 1 only

Config. 3 or 7 [DC]: User setting. Common negative, positive switching activation of Alarm Stages 1 & 2 with EOL on both stages. Reverse polarity monitoring

Config. 4 or 8 [DC]: Product option 'Y'. Independent activation of Alarm Stages 1 & 2 with EOL on both stages. Forward polarity monitoring

Config. 1 or 2 [AC]: Factory default. Up to 4 Alarm Stages. Stage 1 activated at power on. Stages 2, 3 and 4 via volt free contacts

Current Consumption

Voltage range:	Nominal Voltage:	Xenon Strobe Nominal current:	Alarm Horn Default Power Nominal current:	Alarm Horn High Power Nominal current:	Combined Default Power Nominal current:	Combined High Power Nominal current:	Combined Default Power Maximum current:	Combined High Power Maximum current:	In Rush <5ms
20-28Vdc	24Vdc	673mA	324mA	740mA	997mA	1413mA	1091mA	1507mA	786mA
110-120Vac 50/60Hz	115Vac	247mA	125mA	285mA	372mA	532mA	449mA	636mA	
220-240Vac 50/60Hz	230Vac	121mA	78mA	167mA	199mA	288mA	199mA	362mA	

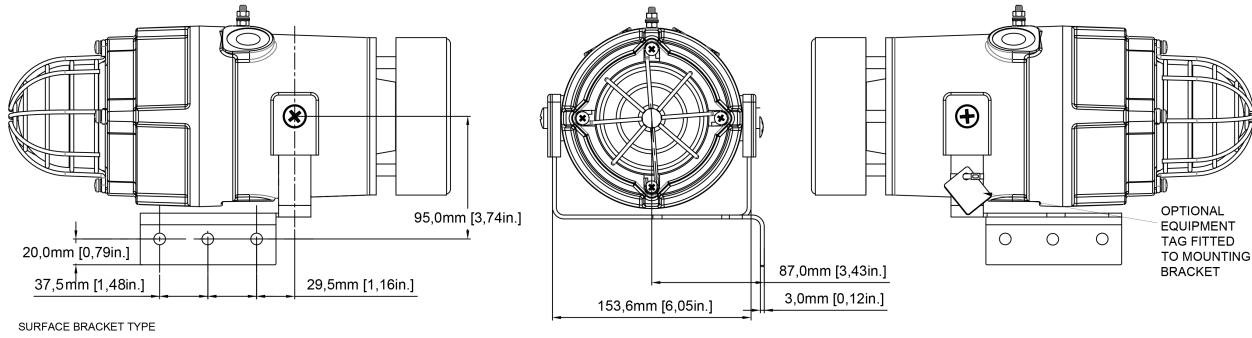

STANDARD BRACKET TYPE

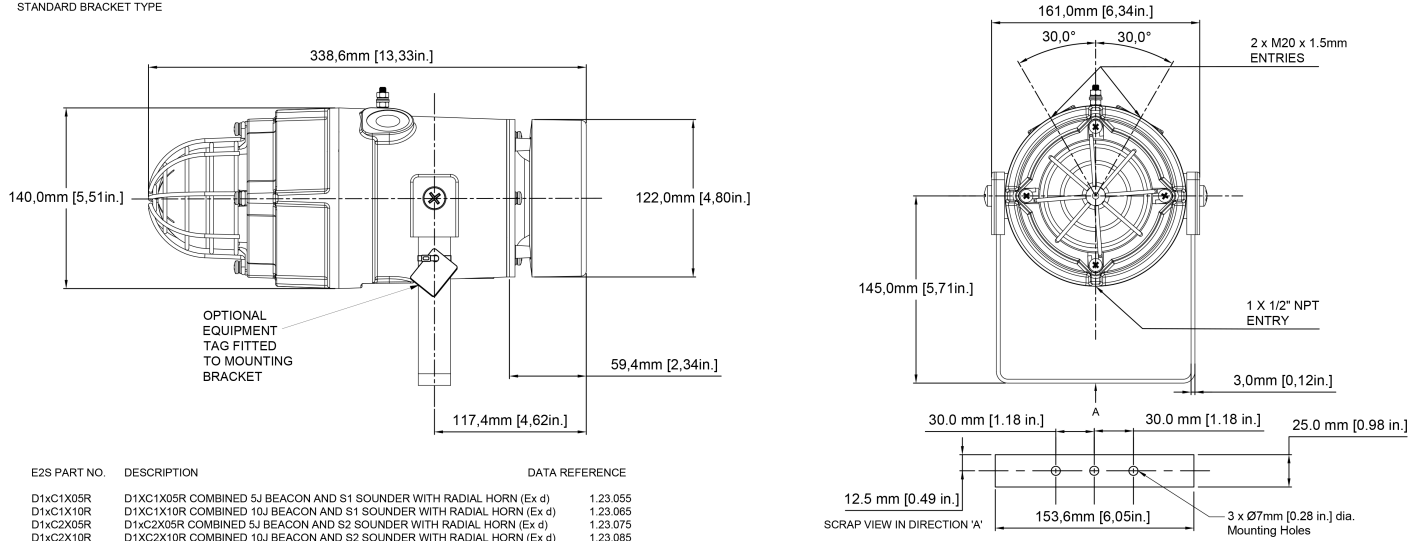

E2S PART NO.	DESCRIPTION	DATA REFERENCE
D1xC1X05R	D1XC1X05R COMBINED 5J BEACON AND S1 SOUNDER WITH RADIAL HORN (Ex d)	1.23.055
D1xC1X10R	D1XC1X10R COMBINED 10J BEACON AND S1 SOUNDER WITH RADIAL HORN (Ex d)	1.23.065
D1xC2X05R	D1XC2X05R COMBINED 5J BEACON AND S2 SOUNDER WITH RADIAL HORN (Ex d)	1.23.075
D1xC2X10R	D1XC2X10R COMBINED 10J BEACON AND S2 SOUNDER WITH RADIAL HORN (Ex d)	1.23.085

Tone table

S 1	Description	S 2	S 3	S 4
T1	1000 Continuous PFEER Toxic Gas	Any	T2	T44
T2	1200/500 @ 1Hz Sweeping DIN/PFEER P.T.A.P.	Any	T3	T44
T3	1000 @ 0.5Hz (1s on, 1s off) Intermittent PFE...	Any	T2	T44
T4	1.4KH-1.6KHz 1s, 1.6KHz-1.4KHz 0.5s NF C 48-265	Any	T24	T1
T5	544(100mS)/440 (400mS) NF S 32-001	Any	T19	T1
T6	1500/500 - (0.5s on , 0.5s off) x3 + 1s gap A...	Any	T44	T1
T7	500-1500Hz Sweeping 2 sec on 1 sec off AS4428	Any	T44	T1
T8	500/1200Hz @ 0.26Hz(3.3s on, 0.5s off) NEN 2575	Any	T24	T35
T9	1000 (1s on, 1s off)x7 + (7s on, 1s off) IMO ...	Any	T34	T1
T10	1000 (1s on, 1s off)x7 + (7s on, 1s off) IMO ...	Any	T34	T1
T11	420(0.5s on, 0.5s off)x3 + 1s gap ISO 8201 Te...	Any	T1	T8
T12	1000(0.5s on, 0.5s off)x3 + 1s gap ISO 8201 T...	Any	T1	T8
T13	422/775 (0.85 on, 0.5 off) x3 + 1s gap NFPA T...	Any	T1	T8
T14	1000/2000 @ 1Hz - Singapore	Any	T3	T35
T15	300 Continuous	Any	T24	T35
T16	440 Continuous	Any	T24	T35
T17	470 Continuous	Any	T24	T35
T18	500 Continuous IMO code 2 (Low)	Any	T24	T35
T19	554 Continuous	Any	T24	T35
T20	660 Continuous	Any	T24	T35
T21	800 Continuous IMO code 2 (High)	Any	T24	T35
T22	1200 Continuous	Any	T24	T35
T23	2000 Continuous	Any	T3	T35
T24	2400 Continuous	Any	T20	T35
T25	440 @ 0.83Hz (0.60s on, 0.60s off) Intermittent	Any	T44	T8
T26	470 @ 0.9Hz (0.55s on, 0.55s off) Intermittent	Any	T44	T8
T27	470 @ 5Hz (0.10s on, 0.10s off) Intermittent	Any	T44	T8
T28	544 @ 1.14Hz (0.43s on, 0.44s off) Intermittent	Any	T24	T8
T29	655 @ 0.875Hz (0.57s on, 0.57s off) Intermittent	Any	T44	T8
T30	660 @ 0.28Hz (1.80s on, 1.80s off) Intermittent	Any	T24	T8
T31	660 @ 3.3Hz (0.15s on, 0.15s off) Intermittent	Any	T24	T8
T32	745 @ 1Hz (0.50s on, 0.50s off) Intermittent	Any	T24	T8

S 1	Description	S 2	S 3	S 4
T33	800 (0.25s on, 1.00s off) Intermittent	Any	T24	T8
T34	800 @ 2Hz (0.25s on, 0.25s off) IMO code 3.a ...	Any	T24	T8
T35	1000 @ 1Hz (0.50s on, 0.50s off) Intermittent	Any	T24	T8
T36	2400 @ 1Hz (0.50s on, 0.50s off) Intermittent	Any	T24	T8
T37	2900 @ 5Hz (0.10s on, 0.10s off) Intermittent	Any	T24	T8
T38	363/518 @ 1Hz (0.50s/0.50s) Alternating	Any	T8	T19
T39	450/500 @ 2Hz (0.25s/0.25s) Alternating	Any	T8	T19
T40	554/440 @ 1Hz (0.50s/0.50s) Alternating	Any	T24	T19
T41	554/440 @ 0.65Hz (0.76s/0.76s) Alternating	Any	T8	T19
T42	561/760 @ 0.83Hz (0.60s/0.60s) Alternating	Any	T8	T19
T43	780/600 @ 0.96Hz (0.52s/0.52s) Alternating	Any	T8	T19
T44	800/1000 @ 2Hz (0.25s/0.25s) Alternating	Any	T24	T19
T45	970/800 @ 2Hz (0.25s/0.25s) Alternating	Any	T8	T19
T46	800/1000 @ 0.875Hz (0.57s/0.57s) Alternating	Any	T24	T19
T47	2400/2900 @ 2Hz (0.25s/0.25s) Alternating	Any	T24	T19
T48	500/1200 @ 0.3Hz (1.67s/1.67s) Sweeping	Any	T24	T12
T49	560/1055 @ 0.18Hz (2.73s/2.73s) Sweeping	Any	T24	T12
T50	560/1055 @ 3.3Hz (0.15s/0.15s) Sweeping	Any	T24	T12
T51	600/1250 @ 0.125Hz (4s/4s) Sweeping	Any	T24	T12
T52	660/1200 @ 1Hz (0.50s/0.50s) Sweeping	Any	T24	T12
T53	800/1000 @ 1Hz (0.50s/0.50s) Sweeping	Any	T24	T12
T54	800/1000 @ 7Hz (0.07s/0.07s) Sweeping	Any	T24	T12
T55	800/1000 @ 50Hz (0.01s/0.01s) Sweeping	Any	T24	T12
T56	2400/2900 @ 7Hz (0.07s/0.07s) Sweeping	Any	T24	T12
T57	2400/2900 @ 1Hz (0.50s/0.50s) Sweeping	Any	T24	T12
T58	2400/2900 @ 50Hz (0.01s/0.01s) Sweeping	Any	T24	T12
T59	2500/3000 @ 2Hz (0.25s/0.25s) Sweeping	Any	T24	T12
T60	2500/3000 @ 7.7Hz (0.65s/0.65s) Sweeping	Any	T24	T12
T61	800Hz Motor Siren	Any	T24	T12
T62	1200Hz Motor Siren	Any	T24	T12
T63	2400Hz Motor Siren	Any	T24	T12
T64	Simulated Bell	Any	T21	T12