

ISSUE	MOD No.	REASON - INITIAL - DATE
A		INTRODUCTION OF PART STC 13-03-12
B		UPDATED TO DUAL DIMS. RSR 25-06-13

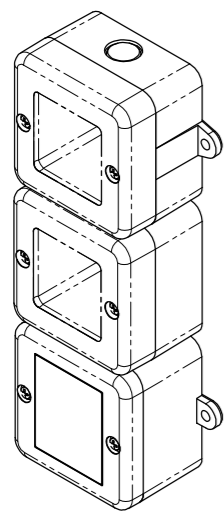
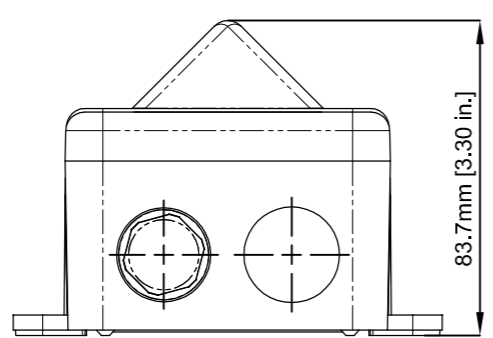
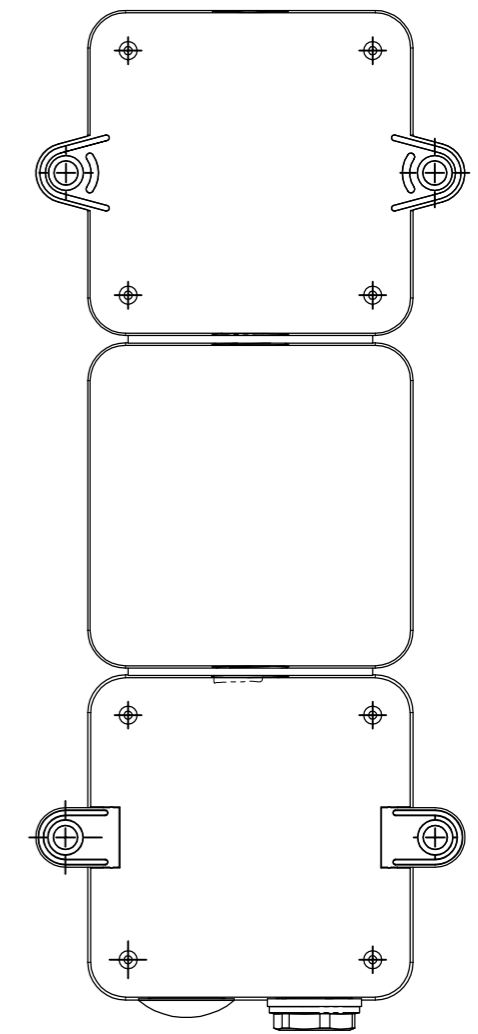
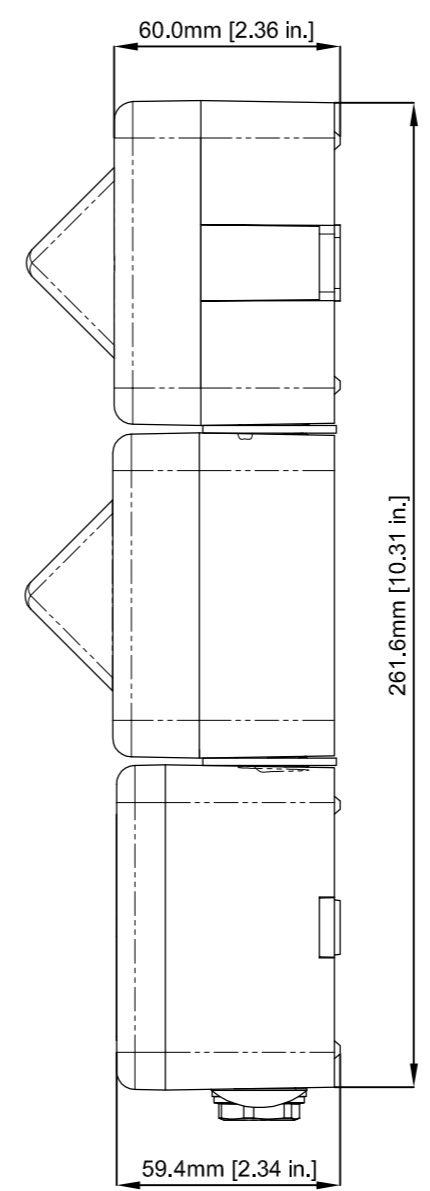
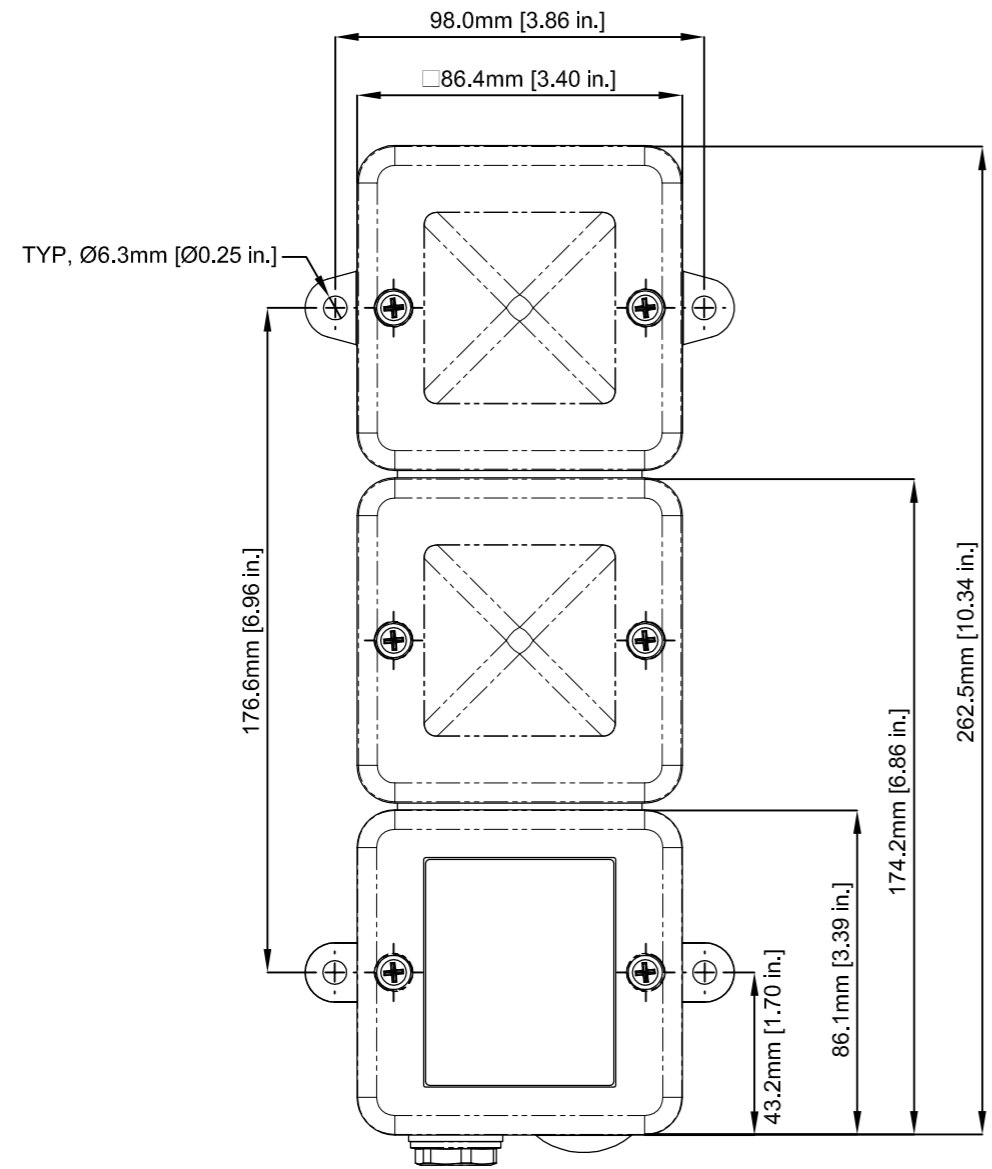

SCALE 1:2

E2S PART NO.	DESCRIPTION	DATA REFERENCE
L101STB2...	STB & ST-L101 STACK UNIT	2.11.010

WHERE APPLICABLE '-UL' VERSIONS ARE COVERED BY THIS OUTLINE DRAWING.

DRAWING TO BS8888:2000 GEOMETRIC TOLERANCES TO ISO1101:1983 LINEAR DIMENSIONAL TOLS ANGULAR DIMENSIONAL TOLS	DRAWN	DATE	SURFACE FINISH	WEIGHT (Kg)	THIS DRAWING AND ANY INFORMATION OR DESCRIPTIVE MATTER THEREIN IS COMMUNICATED IN CONFIDENCE AND IS THE COPYRIGHT PROPERTY OF EUROPEAN SAFETY SYSTEMS LTD. NEITHER THE WHOLE OR ANY EXTRACT MAY BE DISCLOSED, LOANED, COPIED OR USED FOR MANUFACTURING OR TENDERING PURPOSES WITHOUT THEIR WRITTEN CONSENT.	 EUROPEAN SAFETY SYSTEMS LTD IMPRESS HOUSE MANSELL ROAD ACTON LONDON W3 7QH WWW.E2S.COM	ALL DIMENSIONS IN MM IF IN DOUBT, ASK - DO NOT SCALE.		A1				
	CHECKED	DATE								MATERIAL			
STANDARDS	PRODUCT	REF	ALTERNATIVE MATERIAL	EUROPEAN SAFETY SYSTEMS LTD. AS PER LATEST DATE OF ISSUE SHOWN ABOVE						TITLE STB 2 WAY BEACON STACK GA	SCALE 1:1	SHEET 1 OF 1	DRAWING NUMBER SK0214
STB													