

# INSTRUCTION & SERVICE MANUAL

## AL105NSONTELFASH Telephone Alarm Horn & Xenon Strobe

- -25°C to +55C (-13°F to 131°F)
- 1.8Kg (3,96lb)
- CE & UKCA
- GOST-R approved: POCC GB-JB05-H00144
- Sounder Supply: Direct power from telephone line (REN 1)
- Beacon Supply: 230V ac (telephone initiated)
- IP66
- No. of tones: 3 Tone 1 Siren Tone Tone 2 Alternating tone Tone 3 Sweeping tone
- Volume control: Max. 105dB(A); Min. 90dB(A)
- Effect. range: 60m/197ft @ 1KHz
- Energy: 5 Joules (5Ws) Flash rate: 1Hz (60 fpm)
- Peak Candela: 500,000 cd – calculated from energy (J)
- Effect. Intensity cd:250 cd – calculated from energy (J)
- Peak Candela: 78,801 cd\* – measured ref. to I.E.S.
- Effect. Intensity cd:196 cd\* – measured ref. to I.E.S.

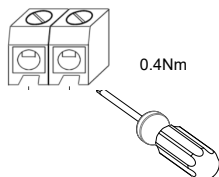
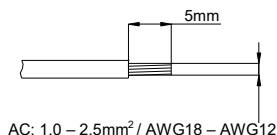
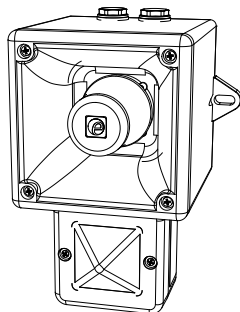

Attention: Installation must be carried out by an electrician in compliance with the latest codes and regulations.

Attention: L'installation doit être effectuée par un électricien conformément aux derniers codes et réglementations.

Achtung: Die Installation muss von einem Elektriker gemäß den neuesten Vorschriften und Bestimmungen durchgeführt werden.

Attenzione: L'installazione deve essere eseguita da un elettricista in conformità con i codici e le normative più recenti.

Atención: La instalación debe ser realizada por un electricista de acuerdo con los últimos códigos y regulaciones.

Atenção: A instalação deve ser realizada por um eletricista de acordo com os códigos e regulamentos mais recentes.

Внимание: установка должна выполняться электриком в соответствии с последними нормами и правилами.

Attention: Disconnect from power source before installation or service to prevent electric shock

Attention: Débranchez-le de la source d'alimentation avant l'installation ou l'entretien pour éviter tout choc électrique.

Achtung: Vor Installation oder Wartung von der Stromquelle trennen, um einen Stromschlag zu vermeiden.

Attenzione: scollegare dall'alimentazione prima dell'installazione o dell'assistenza per evitare scosse elettriche.

Atención: desconéctelo de la fuente de alimentación antes de la instalación o el servicio para evitar descargas eléctricas.

Atenção: Desconecte da fonte de alimentação antes da instalação ou serviço para evitar choque elétrico

Внимание: отключите от источника питания перед установкой или обслуживанием, чтобы предотвратить поражение электрическим током.



(See D247-06-001)

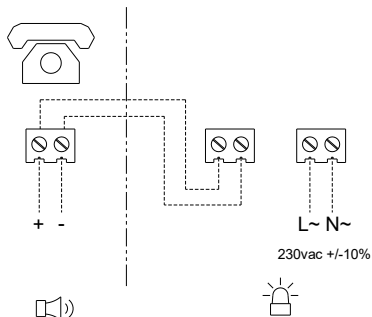

### VOLUME CONTROL

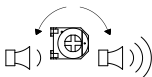

### TONE TABLE

| Tone   | Description      | Waveform  | Level    |
|--------|------------------|---|----------|
| Tone 1 | Siren Tone       |  | 108dB(A) |
| Tone 2 | Alternating tone |  | 104dB(A) |
| Tone 3 | Sweeping tone    |  | 106dB(A) |

dB(A) output figures: +/-3dB(A)

# INSTRUCTION & SERVICE MANUAL

## AL105NSONTELFASH Telephone Alarm Horn & Xenon Strobe

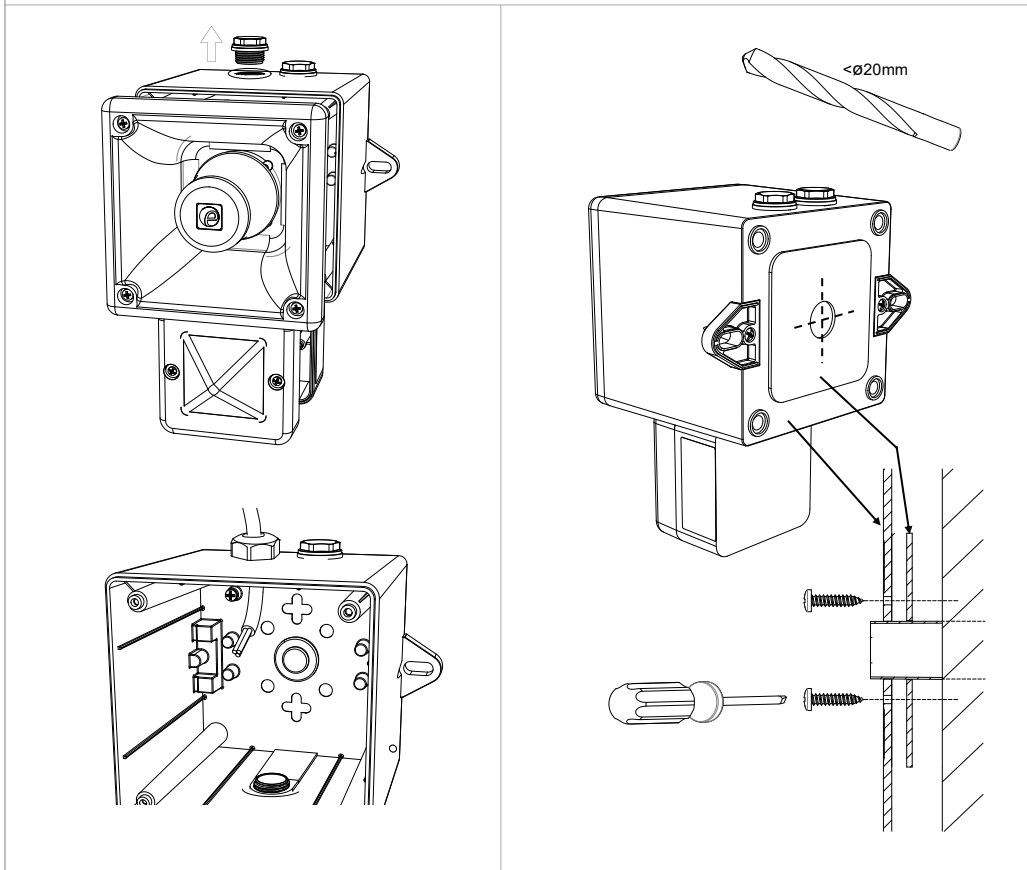
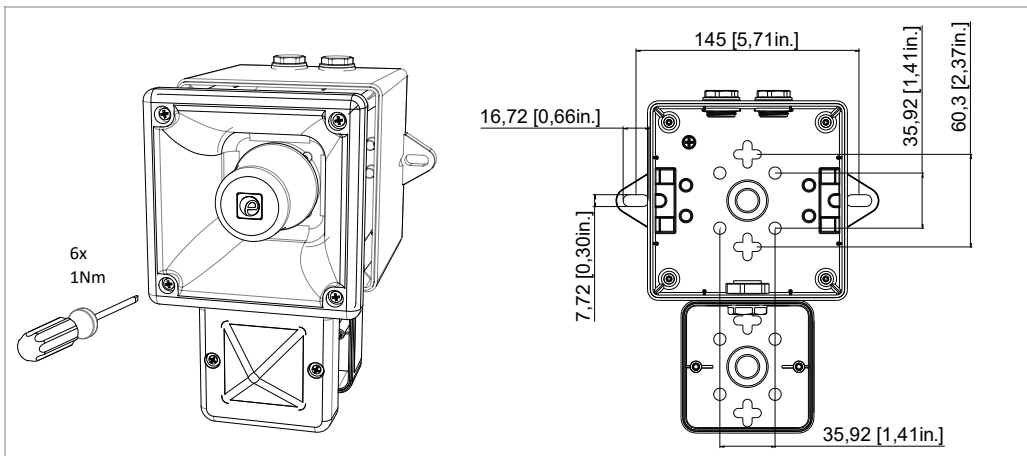

|    |       |         |                               |
|----|-------|---------|-------------------------------|
| 10 | ISSUE | MOD NO. | REASON - INITIAL - DATE       |
| A  | A     |         | INTRODUCTION<br>JS-30/06/2021 |



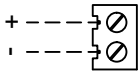

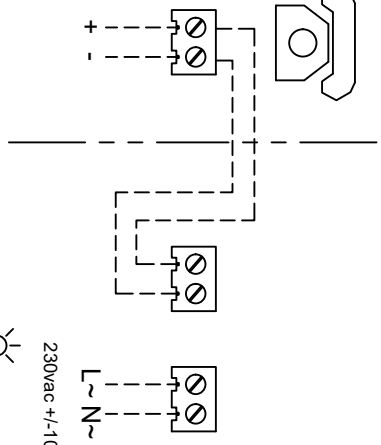
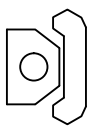

A100/ A105 SONTEL

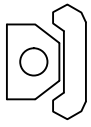
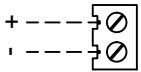

AL100/ AL105 SONTELFASH

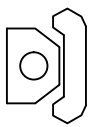
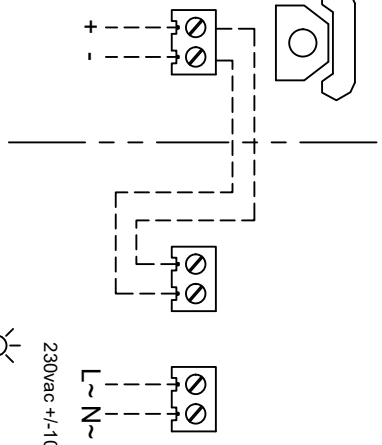

230vac +/-10%

|   |  |   |   |   |                |   |                      |   |  |    |
|---|--|---|---|---|----------------|---|----------------------|---|--|----|
| A | 1  | 2 | 3   | 4 | 5              | 6 | 7                    | 8 | 9  | 10 |
| B | A100/ A105 SONTEL  |   |   |   |                |   |                      |   |  |    |
| C | AL100/ AL105 SONTELFASH  |   |   |   |                |   |                      |   |  |    |
| D | <br><br>  |   |   |   |                |   |                      |   |  |    |
| E | <br><br><br><br>230vac +/-10% |   |   |   |                |   |                      |   |  |    |
| F |   |   |   |   |                |   |                      |   |  |    |
| G | DRAWING TO BS8888:2000<br>GENERAL DIMENSIONS TO ISO1101:1983<br>ANGULAR DIMENSIONAL TOLS   |   | DRAWN<br>J. SPILLER<br>DATE<br>30/06/2021   |   | SURFACE FINISH |   | WEIGHT (KG)          |   | THIS DRAWING AND ANY INFORMATION OR DESCRIPTIVE<br>MATTER THEREIN IS COMMUNICATED IN CONFIDENTIAL<br>SYSTEMS LTD. WHETHER THE WHOLE OR ANY PART MAY<br>BE REPRODUCED OR TRANSMITTED IN ANY FORM OR<br>BY ANY MEANS OR FOR ANY PURPOSES WITHOUT THE<br>WRITTEN CONSENT OF SYSTEMS LTD.<br>REQUESTED DATE OF ISSUE SHOWN ABOVE |    |
| G | STANDARDS<br>SONTEL / FLASHTEL   |   | CHECKED<br>B. ISARD<br>DATE<br>30/06/2021   |   | MATERIAL       |   | ALTERNATIVE MATERIAL |   | EUROPEAN SAFETY SYSTEMS LTD<br><br>MANSELL ROAD<br>LONDON VA 10H<br>WWW.ESS.COM   |    |
| G |  |   | APPROVED<br>R.N.POTTS<br>DATE<br>30/06/2021 |   |                |   |                      |   | ALL DIMENSIONS IN MM<br>IF IN QUOTE ASK -<br>DO NOT SCALE<br>TITLE A100/AL100/A105/AL105 SONTEL /<br>FLASHTEL WIRING SCHEMATIC<br>SCALE SHEET<br>NTS 1 OF 1<br>DRAWING NUMBER<br>D247-06-001   |    |

Page left Intentionally blank