

INSTRUCTION MANUAL
D1xS2FDC024-S & D1xS2HDC024-S
Alarm Horn Sounder – SIL2
Class I, Zone 1, 2, 21 & 22

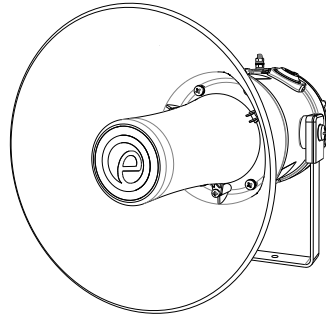

D1xS2FDC024-S

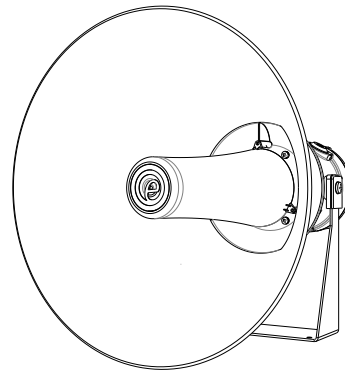

D1xS2HDC024-S

1) Product Table

Model Number	Nominal Input Voltage	Nominal Current P2	Nominal Current P3	Voltage Range	Sound Pressure Level dB(A)	
					Max* P2/P3	Nom.† P2/P3
D1xS2FDC024-S	24Vdc	324mA	740mA	20-28Vdc	120/123	115/118
D1xS2HDC024-S	24Vdc	324mA	740mA	20-28Vdc	124/127	119/122

*Max = Tone 4
†Nom. = Tone 44

The table shows the input current taken by the various sounders.
The current levels shown above are for the 440Hz Continuous tone @ nominal input voltage.
Nominal current at nominal voltage.

Table 1: Electrical Ratings.

2) Warnings



CAUTION

TO REDUCE THE RISK OF IGNITION OF HAZARDOUS ATMOSPHERES:
DISCONNECT FROM SUPPLY BEFORE OPENING.
KEEP TIGHTLY CLOSED WHEN IN OPERATION.

WARNING

FIT SEALING FITTING IN CONDUIT RUNS WITHIN 18 INCHES FROM ENCLOSURE.
EQUIPMENT MUST NOT BE INSTALLED WITH THE HORN FACING UPWARDS OF HORIZONTAL
DO NOT OPEN WHEN AN EXPLOSIVE ATMOSPHERE IS PRESENT
DO NOT OPEN WHEN ENERGISED
POTENTIAL ELECTROSTATIC CHARGING HAZARD - CLEAN ONLY WITH A DAMP CLOTH
ENCLOSURE ENTRIES: TWIN M20 X 1.5 / SINGLE 1/2" NPT
ATEX/IECEx & UKEx INSTALLATIONS: IF TEMPERATURE EXCEEDS 70°C AT ENTRY OR 80°C AT BRANCHING POINT USE SUITABLE RATED CABLE AND GLANDS

ATTENTION

POUR RÉDUIRE LE RISQUE D'INFLAMMATION DES ATMOSPHÈRES DANGEREUSES :
COUPER L'ALIMENTATION AVANT OUVERTURE.
CONSERVER FERMÉ PENDANT LE FONCTIONNEMENT.

AVERTISSEMENT

CONDUITS DOIVENT ÊTRE SCELLES EN MOINS DE 18 POUÇES.
ÉQUIPEMENT NE DOIT PAS ÊTRE INSTALLÉ AVEC LE KLAXON TOURNÉ VERS LE HAUT DE HORIZONTAL.
NE PAS OUVRIR UN PRÉSENCE D'ATMOSPHÈRE EXPLOSIVE
NE PAS OUVRIR ÉNERGIE
DANGER POTENTIEL CHARGE ÉLECTROSTATIQUE - NETTOYER UNIQUEMENT AVEC UN CHIFFON HUMIDE
ENTRÉES DE BÔÎTIER: 2 x M20 X 1.5 / 1 x 1/2" NPT
ATEX/IECEx & UKEx INSTALLATIONS : SI LA TEMPÉRATURE DÉPASSE 70 °C À L'ENTRÉE OU 80 °C AU POINT DE BRANCHEMENT, UTILISER UN CÂBLE ET DES JOINTS D'ÉTANCHÉITÉ APPROPRIÉS

3) Marking & Rating Information

The D1xS2 Alarm Horns comply with the following standards for hazardous locations:

3.1. Class/Division Ratings for US & Canada

Standards	
Class I UL 1203 & CSA C22.2 No 30-M1986	
Class Division Ratings for US (NEC)	
Model No:	Rating
D1xS2F-DC024-S / D1xS2H-DC024-S	Class I Div 1 ABCD T4A Ta -55°C to +85°C Class I Div 1 ABCD T5 Ta -55°C to +80°C Class I Div 1 ABCD T6 Ta -55°C to +65°C
Class Division Ratings for Canada (CEC)	
Model No:	Rating
D1xS2F-DC024-S / D1xS2H-DC024-S	Class I Div 1 ABCD T4A Ta -55°C to +85°C Class I Div 1 ABCD T5 Ta -55°C to +80°C Class I Div 1 ABCD T6 Ta -55°C to +65°C
Class Zone Ratings for US (NEC)	
Model No:	Rating
D1xS2F-DC024-S / D1xS2H-DC024-S	Class I Zone 1 IIC T4A Ta -55°C to +85°C Class I Zone 1 IIC T5 Ta -55°C to +80°C Class I Zone 1 IIC T6 Ta -55°C to +65°C
Class Zone Ratings for Canada (CEC)	
Model No:	Rating
D1xS2F-DC024-S / D1xS2H-DC024-S	Class I Zone 1 IIC T4A Ta -55°C to +85°C Class I Zone 1 IIC T5 Ta -55°C to +80°C Class I Zone 1 IIC T6 Ta -55°C to +65°C
Installation must be carried out in compliance with the National Electric Code / Canadian Electric Code	

3.2. ATEX / IECEx & UKEx Ratings

Standards	
EN60079-0:2018/IEC60079-0:2017 (ed.7): Explosive Atmospheres - Equipment General Requirements. EN60079-1:2014/IEC60079-1:2014 (ed.7): Explosive Atmospheres - Equipment Protection by Flameproof Enclosures "d". EN60079-31:2014/IEC60079-31:2013 (ed.2): Explosive Atmospheres - Equipment Dust Ignition Protection by enclosure "t".	
Model No:	Rating
D1xS2F-DC024-S / D1xS2H-DC024-S	Ex db IIC T5 Gb Ta -55°C to +75°C Ex db IIC T6 Gb Ta -55°C to +60°C Ex tb IIC T95°C Db Ta -55°C to +75°C
See Product table for electrical ratings of each unit model	

Certificate No. DEMKO 19ATEX2141X
IECEX ULD 19.0008X
UKEx UL UL21UKEX2132X

Epsilon x
Equipment Group
and Category:



II 2G
II 2D

CE Marking and
Notified Body No.



2813

UKCA Marking and
Notified Body No.



0518

4) Zones, Gas Group, Category and Temperature Classification

The units can be installed in locations with the following conditions:

Area Classification Gas	
Zone 1	Explosive gas air mixture likely to occur in normal operation.
Zone 2	Explosive gas air mixture not likely to occur in normal operation, and if it does, it will only exist for a short time.
Gas Groupings	
Group IIA	Propane
Group IIB	Ethylene
Group IIC	Hydrogen and Acetylene
Temperature Classification for Gas Applications	
T1	450° C
T2	300° C
T3	200° C
T4	135° C
T5	100° C
T6	85° C (D1xS2FDC024-S/D1xS2HDC024-S up to 60° C ambient)
Area Classification Dust	
Zone 21	Explosive dust air mixture likely to occur in normal operation.
Zone 22	Explosive dust air mixture not likely to occur in normal operation, and if it does, it will only exist for a short time.
Dust Groupings	
Group IIIA	Combustible Dusts
Group IIIB	Non-Conductive Dusts
Group IIIC	Conductive Dusts
Equipment Category	
2G, 2D	
Equipment Protection Level	
Gb, Gc, Db, Dc	
Maximum Surface Temperature for Dust Applications	
95° C (D1xS2FDC024-S/D1xS2HDC024-S)	
Ambient Temperature Range	
-55° C to +75° C (-67° F to +167° F)	
IP Rating	
IP66 to EN60529 4 / 4X / 3R / 13 to UL50E / NEMA250	
Installation must be carried out in compliance with the latest issue of the following standards:	
EN60079-14 / IEC60079-14: Explosive atmospheres - Electrical installations design, selection and erection EN60079-10-1 / IEC60079-10-1: Explosive atmospheres - Classification of areas. Explosive gas atmospheres EN60079-10-2 / IEC60079-10-2: Explosive atmospheres - Classification of areas. Explosive dust atmospheres	

5) Specific Conditions of Installation

ATEX/IECEX & UKEx Installations:

The cable entries have two M20 x 1.5 – 6H entry thread and a single ½" NPT thread. If the installation is made using cable glands, only suitably rated ATEX/IECEX or UKEx certified cable glands must be used. They must be suitable for the type of cable being used and also meet the requirements of the current installation standards EN 60079-14 / IEC60079-14.

If the installation is made using conduit, openings must have a sealing fitting connected as close as practical to the wall of the enclosure, but in no case more than the size of the conduit or 50mm, whichever is the lesser.

Any unused cable entries must be closed with suitably rated and UKEx certified blanking plugs.

For high ambient temperatures the cable entry temperature may exceed 70°C or the cable branching point temperature may exceed 80°C and therefore suitable heat resisting cables and cable glands must be used, with a rated service temperature at least as stated below:

Minimum Ratings of Cables & Cable Glands					
Max Ambient Temp (°C)	55	60	65	70	75
D1xS2FDC024-S/D1xS2HDC024-S Min. Rating (°C)	70	75	80	85	90

Table 2: Min. Ratings of Cables & Cable Glands.

NEC / CEC Installations:

The cable entries have two M20 x 1.5 – 6H entry thread and a single ½" NPT thread. If the installation is made using cable glands, only suitably rated and UKEx certified cable glands must be used. They must be suitable for the type of cable being used and also meet the requirements of the current installation standards for NEC & CEC.

If the installation is made using conduit, openings must have a sealing fitting connected within 18" of enclosure.

Any unused cable entries must be closed with suitably rated and certified blanking plugs.

All Installations:

The plastic horn is not anti-static and the metallic enclosure has a non-conductive coating. These may generate an ignition-capable level of electrostatic charges under certain extreme conditions. The user should ensure that the equipment is not installed in a location where it may be subjected to external conditions that might cause a build-up of electrostatic charges on non-conducting surfaces.

Only the explosionproof cover is to be used for access to the enclosure for installation, service and maintenance.

6) Specific Conditions for Safe Use

Flameproof threaded joints and cemented joints are not permitted to be repaired.

7) Product Mounting and Access

7.1. Mounting

The D1x Alarm Horn may be secured to any flat surface using at least two of the three or four 7mm fixing holes. The enclosure provides IP66 protection and is suitable for installation in exterior locations providing it is positioned so that water cannot collect in the horn, and the cable entry is sealed.

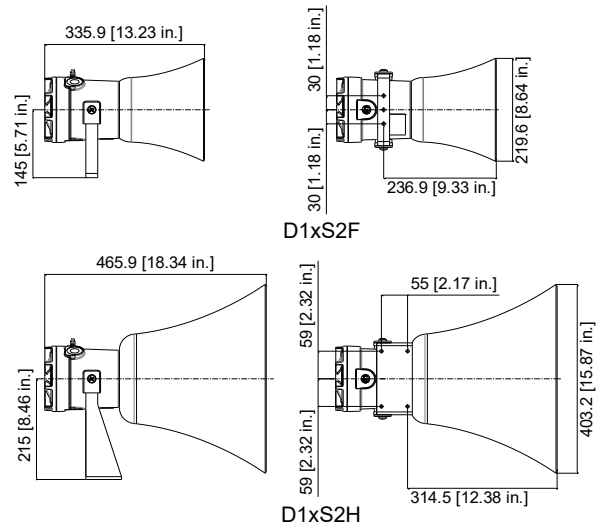
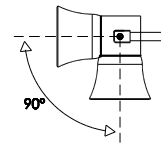

Fig 1: Mounting Locations

The Equipment must not be installed with the horn facing upwards of horizontal.



7.2. Installation procedure

- Secure the D1x unit to a flat surface via the three 7mm fixing holes in the mounting bracket.
- Remove the explosionproof cover of the alarm horn by unscrewing it, taking care not to damage the explosionproof threads in the process (Refer to section 7.4).
- Fit an M20/NPT suitably rated cable gland or conduit entry into the hole in the enclosure and connect the field wiring to the appropriate alarm horn terminals as shown in D190-06-651. The power supply terminals are duplicated so that units may be connected in parallel. An end of line monitoring resistor may be fitted to DC units only (see section 10). If the second and third M20/NPT entries are not used, suitably rated stopping plugs must always be fitted.
- Replace the explosionproof cover of the loudspeaker, taking care not to damage the explosionproof threads. Tighten fully.

7.3. Hornless Variants

The D1x Sounder is also available as a variant with no horn fitted in the factory. The Horn threaded nose portion has a fitment thread of 1-3/8" – 18 UNF (to BS1580 or ANSI B1.1). The customer is responsible for sourcing and correctly fitting a suitable horn that meets all of the relevant safety requirements.

7.4. Access to the Explosionproof Enclosure

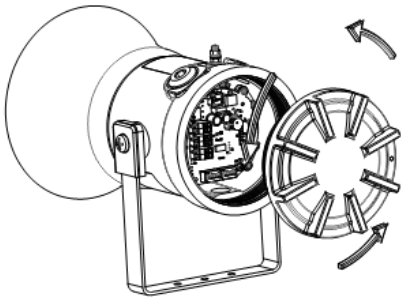

Fig 2: Accessing the enclosure

To access the Ex d chamber, loosen the M4 grub screw on the sounder cover. Open the enclosure by turning the sounder cover counterclockwise and remove the cover. Take extreme care not to damage the explosionproof threads in the process.

On completion of the installation the flameproof threaded joint should be inspected to ensure that they are clean and that they have not been damaged during installation.

Ensure the O-ring seal is in place and undamaged.

When fitting the flameproof cover ensure the thread is engaged correctly. Fully tighten the cover all the way, ensure no gap is visible between the cover and base of the sounder enclosure.

8) Installation Requirements

8.1. Safe Installation Requirements



Warning – High voltage may be present, risk of electric shock.
DO NOT open when energised, disconnect power before opening.

The sounder must only be installed by suitably qualified personnel in accordance with the latest issues of the relevant standards.

The product must only be installed by suitably qualified personnel in accordance with the latest issues of the relevant standards.

The installation of the units must also be in accordance with the NEC / CEC and any local regulations and should only be carried out by a competent electrical engineer who has the necessary training.

8.2. Cable Selection and Connections

Electrical connections are to be made into the terminal blocks on the PCBA, using solid wire 0.5-4mm² / AWG 20-12 or stranded wire, sizes 0.5-2.5mm² / AWG 24-14. Wire insulation needs to be stripped 8mm. Wires may be fitted securely with crimped ferrules. Terminal screws need to be tightened down with a tightening torque of 0.45 Nm / 3.5 Lb-in.

When selecting the cable size, consideration must be given to the input current that each unit draws (see table 1), the number of sounders on the line and the length of the cable runs. The cable size selected must have the necessary capacity to provide the input current to all the sounders connected to the line.

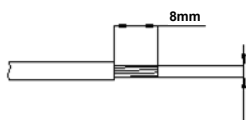

DC: 0.2 - 2.5mm² / AWG24 - AWG12

Fig 3: Wire Preparation.

When connecting wires to the terminals great care should be taken to dress the wires so that when the cover is inserted into the chamber the wires do not exert excess pressure on the terminal blocks. This is particularly important when using cables with large cross-sectional areas such as 2.5mm².

8.3. Earthing

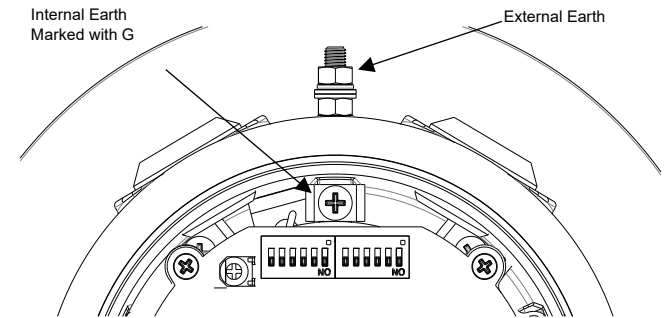

Fig. 4 Earth Locations

The unit has both a primary internal and secondary external earth fixing point.

Internal earthing connections should be made to the Internal Earth terminal in the base of the housing using a ring crimp terminal to secure the earth conductor under the earth clamp. The earth conductor should be at least equal in size and rating to the incoming power conductors but at least a minimum of 0.82mm² / 18AWG in size.

External earth connections can be made to the M5 earth stud (see Fig. 4), using a ring crimp terminal to secure the earth conductor to the earth stud. The external earth conductor should be at least 4mm² in size.

The external earth crimp ring should be located between the two M5 plain washers provided and securely locked down with the M5 spring washer and M5 nut.

8.4. Cable Glands, Blanking Elements & Adapters

Ingress Protection

If a high IP (Ingress Protection) rating is required then a suitable sealing washer must be fitted under the cable glands or blanking plugs. A minimum ingress protection rating of IP6X must be maintained for installations in explosive dust atmospheres.

To maintain the ingress protection rating and mode of protection, the cable entries must be fitted with suitably rated cable entry and/or blanking devices during installation.

If entries are fitted with adaptors they must be suitably rated for the application. Fitting of blanking elements into adaptors is not permitted.

Adapters

The D1x sounder range can be supplied with the following types of adapters:

M20 to 1/2" NPT
M20 to 3/4" NPT
M20 to M25

It is important to note that stopping plugs cannot be fitted onto adapters, only directly onto the M20 entries.

9) Settings

Following illustrations show the settings available for D1xS2 Alarm Horn Sounders. See schematic diagram D190-06-651 for details.

9.1. Configuration

See Table 1 for product power supply and Sound Pressure Levels (SPL).

Configuration for DC Units

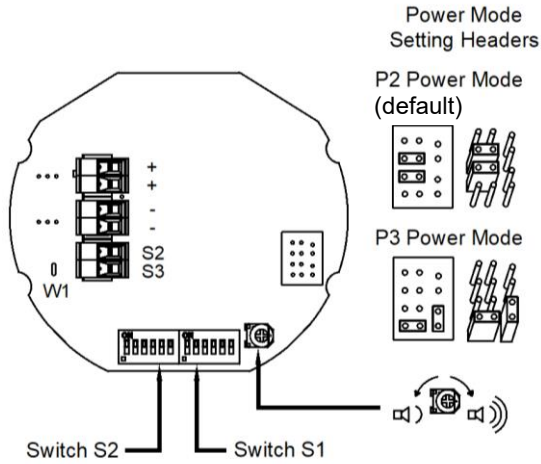

Fig 5: DC PCBA.

9.2. Stage Switching Polarity (DC Units)

Switching from positive switching (default) to negative switching - DC Only.

NOTE: Max supply is 33V DC – if higher DC voltage is required, use Negative switching.

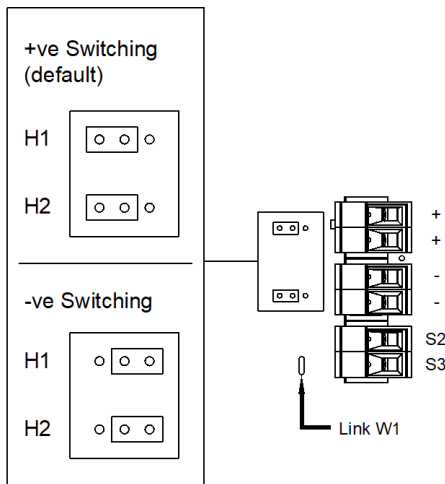
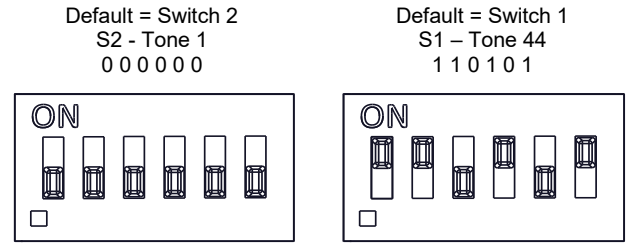

Fig 6: Stage Switching Polarity.

9.3. Tone Selection

The D1x Alarm Horn Sounders have 64 different tones that can be selected independently for the first and second stage alarms. The tones are selected by operation of the tone setting DIP switch 1 & DIP switch 2 (see fig 7) on the PCB, for stage 1 and stage 2 respectively.



(ON = 1, OFF = 0)

Figure 7: DIP switch configuration

The sounder can also be switched to sound the third and fourth stage alarm tones.

The tone table (D221-95-651-IS) shows the switch positions for the 64 tones on first and second stages and which tones are available for the third and fourth stages dependent on the Stage 1 DIP switch setting.

Following table (Table 3) is a summary of DC: D190-06-651 for wiring options.

Config.	Voltage	Configuration Description	Features	Product Option Identifier
1a	DC	Single Stage Configuration	<ul style="list-style-type: none"> Line monitoring Positive Switching 	1
1b	DC	Two Stage Configuration	<ul style="list-style-type: none"> Common Negative Positive Switching 	1
1c	DC	Three/Four Stage Configuration	<ul style="list-style-type: none"> Common Negative Positive Switching 	1
2	DC	Three/Four Stages. Voltage Free 2nd, 3rd & 4th Stage Activation Configuration	<ul style="list-style-type: none"> Common Positive Customer Set H1 & H2 to Negative Switching 	1

Table 3: Summary of Wiring Options. See Document D190-06-651 for DC Schematic Diagrams.

10) End of Line Monitoring (DC Units)

10.1. Standard DC End Of Line Monitoring

All DC units have a blocking diode fitted in their supply input lines. An end of line monitoring diode or an end of line monitoring resistor can be connected across the +ve and -ve terminals in the flameproof chamber. If an end of line resistor is used it must have a minimum resistance value of 3k3 ohms and a minimum wattage of 0.5W or a minimum resistance value of 500 ohms and a minimum wattage of 2W.

The resistor must be connected directly across the +ve and -ve terminals as shown in the following drawing. The resistor leads should be kept as short as possible.

SIL2 line monitoring module product version: see section 20 for standard default values and product coding. See document D190-06-651 for associated wiring diagram.

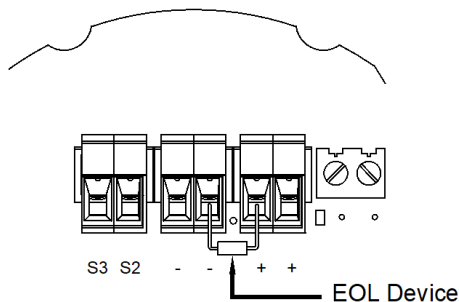

Figure 8: End of Line Resistor placement.

Note that the maximum forward polarity monitoring voltage is 6V. A monitoring voltage greater than 6V may activate the alarm horn sounder and the 2nd, 3rd or 4th stages.

11) Maintenance, Overhaul and Repair

Maintenance, repair and overhaul of the equipment should only be carried out by suitably qualified personnel in accordance with the current relevant standards:

For ATEX/IECEX or UKEx:

EN60079-19/IEC60079-19

Explosive atmospheres – Equipment repair, overhaul and reclamation

EN 60079-17/IEC60079-17

Explosive atmospheres – Electrical installations inspection and maintenance

Units must not be opened while an explosive atmosphere is present.

If opening the unit during maintenance operations, a clean environment must be maintained and any dust layer removed prior to opening the unit.

Potential electrostatic charging hazard – Clean only with a damp cloth.



· All models are approved for use as Audible Signal Appliance for use as General Signaling: UL464A & CSA C22.2 No 205-17

· Type 4 / 4X / 3R / 13, IP66

· -55°C to +85°C / -67°F to +176°F

General Signaling Canada:

D1xS2-DC024-A, D1xS2-DC024-S: -55°C to +85°C / -67°F to +185°F

· To maintain Ingress Protection, cable entries must be fitted with suitably rated cable glands or stopping plugs

· EOL Monitoring (DC Only): End of Line Devices may be fitted between the +ve & -ve terminals of the PCBA. Please ensure that the device legs meet the wire size range stated for the connection terminals and are fitted correctly in order to avoid a short. Refer to the compatible control panel specification for EOL device values and ratings

Model	Nominal Voltage	Voltage Range	P1 Nominal Operating Current [#]	P2 Nominal Operating Current [#]	P3 Nominal Operating Current [#]	P1 Max Operating RMS [*]	P2 Max Operating RMS [*]	P3 Max Operating RMS [*]
D1xS2-DC024-A / D1xS2-DC024-S	12V dc	11.5 - 54V dc	-	289mA	359mA	-	324mA	740mA
	24V dc		-	324mA	740mA			
	48V dc		-	195mA	391mA			

*Max Operating current for worst-case input voltage; Nominal current at nominal voltage and Tone 12

Table 4: UL General Signaling Electrical ratings

12) SIL 2 Instruction/Safety Manual

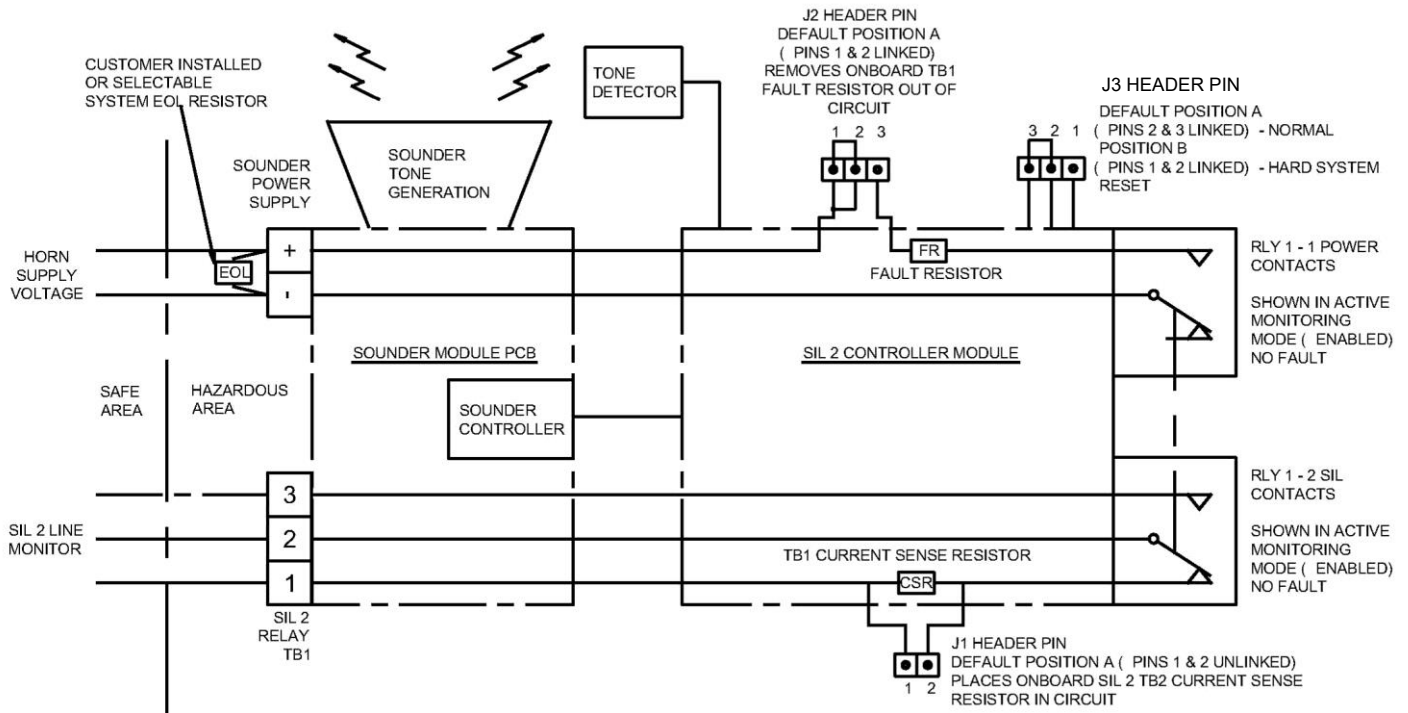

Figure 9 - The SIL 2 Module monitors the Sounder and interfaces to the customer plant.

Warning – To maintain the integrity of the SIL 2 units the system must be installed, commissioned and used within the parameters outlined in this manual. Failure to comply could result in an unintended unit operation or function.

Warning – The unit must be powered in either Standby or Active modes to comply with the SIL 2 approval requirement. If the power is disrupted the unit must be allowed to go through the commissioning cycle to reset. Failure to complete the commissioning cycle and continued disruption in the power supply will generate a fault state which will require the sounder to be reset (see section 16-4).

Warning – Only the alarm tones specified in section 15 may be selected for use in SIL2 compliant systems.

SIL 2 System Description

The SIL 2 module monitors the function of the device and provides feedback to the control panel. A fault condition can be communicated by two methods:

- 4 wire installation can be seen as per section 16-1. A SIL 2 system wiring for fault detection in standby and active mode with independent fault contacts.
- 2 wire installation can be seen as per section 16-2. A SIL 2 system by the introduction to the monitoring circuit and linking in an end of line resistor can only register the fault in standby mode.

13) SIL 2 System Terms and Function

The SIL 2 Sounder Unit Monitors

- Standby mode and Active mode
- Health status of power supply
- Sounder correct function and tone pattern

The SIL 2 sounder operates as part of a SIL 2 system. The sounder will after commissioning remain powered in **Standby mode** (reverse polarity) until the sounder is required to operate. When the signaling device is required to operate the polarity is changed to normal supply and the sounder will go into **Active mode** where it will start to sound the correct tone. When periodically testing the system and sounders operation is put into **Active mode**.

The system panel or PLC will control whether the system is in either of the main two operational modes.

Standby Mode – This is where the power supply polarity is reversed so negative (–ve) is feed to the positive (+) sounder terminal and positive (+) is feed to the negative (–ve) sounder terminal.

In Standby mode the sounder will not sound the tone but the SIL 2 unit is monitoring power supply and is set-up ready to go to Active (alarm) mode.

Power relay RLY1-1 will be open whilst SIL 2 relay RLY1-2 will be closed contact between terminals 1 & 2.

If power is disrupted the SIL 2 unit will go into **Fault mode**, in fault mode the Power relay RLY1-1 will close whilst SIL 2 relay RLY1-2 will become open circuit between terminals 1 & 2.

Active Mode – This is where the power is in normal polarity, positive (+) supplied to the positive (+) sounder terminal and negative (–ve) is supplied to the negative (–ve) sounder terminal.

In Active mode the alarm horn sounder will output the selected alarm tone. The SIL 2 module checks for the correct alarm tone output and the functionality of the alarm tone signal generation process.

Power relay RLY1-1 will be open whilst SIL 2 relay RLY1-2 will be closed contact between terminals 1 & 2.

The SIL 2 unit will also check for signal polarity.

If a fault is found the SIL 2 unit will go into **Fault mode**.

If power is disrupted the SIL 2 unit will go into **Fault mode**, in fault mode the Power relay RLY1-1 will close whilst SIL 2 relay RLY1-2 will become open be circuit between terminals 1 & 2.

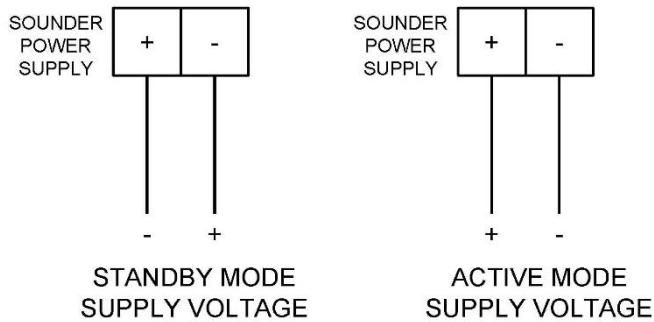

Commissioning System - Functional start-up of System (Normally in reverse polarity mode)

When Commissioning system the power must not be disrupted to the SIL 2 Unit within the unit's initialization cycle which is **5 seconds**.

Once past this period the SIL 2 system is fully operational and will be in monitoring the sounder and power in Standby mode.

The relay RLY1-2 on the SIL 2 unit will only remain open for a maximum of 1 second on commissioning start-up. RLY1-2 will subsequently close contacts 1 & 2 indicating healthy operation. Contact 1 & 2 will only remain open in the event of a fault or a loss of power.

System Testing (Active Mode normal polarity)

The SIL 2 system will remain monitoring the power in standby mode until the polarity is changed to normal mode to enable an active system for sounder functional testing.

Important - The polarity must be held in active mode for a period in excess of **15 seconds** to ensure a full system check is performed.

Once the test period has been completed the unit can be switched back to standby mode by reversing the polarity.

If no faults have been found during the test the relays will remain in steady state.

The SIL 2 unit will continue to monitor the power and module function.

Important - The automated test cycle **must** be undertaken on at least a weekly basis to maintain the SIL 2 units reliability.

System Activation (Active Mode normal polarity)

The SIL 2 system will remain monitoring the power in standby mode until the polarity is changed to Active mode to enable an active system for sounder to function as a warning signaling device.

Important :- The polarity must be held in active mode for a period in excess of 15 seconds to ensure a full system check is performed whilst in alarm mode, although it is expected that during a system activation this period will be significantly greater.

Note :- The fault indication signal on TB1 can take up to 50 milliseconds to indicate system fault.

Fault modes - The fault modes listed 13-1 & 13-2 below will make the SIL 2 unit change the state for relays RLY1-1 and RLY1-2.

In fault mode the Power relay RLY1-1 will close whilst SIL 2 relay RLY1-2 will become open circuit between terminals 1 & 2.

13-1 Sounder Failure

- Tone Failure – No Tone detected
- Sounder Controller failure – No tone generation pulse detected
- Tone Rate Failure – Regular tone cycle erratic

13-2 Power Failure / SIL 2 Failure

- SIL 2 Controller failure – Internal function and system checking flags fault
- Rapid Power cycling – System indicates power instability
- Total Power Failure

It is possible to reset these faults if they were transitory.

Resetting Failure (by power cycling) - It is possible that the SIL 2 unit can be reset by powering the unit off for a period greater than 20 seconds. On restarting the unit and running through the commissioning cycle the fault may clear.

Resetting Failure (by Hard Reset) - It is possible that the SIL 2 unit can be reset by hard resetting the unit using the reset jumper within the unit (see section 16-4) on hard resetting.

On restarting the unit and running through the commissioning cycle, the fault may clear. It is necessary to run the test function cycle again to see if the fault is still evident.

If the hard reset process does not correct the latched fault the alarm horn sounder may require further investigation, please contact your local E2S representative.

14) SIL 2 Wiring configuration and Sounder set-up

J3 Header – Hard Reset
Shown in factory default position A (see section 16-4), set to Normal operation

Sounder Supply Terminals

SIL Relay Terminals TB1

J1 Header – Current Sense Resistor (CSR)
Shown in factory default position A (see section 16-3), places SIL TB1 Current sense resistor in circuit.

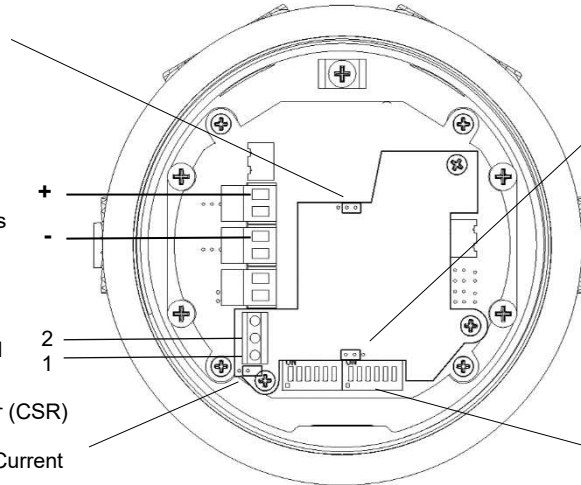

J2 Header – Fault Resistor (FR)
Shown in factory default position A (see section 16-3) removes power supply terminal block. Fault resistor & relay RLY 1-1 out of circuit.

DIP Switch Tone Selection

Figure 10 – Terminals and header pins for sounder

Power & Communication with the system control panel can be configured in two ways: - Although it is **highly** recommended that the unit is wired as stated in this section 16-1 as a 4 – Wire System.

15) SIL 2 APPROVED TONE SELECTION

D1xS2FDC024-S/D1xS2HDC024-S sounders need to be set to one off the SIL 2 approved tones to work correctly with the automated sounder check on pattern generation and signal output checks.

Important: - Only tones use tones that are stated as SIL 2 approved for the SIL 2 application. Ensure that the unit is set to one of these tones see in Tone Table (D221-95-651-IS).

As factory default the sounder should be set to Stage 1 Dip SW1 to Tone 44 and Stage 2 Dip SW2 to Tone 1.

16-1) SIL 2 system wiring for fault detection in standby and active mode – 4 wire installation (Recommended)

The customer is required to wire into both the sounder power supply terminals block and also the SIL 2 Relay terminals TB1

The power supply terminals only need to have the supply power connected. This will be reverse polarity for monitoring mode and normal polarity for active mode. There is no need to fit an EOL resistor on the power supply terminal block as the TB1 is configured to raise a fault alarm in any situation.

Terminal block TB1 is the output from the SIL 2 monitoring relay. Relay RLY 1-2 provides a closed circuit between TB1 terminals 1 & 2 whilst powered. On detection of a fault event this will become open circuit.

The fault will be seen via the SIL 2 TB1 terminals as soon as the fault occurs in either Active or Standby modes.

When no fault is detected the circuit to the SIL 2 TB1 terminals 1 & 2 will include a factory fitted 3.3K Ohm current sense resistor (CSR) in series. When the circuit is driven with 24Vdc the detection current seen is ~7.3mA @ 24V.

The only other fault mode is if the cable goes short circuit where a short will be seen by the panel.

Option: Should the fault event output of RLY1-2 be required to operate as a switch, header J1 can be set to link pins 1 & 2 (see figure 11) thereby removing the 3.3k Ohm current sense resistor (CSR) from the circuit.

Note: a cable short circuit will not be detectable in this configuration.

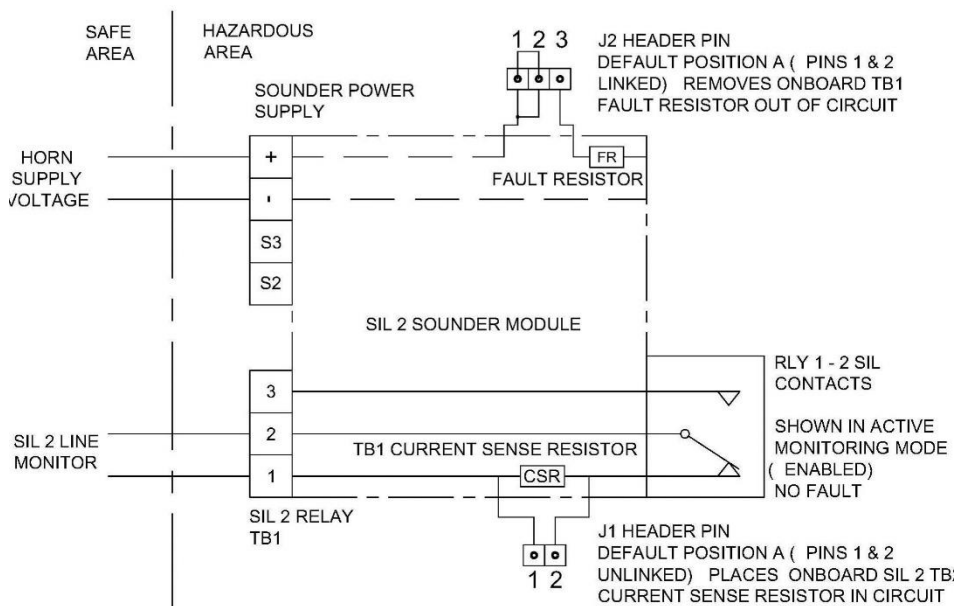

For one unit only:

Sounder power supply terminal block	Current drawn (mA)
Active Mode	190mA
Standby Mode	25mA

SIL2 TB1 Current Sense Resistor value	Current drawn (mA)
3.3kΩ	7.2mA

On fault mode, current drops to 0 as circuit goes open.

Figure 11 - Schematic of SIL 2 system wiring for fault detection in standby and active mode – 4 wire installation.

If multiple SIL 2 alarm horn sounders are to be cabled in series the monitoring connections differ from that of a single alarm horn sounder. For more information see manual D197-00-651-IS available from the E2S website.

16-2) SIL 2 system wiring for fault detection in standby mode only – 2 wire installation

Cabling is required to the positive '+' and negative '-' power input terminals only. Monitoring will occur in standby mode only whilst power supply polarity is reversed. An EOL resistor may be added during installation or can be factory fitted. See Table 5 for EOL resistor value guidance.

The SIL2 monitoring module contains a factory fitted Power Supply Fault Resistor 2.2K Ohm (FR). When a fault is detected the Fault Resistor will be activated. The total measurable resistance of the EOL resistor and Fault Resistor across the power terminals which already has customer EOL resistor (2.2kΩ) in place. This will result in a total fault detection current of 41.8mA @ 24V but can only be detected when unit is in Standby Mode.

Important: - The 2 wire configuration will not warn of a fault whilst in Active mode. A fault will only be detectable in standby mode when power supply polarity is reversed.

Important: - The 2-wire configuration requires the J2 header pin to be set to position B (see figure 14). Factory default position is A.

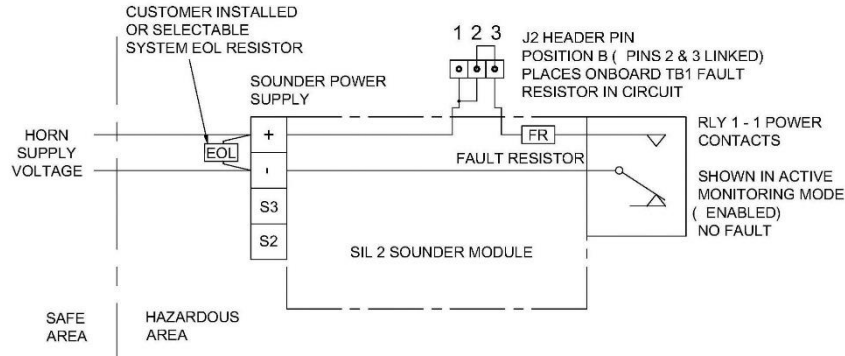

Figure 12 - Schematic of SIL 2 system wiring for fault detection in standby mode only – 2 wire installation

To evaluate the total current drawn from the SIL 2 unit, use the equation below.

$$I \text{ (Total Current drawn)} = I_{FR} \text{ (Current drawn from Fault Resistor)} + I_{EOL} \text{ (Current drawn from Customer EOL resistor)} + I_{SIL} \text{ (Current drawn from SIL board)}$$

In standby mode, where there is no fault, RLY 1-1 is open. This means the voltage only passes through the customer EOL resistor and the current drawn from the SIL 2 board is 25mA. Therefore, the equation for a No Fault scenario is then:

$$I_{NF} \text{ (Standby Mode, Total Current drawn - No Fault)} = I_{FR} \text{ (0mA)} + I_{EOL} \text{ (See table 5)} + I_{SIL} \text{ (25mA)}$$

In standby mode, where there is a fault, the circuit is closed. This means the voltage passes through both the customer EOL resistor and current sense resistor and the current drawn from the SIL 2 board is 20mA. The customer must first calculate the resistance of the two resistors in parallel before applying the currents to the equation. The equation for a Fault scenario is then:

$$I_F \text{ (Standby Mode, Total Current drawn - Fault)} = I_{TR} \text{ (Total Resistance when EOL & FR in parallel)} + I_{SIL} \text{ (20mA)}$$

Standby Mode	Power Supply Fault Resistor		Customer EOL Resistor		(Fault Mode Only)		Current drawn from SIL Board	Total current drawn
	Resistor Value	Current drawn (I_{FR})	Resistor Value	Current drawn (I_{EOL})	Total resistance	Current drawn (I_{TR})		
No Fault	2.2 kΩ	0 mA	2.2 kΩ	10.9 mA	-	-	25 mA	35.9 mA
Fault		-		-	1.1 kΩ	21.8 mA	20 mA	41.8 mA
No Fault	1.0 kΩ	0 mA	1.0 kΩ	24.0 mA	-	-	25 mA	49.0 mA
Fault		-		-	500 Ω	48.0 mA	20 mA	68.0 mA
No Fault	2.2 kΩ	0 mA	3.3 kΩ	7.3 mA	-	-	25 mA	32.3 mA
Fault		-		-	1.3 kΩ	18.2 mA	20 mA	38.2 mA
No Fault	1.8 kΩ	0 mA	3.9 kΩ	6.2 mA	-	-	25 mA	31.2 mA
Fault		-		-	1.2 kΩ	19.5 mA	20 mA	39.5 mA
No Fault	1.8 kΩ	0 mA	4.7 kΩ	5.1 mA	-	-	25 mA	30.1 mA
Fault		-		-	1.3 kΩ	18.4 mA	20 mA	38.4 mA
No Fault	2.2 kΩ	0 mA	4.7 kΩ	5.1 mA	-	-	25 mA	30.1 mA
Fault		-		-	1.5 kΩ	16.0 mA	20 mA	36.0 mA

Table 5: Resistor combinations and the currents drawn when no faults and faults occur

If multiple SIL 2 alarm horn sounders are to be cabled in series the monitoring connections differ from that of a single alarm horn sounder. For more information see manual D197-00-651-IS available from the E2S website.

16-3 Header Pins Settings

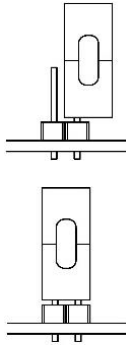
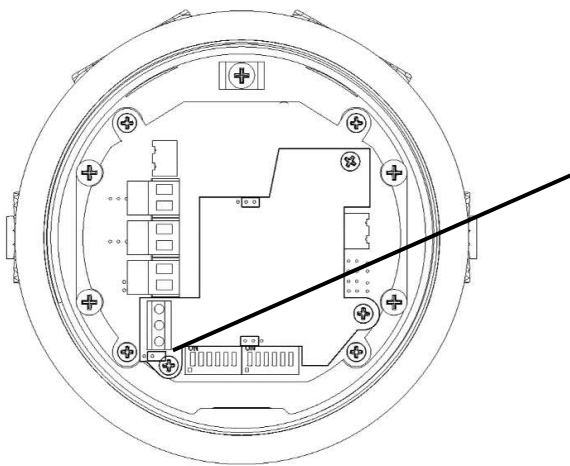

J1 Header Pin - Position A
 Factory default position (pins 1 & 2 not linked)
 Places TB1 Current Sense Resistor (CSR) in circuit.
 As used in 4 - Wire Configuration

J1 Header Pin - Position B
 (pins 1 & 2 linked)
 Removes TB1 Current Sense Resistor (CSR) out of circuit.

Figure 13: J1 Header pin positions – Current Sense Resistor (CSR)

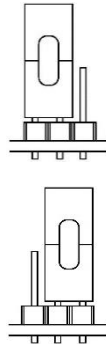
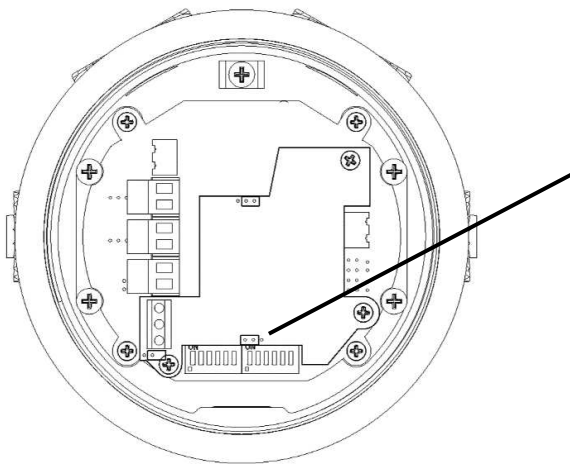

J2 Header Pin - Position A
 Factory default position (pins 1 & 2 linked)
 Removes power supply terminal Fault Resistor (FR) & RLY 1-2 out of circuit.
 As used in 4 -Wire Configuration

J2 Header Pin - Position B
 (pins 2 & 3 linked)
 Places power supply terminal Fault resistor & RLY 1-2 in circuit.
 As used in 2 – Wire Configuration

Figure 14: J2 Header pin positions – Fault Resistor (FR)

16-4 SIL 2 Hard Reset Function

Power down the unit completely for a minimum of 30 seconds. Move the hard reset header pin (Jumper J3) to reset position B shown. Then power the unit for a minimum of 5 seconds. Power down the unit for 30 seconds and then move the header pin back to Position A.

The unit has now been reset.

If the hard reset process does not correct the latched fault the alarm horn sounder may require further investigation, please contact your local E2S representative.

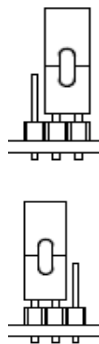
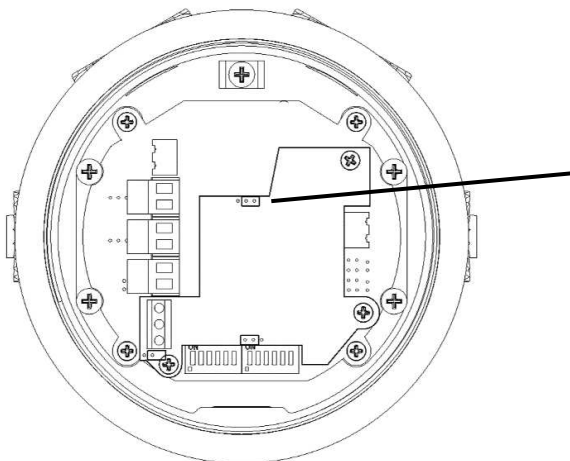

J3 Header Pin - Position A
 Factory default position (pins 2 & 3 linked)
 Hard Reset Function disabled – Normal Operation

J3 Header Pin - Position B
 (pins 1 & 2 linked)
 Hard Reset Enabled - Active reset mode

Figure 15: J3 Header pin positions – Hard Reset Function

17) SIL 2 Specific Unit Mounting Requirements

The sounder should be mounted no closer than 5m from a sounder source of similar SPL output. This is to ensure false tone activation does not occur when the unit is monitoring the tone pulse duration and tone failure.

18) SIL 2 Reliability Data

Reliability and Functional safety IEC/EN61508 which has been assessed and is considered suitable for use in low demand safety function:

1. Random Hardware Failures and Architectural constraints (route 1_H)
2. As an unvoted item (i.e. hardware fault tolerance of 0) at SIL 2

The product was assessed against failure modes:

- Failure respond to an input with a correct tone.
- Failure to respond to an input even with an alternative tone.
- Spurious sound output despite no input.

D1xS2FDC024-S/D1xS2HDC024-S (Failure to Sound)

Integrity in respect of failure to release	SIL 2
Total Failure rate	0.447 pmh
"hazardous" failure rate (revealed)	0.443 pmh
"hazardous" failure rate (unrevealed)	0.004 pmh
"safe" failure rate (revealed)	0.002 pmh
"safe" failure rate (unrevealed)	0
Diagnostic Coverage	99%
System type	B
Hardware Fault Tolerance	0
Safe Failure Fraction	>99%
PFDD (hazardous failure)	3.3×10^{-5}
Proof Test Interval	Up to 1 year

D1xS2FDC024-S/D1xS2HDC024-S (Failure to Sound or Incorrect tone)

Integrity in respect of failure to release	SIL 2
Total Failure rate	0.464 pmh
"hazardous" failure rate (revealed)	0.455 pmh
"hazardous" failure rate (unrevealed)	0.009pmh
"safe" failure rate (revealed)	0.002 pmh
"safe" failure rate (unrevealed)	0
Diagnostic Coverage	98%
System type	B
Hardware Fault Tolerance	0
Safe Failure Fraction	>97%
PFDD (hazardous failure)	5.2×10^{-5}
Proof Test Interval	Up to 1 year

Table 6: SIL 2 Failure Rate

19) Synchronised Operation

All D1xS2FDC024-S/D1xS2HDC024-S alarm horn sounders connected to the same power supply and set to the same alarm tone will provide a synchronised output when activated.

20) Product Coding for Fault Resistor and Customer EOL Resistor

The customer is able to identify the resistor values chosen on purchase from the product code.
This is represented by the last three characters:

D1xS2FDC024AB1S1R-**AFZ**

- The first A character denotes the value of the Fault Resistor (FR) Default value is 2.2 kΩ (Code = A) unless an alternative value is requested when ordering.
- The second F character denotes the value of the Current Sense Resistor (CSR) Default value is 3.3 kΩ (Code = F) unless an alternative value is requested when ordering.
- The third Z character denotes the value of the unit End Of Line Resistor (EOL) By default no EOL is fitted (Code = Z) A factory fitted EOL resistor can be specified when ordering.

The values of resistors available are shown in table 7 below.

Code	Resistor Value
A	2.2 kΩ
B	1.0 kΩ
C	1.5 kΩ
D	1.8 kΩ
E	2.7 kΩ
F	3.3 kΩ
G	3.9 kΩ
H	4.7 kΩ
J	5.6 kΩ
K	6.8 kΩ
L	8.2 kΩ
M	11 kΩ
Z	None Fitted

Table 7: Resistor Value code

Default resistor coding as follows.

D1xS2FDC024AB1S1R-**AFZ**

Example of a custom requirement resistor coding:

D1xS2FDC024AB1S1R-**GEF**

Where the (FR) Fault Resistor is (G = 3.9 kΩ)
(CSR) Current Sense Resistor is (E = 2.7 kΩ)
(EOL) End Of Line resistor is (F = 3.3 kΩ)

Note: To utilise the full monitoring functionality the 4-wire configuration is recommended. An EOL resistor is not required for this configuration.

The alternative 2-wire configuration requires an EOL resistor to be fitted. The EOL resistor can be specified during ordering and factory fitted or selected and fitted during the alarm horn sounder installation.

See section 9 for EOL resistor location and wattage requirements. E2S recommends a value of 2.2K Ohm. If an alternative value is required, please see section 16-2.

Both the (FR) Fault Resistor and (CSR) Current Sense Resistor are factory fitted and cannot be user replaced.

Product Option 'S' SIL 2 Approved Tone Table

Stage 1 Set DIP SW 1 Tone No.	SIL 2 Approved Tone.	Tone Description	Tone Visual	Stage 1 DIP SW 1/2 Settings 1 2 3 4 5 6	Stage 3 Set DIP SW 1 (S3)	Stage 4 Set DIP SW 1 (S2 + S3)	
1	Yes	1000Hz PFEER Toxic Gas		0 0 0 0 0	2	44	
2	Yes	1200/500Hz @ 1Hz DIN /PFEER P.T.A.P.		1 0 0 0 0	3	44	
3	Yes	1000Hz @ 0.5Hz(1s on, 1soff) PFEER Gen. Alarm		0 1 0 0 0	2	44	
4	Yes	1.4KHz-1.6KHz 1s, 1.6KHz-1.4KHz 0.5s NF C 48-265		1 1 0 0 0	24	1	
5	Yes	544Hz(100mS)/440Hz (400mS) NF S 32-001		0 0 1 0 0	19	1	
6	Yes	1500/500Hz - (0.5s on , 0.5s off) x3 + 1s gap AS4428		1 0 1 0 0	44	1	
7	Yes	500-1500Hz Sweeping 2 sec on 1 sec off AS4428		0 1 1 0 0	44	1	
8	Yes	500/1200Hz @ 0.26Hz (3.3son, 0.5s off) Netherlands - NEN 2575		1 1 1 0 0	24	35	
9	Yes	1000Hz (1s on, 1s off)x7 + (7s on, 1s off) IMO Code 1a		0 0 0 1 0	34	1	
10	Yes	1000Hz (1s on, 1s off)x7 + (7s on, 1s off) IMO Code 1a		1 0 0 1 0	34	1	
11	Yes	420Hz(0.5s on, 0.5s off)x3 + 1s gap ISO 8201 Temporal Pattern		0 1 0 1 0	1	8	
12	Yes	1000Hz(0.5s on, 0.5s off)x3 + 1s gap ISO 8201 Temporal Pattern		1 1 0 1 0	1	8	
13	Yes	422/775Hz - (0.85 on, 0.5 off) x3 + 1s gap NFPA - Temporal Codod		0 0 1 1 0	1	8	
14	Yes	1000/2000Hz @ 1Hz Alternating Singapore		1 0 1 1 0	3	35	
15	Yes	300Hz Continuous (f=300)		0 1 1 1 0	24	1	
16	Yes	440Hz Continuous (f=440)		1 1 1 1 0	24	1	
17	Yes	470Hz Continuous (f=470)		0 0 0 1 0	24	8	
18	Yes	500Hz Continuous IMO code 2 (Low) (f=500)		1 0 0 1 0	24	8	
19	Yes	554Hz Continuous (f=554)		0 1 0 1 0	24	8	
20	Yes	660Hz Continuous (f=660)		1 1 0 1 0	24	35	
21	Yes	800Hz IMO code 2 (High) (f=800)		0 0 1 0 1	24	35	
22	Yes	1200Hz Continuous (f=1200)		1 0 1 0 1	24	35	
23	Yes	2000Hz Continuous (f=2000)		0 1 1 0 1	3	35	
24	Yes	2400Hz Continuous (f=2400)		1 1 1 0 1	20	35	
25	Yes	440Hz @0.83Hz (50 cycles/minute) Intermittent (f=440, a=0.6, b=0.6)		0 0 0 1 1	44	8	
26	Yes	470Hz @0.9Hz - 1.1s Intermittent (f=470, a=0.55, b=0.55)		1 0 0 1 1	44	8	
27	No	470Hz @5Hz - (5 cycles/second) Intermittent (f=470, a=0.1, b=0.1)		0 1 0 1 1	44	8	
28	Yes	544Hz @ 1.14Hz - 0.875s Intermittent (f=470, a=0.43, b=0.44)		1 1 0 1 1	24	8	
29	Yes	655Hz @ 0.875Hz Intermittent (f=655, a=0.57, b=0.57)		0 0 1 1 1	24	8	
30	Yes	660Hz @0.28Hz - 1.8sec on, 1.8sec off Intermittent (f=660, a=1.8, b=1.8)		1 0 1 1 1	24	8	
31	No	660Hz @3.34Hz - 150mS on, 150mS off Intermittent (f=660, a=0.15, b=0.15)		0 1 1 1 1	24	8	
32	Yes	745Hz @ 1Hz Intermittent (f=745, a=0.5, b=0.5)		1 1 1 1 1	24	8	
33	Yes	800Hz - 0.25sec on, 1 sec off Intermittent (f=800, a=0.25, b=1)		0 0 0 0 1	24	8	
34	Yes	800Hz @ 2Hz IMO code 3.a (High) Intermittent (f=800, a=0.25, b=0.25)		1 0 0 0 1	24	19	
35	Yes	1000Hz @ 1Hz Intermittent (f=1000, a=0.5, b=0.5)	0 1 0 0 1	24	19		
36	Yes	2400Hz @ 1Hz Intermittent (f=2400, a=0.5, b=0.5)	1 1 0 0 1	24	19		
37	No	2900Hz @ 5Hz Intermittent (f=2900, a=0.1, b=0.1)	0 0 1 0 1	24	19		
38	Yes	363/518Hz @ 1Hz Alternating (f=363, f1=518, a=0.1)		1 0 1 0 1	8	19	
39	Yes	450/500Hz @ 2Hz Alternating (f=450, f1=500, a=0.25)		0 1 1 0 1	8	19	
40	Yes	554/440Hz @ 1Hz Alternating (f=440, f1=554, a=0.5)		1 1 1 0 1	24	19	
41	Yes	554/440Hz @ 0.625Hz Alternating (f=440, f1=554, a=0.8)		0 0 0 1 1	8	19	
42	Yes	561/760Hz @0.83Hz (50 cycles/minute) Alternating (f=561, f1=760, a=0.6)		1 0 0 1 1	8	19	
43	Yes	780/600Hz @ 0.96Hz Alternating (f=600, f1=780, a=0.52)			0 1 0 1 1	8	19
44	Yes	800/1000Hz @ 2Hz Alternating (f=800, f1=1000, a=0.25)			1 1 0 1 1	24	19
45	Yes	970/800Hz @ 2Hz Alternating (f=800, f1=970, a=0.25)			0 0 1 1 1	8	19
46	Yes	800/1000Hz @ 0.875Hz Alternating (f=800, f1=1000, a=0.57)			1 0 1 1 1	24	19
47	Yes	2400/2900Hz @ 2Hz Alternating (f=2400, f1=2900, a=0.25)			0 1 1 1 1	24	19
48	Yes	500/1200Hz @ 0.3Hz Sweeping (f=500, f1=1200, a=3.34)		1 1 1 1 1	24	12	
49	Yes	560/1055Hz @ 0.18Hz Sweeping (f=560, f1=1055, a=5.47)		0 0 0 1 1	24	12	
50	No	560/1055Hz @ 3.3Hz Sweeping (f=560, f1=1055, a=0.3)		1 0 0 0 1	24	12	
51	Yes	600/1250Hz @ 0.125Hz Sweeping (f=600, f1=1250, a=8)			0 1 0 0 1	24	12
52	Yes	660/1200Hz @ 1Hz Sweeping (f=660, f1=1200, a=1)		1 1 0 0 1	24	12	
53	Yes	800/1000Hz @ 1Hz Sweeping (f=800, f1=1000, a=1)		0 0 1 0 1	24	12	
54	No	800/1000Hz @ 7Hz Sweeping (f=800, f1=1000, a=0.14)		1 0 1 0 1	24	12	
55	No	800/1000Hz @ 50Hz Sweeping (f=800, f1=1000, a=0.02)		0 1 1 0 1	24	12	
56	No	2400/2900Hz @ 7Hz Sweeping (f=2400, f1=2900, a=0.14)		1 1 1 0 1	24	12	
57	Yes	2400/2900Hz @ 1Hz Sweeping (f=2400, f1=2900, a=1)		0 0 0 1 1	24	12	
58	No	2400/2900Hz @ 50Hz Sweeping (f=2400, f1=2900, a=0.02)	1 0 0 1 1	24	12		
59	Yes	2500/3000Hz @ 2Hz Sweeping (f=2500, f1=3000, a=0.5)	0 1 0 1 1	24	12		
60	No	2500/3000Hz @ 7.7Hz Sweeping (f=2500, f1=3000, a=0.13)	1 1 0 1 1	24	12		
61	No	800Hz Motor Siren (f=800, a=1.8)		0 0 1 1 1	24	12	
62	No	1200Hz Motor Siren (f=1200, a=2)		1 0 1 1 1	24	12	
63	No	2400Hz Motor Siren (f=2400, a=1.7)		0 1 1 1 1	24	12	
64	No	Simulated Bell			1 1 1 1 1	21	12

1	2	3	4	5	6	7	8	9	10
							ISSUE	MOD No.	REASON - INITIAL - DATE
							1		INTRODUCTION RSR - 19/09/2022

OPTIONAL LINE MONITORING RESISTOR, CUSTOMER SUPPLIED,
RECOMMENDED VALUE FOR SIL 2 EOL = 2.2KΩ 2.0W
MINIMUM EOL RESISTOR VALUES FOR 28VDC MAX VOLTAGE
500Ω MIN AT 2W MIN OR 2.4KΩ MIN AT 0.5W MIN



Single Stage Configuration Line Monitoring Set to positive switching (default)	Config.: 1a	Two Stage Configuration Common Negative Set to positive switching (default)	Config.: 1b	Three/Four Stage Configuration Common Negative Set to positive switching (default)	Config.: 1c
Stage 1: Apply Power to Stage 1 +ve & Stage 1 -ve For full 4-Wire SIL 2 Connection Monitor SIL 2 +ve and SIL 2 -ve Terminals 1 & 2 in RLY1-2		Stage 1: Apply Power to Stage 1 +ve & Common -ve Stage 2: Apply Power to Stage 2 +ve & Common -ve For full 4-Wire SIL 2 Connection Monitor SIL 2 +ve and SIL 2 -ve Terminals 1 & 2 in RLY1-2		Stage 1: Apply Power to Stage 1 +ve & Common -ve Stage 2: Apply Power to Stage 2 +ve & Common -ve Stage 3: Apply Power to Stage 3 +ve & Common -ve Stage 4: Apply Power to Stage 2 +ve, Stage 3 +ve & Common -ve For full 4-Wire SIL 2 Connection Monitor SIL 2 +ve and SIL 2 -ve Terminals 1 & 2 in RLY1-2	

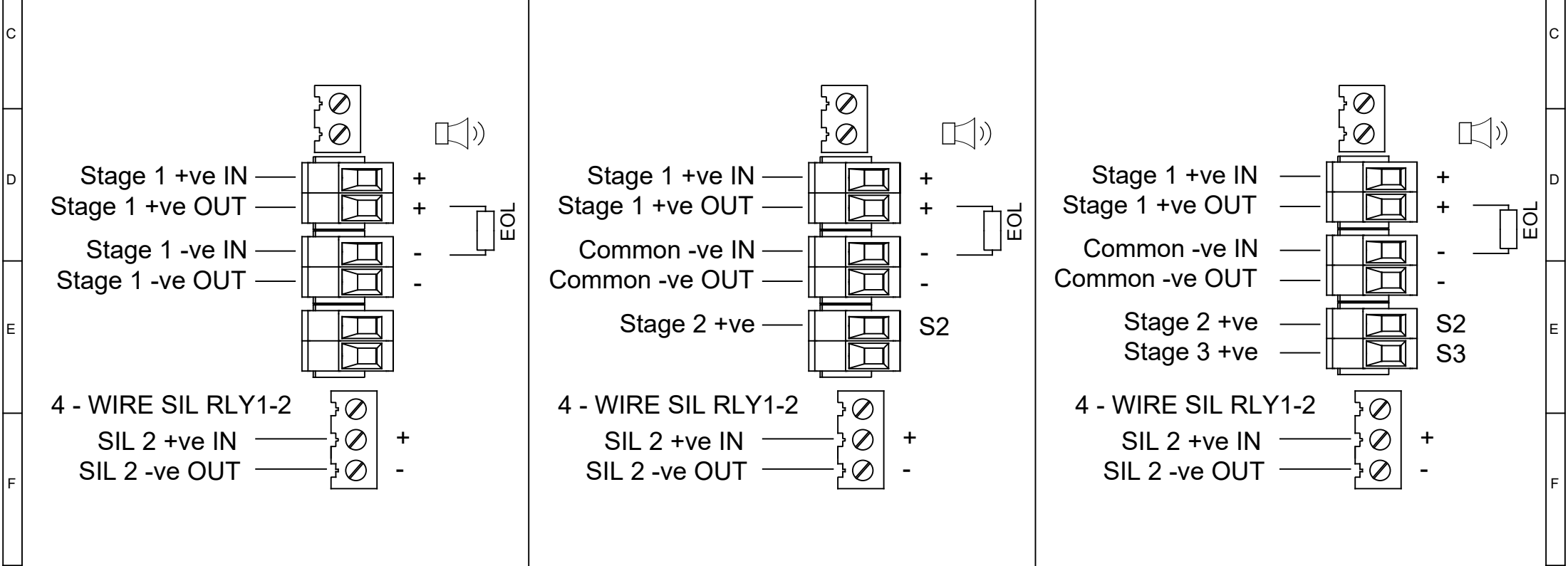

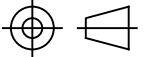
DRAWING TO BS8888:2000 GEOMETRIC TOLERANCES TO ISO1101:1983 LINEAR DIMENSIONAL TOLS ANGULAR DIMENSIONAL TOLS	DRAWN R.S.RAIT	DATE 19/09/2022	SURFACE FINISH	WEIGHT (Kg)	THIS DRAWING AND ANY INFORMATION OR DESCRIPTIVE MATTER THEREIN IS COMMUNICATED IN CONFIDENCE AND IS THE COPYRIGHT PROPERTY OF EUROPEAN SAFETY SYSTEMS LTD. NEITHER THE WHOLE OR ANY EXTRACT MAY BE DISCLOSED, LOANED, COPIED OR USED FOR MANUFACTURING OR TENDERING PURPOSES WITHOUT THEIR WRITTEN CONSENT. © EUROPEAN SAFETY SYSTEMS LTD. AS PER LATEST DATE OF ISSUE SHOWN ABOVE	 EUROPEAN SAFETY SYSTEMS LTD IMPRESS HOUSE MANSELL ROAD ACTON LONDON W3 7QH WWW.E2S.COM	ALL DIMENSIONS IN MM IF IN DOUBT, ASK - DO NOT SCALE		A3
	CHECKED B.ISARD	DATE 19/09/2022	MATERIAL	TITLE D1xS1 / D1xS2 / GNExS1 / GNExS2 / STExS1 / STExS2 SIL 2 DC SOUNDER WIRING DIAGRAMS					
	STANDARDS D1x	APPROVED R.N.POTTS	DATE 19/09/2022	ALTERNATIVE MATERIAL			SCALE NTS	SHEET 1 OF 2	DRAWING NUMBER D190-06-651

ISSUE	MOD No.	REASON - INITIAL - DATE
1		INTRODUCTION RSR - 19/09/2022

OPTIONAL LINE MONITORING RESISTOR, CUSTOMER SUPPLIED,
RECOMMENDED VALUE FOR SIL 2 EOL = 2.2KΩ 2.0W
MINIMUM EOL RESISTOR VALUES FOR 28VDC MAX VOLTAGE
500Ω MIN AT 2W MIN OR 2.4KΩ MIN AT 0.5W MIN

SWITCHES FOR STAGE OPERATION
CUSTOMER SUPPLIED

Three/Four Stages. Voltage Free 2nd, 3rd & 4th Stage Activation Configuration Config.: 2

Common Positive
Customer Set H1 & H2 to Negative Switching (See Below)

Stage 1: Apply Power to Common +ve & Stage 1 -ve
Stage 2: Apply Power to Common +ve & Stage 1 -ve & connect Stage 2 -ve to Stage 1 -ve
Stage 3: Apply Power to Common +ve & Stage 1 -ve & connect Stage 3 -ve to Stage 1 -ve
Stage 4: Apply Power to Common +ve & Stage 1 -ve

& connect Stage 2 -ve & Stage 3 -ve to Stage 1 -ve
For full 4-Wire SIL 2 Connection Monitor SIL 2 +ve and SIL 2 -ve Terminals 1 & 2 in RLY1-2

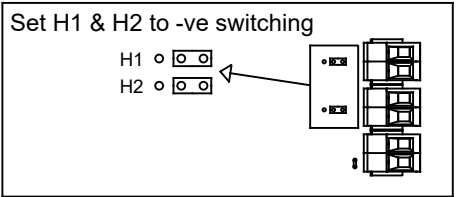
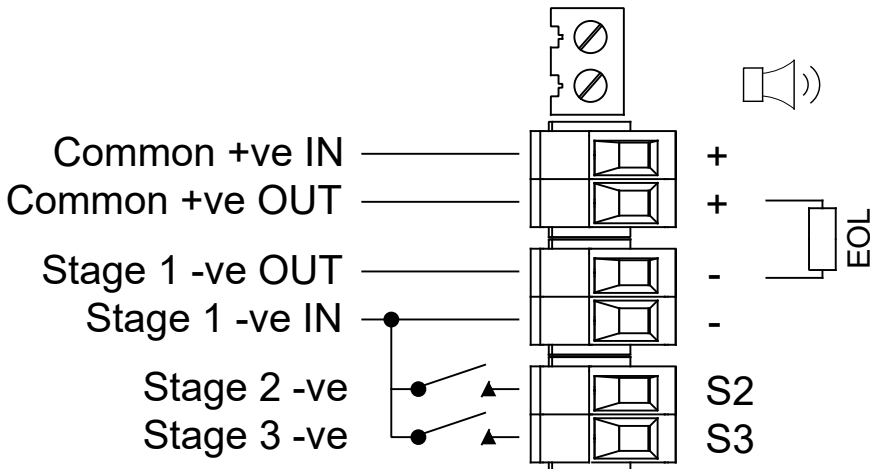

STANDARDS	DRAWN	DATE	SURFACE FINISH	WEIGHT (Kg)
	R.S.RAIT	19/09/2022	MATERIAL	
	CHECKED	DATE	ALTERNATIVE MATERIAL	
	B.ISARD	19/09/2022		
	APPROVED	DATE		
D1x	R.N.POTTS	19/09/2022		

DRAWING TO BS8888:2000 GEOMETRIC TOLERANCES TO ISO1101:1983 LINEAR DIMENSIONAL TOLS ANGULAR DIMENSIONAL TOLS				
---	--	--	--	--

THIS DRAWING AND ANY INFORMATION OR DESCRIPTIVE MATTER THEREIN IS COMMUNICATED IN CONFIDENCE AND IS THE COPYRIGHT PROPERTY OF EUROPEAN SAFETY SYSTEMS LTD. NEITHER THE WHOLE OR ANY EXTRACT MAY BE DISCLOSED, LOANED, COPIED OR USED FOR MANUFACTURING OR TENDERING PURPOSES WITHOUT THEIR WRITTEN CONSENT.

© EUROPEAN SAFETY SYSTEMS LTD.
AS PER LATEST DATE OF ISSUE SHOWN ABOVE

EUROPEAN SAFETY SYSTEMS LTD
IMPRESS HOUSE
MANSELL ROAD
ACTON
LONDON W3 7QH
WWW.E2S.COM

ALL DIMENSIONS IN MM IF IN DOUBT, ASK - DO NOT SCALE			A3
TITLE D1xS1 / D1xS2 / GNExS1 / GNExS2 / STExS1 / STExS2 SIL 2 DC SOUNDER WIRING DIAGRAMS			
SCALE	SHEET	DRAWING NUMBER	
NTS	2 OF 2	D190-06-651	

EU Declaration of Conformity



Manufacturer: European Safety Systems Ltd.
Impress House, Mansell Road, Acton
London, W3 7QH
United Kingdom

Authorised Representative: E2S Warnsignaltechnik UG
Charlottenstrasse 45-51
72764 Reutlingen
Germany

Equipment Type: D1xS1, D1xS2
D1xL1, D1xL2
D1xC1X05, D1xC1X10, D1xC2X05, D1xC2X10
D1xB2XH1, D1xB2XH2

Directive 2014/34/EU: Equipment and Protective Systems for use in Potentially Explosive Atmospheres (ATEX) - D1xS1, D1xS2, D1xL1, D1xL2, D1xC1X05, D1xC1X10, D1xC2X05 and D1xC2X10 only

Notified Body for EU type Examination (Module B):	UL International Demko A/S Borupvang 5A 2750 Ballerup Denmark
EU-type Examination Certificate (Module B):	DEMKO 19 ATEX 2141X
Notified Body for Quality Assurance Notification / Conformity to EU-type based on quality assurance of the production process (Module D):	Sira Certification Service Notified Body No.: 2813 Unit 6, Hawarden Industrial Park, Hawarden, Deeside, CH5 3US, UK
Quality Assurance Notification (Module D):	SIRA 05 ATEX M342
Provisions fulfilled by the equipment:	II 2G Ex db IIC T6...T3 GB II 2D Ex tb IIIC T82°C...145°C Db
Standards applied:	EN 60079-0:2018 EN 60079-1:2014 EN60079-31:2014

Directive 2014/30/EU: Electromagnetic Compatibility Directive (EMC)

Standards applied:	EN 61000-6-1:2007 EN 61000-6-2:2005 EN 61000-6-3:2007 / A1:2011 / AC: 2012 EN 61000-6-4:2007 / A1: 2011
--------------------	--

Directive 2014/35/EU: Low Voltage Directive (LVD)

Standards applied:	EN 60947-1:2007 + A2:2014
--------------------	---------------------------

Directive 2011/65/EU: Restriction of the use of certain hazardous substances in electrical and electronic equipment (RoHS)

The product and all the components contained within it are in accordance with the restriction of the use of hazardous substances in electrical and electronic equipment, including amendment by Directive 2015/863/EU.

Regulation (EC) 1907/2006: Registration, Evaluation, Authorisation and Restriction of Chemicals (REACH)

The product and all the components contained within it are free from substances of very high concern.

Other Standards and Regulations

EN 60529:1992+A2:2013 - Degrees of protection provided by enclosures (IP code) – enclosure rated IP66

EU Declaration of Conformity



On behalf of European Safety Systems Ltd., I declare that, on the date the equipment accompanied by this declaration is placed on the market, the equipment conforms with all technical and regulatory requirements of the above listed directives, regulations and standards.

This Declaration is issued under the sole responsibility of the manufacturer.

A handwritten signature in black ink, appearing to read 'Martin Streetz'.

Martin Streetz
Quality Assurance Manager

Document No.: DC-067_Issue_H
Date and Place of Issue: London, 10/02/2022



UKCA Declaration of Conformity



Manufacturer: European Safety Systems Ltd.
Impress House, Mansell Road, Acton
London, W3 7QH
United Kingdom

Equipment Type: D1xS1, D1xS2
D1xL1, D1xL2
D1xC1X05, D1xC1X10, D1xC2X05, D1xC2X10

Directive UKSI 2016:1107 (as amended by UKSI 2019:696) – Schedule 3A, Part 1 : Product or Protective System Intended for use in Potentially Explosive Atmospheres (UKCA)

Notified Body for UK type Examination (Module B):	UL International (UK) Ltd Notified Body No.: 0843 Unit 1-3 Horizon Kingsland Business Park, Wade Road, Basingstoke, Hampshire RG24 8AH UK
UK-type Examination Certificate (Module B):	UL21UKEX2132X
Notified Body for Quality Assurance Notification / Conformity to EU-type based on quality assurance of the production process (Module D):	Sira Certification Service Notified Body No.: 0518 Rake Lane, Eccleston, Chester CH4 9JN, UK
Quality Assurance Notification (Module D):	CSAE 22UKQAN0046
Provisions fulfilled by the equipment:	II 2G Ex db IIC T6...T3 GB II 2D Ex tb IIIC T82°C...145°C Db
Standards applied:	EN 60079-0:2018 EN 60079-1:2014 EN60079-31:2014

Directive 2014/30/EU: Electromagnetic Compatibility Directive (EMC)

Standards applied:	EN 61000-6-1:2007 EN 61000-6-2:2005 EN 61000-6-3:2007 / A1:2011 / AC: 2012 EN 61000-6-4:2007 / A1: 2011
--------------------	--

Directive 2014/35/EU: Low Voltage Directive (LVD)

Standards applied:	EN 60947-1:2007 + A2:2014
--------------------	---------------------------

Directive 2011/65/EU: Restriction of the use of certain hazardous substances in electrical and electronic equipment (RoHS)

The product and all the components contained within it are in accordance with the restriction of the use of hazardous substances in electrical and electronic equipment, including amendment by Directive 2015/863/EU.

Regulation (EC) 1907/2006: Registration, Evaluation, Authorisation and Restriction of Chemicals (REACH)

The product and all the components contained within it are free from substances of very high concern.

Other Standards and Regulations

EN 60529:1992+A2:2013 - Degrees of protection provided by enclosures (IP code) – enclosure rated IP66

UKCA Declaration of Conformity



On behalf of European Safety Systems Ltd., I declare that, on the date the equipment accompanied by this declaration is placed on the market, the equipment conforms with all technical and regulatory requirements of the above listed directives, regulations and standards.

This Declaration is issued under the sole responsibility of the manufacturer.

A handwritten signature in black ink, appearing to read 'Martin Streetz'.

Martin Streetz
Quality Assurance Manager

Document No.: DC-097_Issue_A
Date and Place of Issue: London, 24/02/2022