

DC CONFIGURATIONS

E2S PART NO
D1x[C3][N2][XX][XX][XXX]

Note: Alternative wiring configurations may be available on request - contact E2S sales

DESCRIPTION
D1xC3 STACK
2 BEACONS & ALARM HORN

DATA REFERENCE
1-26-080

ISSUE	MOD No.	REASON - INITIAL - DATE
2		TB 8 TERMINALS WAS 6 : BEACON 1 CONNECTED TO TB. DAH - 24-02-2020
3		DC WAS -VE STAGE SWITCHING NOW +VE. SOUNDER TNALS UPDATED TO NEW PCBA. DAH - 22-09-2020
4		CONFIG 1-6 ADDED. SH2, 3 ADDED DAH - 20-04-2023

CONFIG. 1 (DEFAULT)

DC VOLTAGE SUPPLY
COMMON NEGATIVE CONNECTION TO ALL SIGNALS
POSITIVE STAGE SWITCHING FOR ALARM HORN SOUNDER

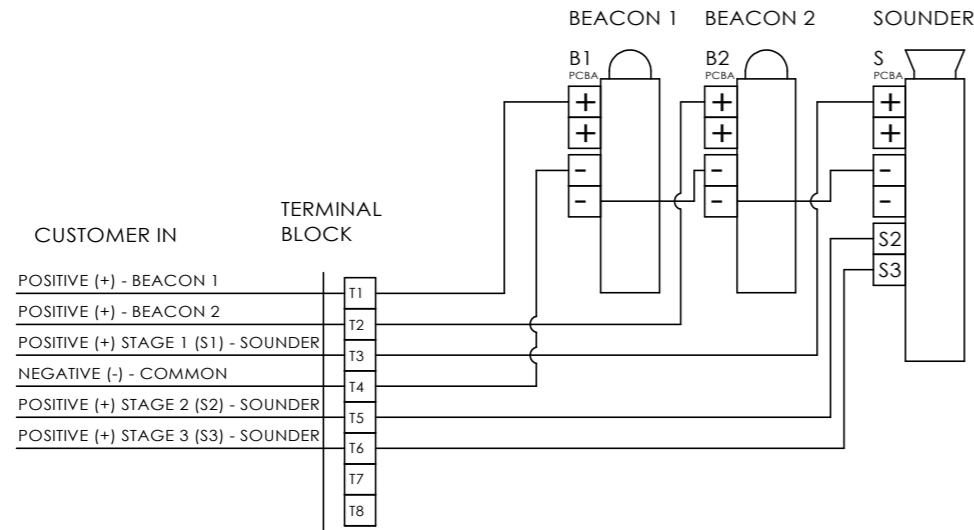

CONFIG. 3

DC VOLTAGE SUPPLY
COMMON NEGATIVE CONNECTION TO ALL SIGNALS
NEGATIVE STAGE SWITCHING FOR ALARM HORN SOUNDER

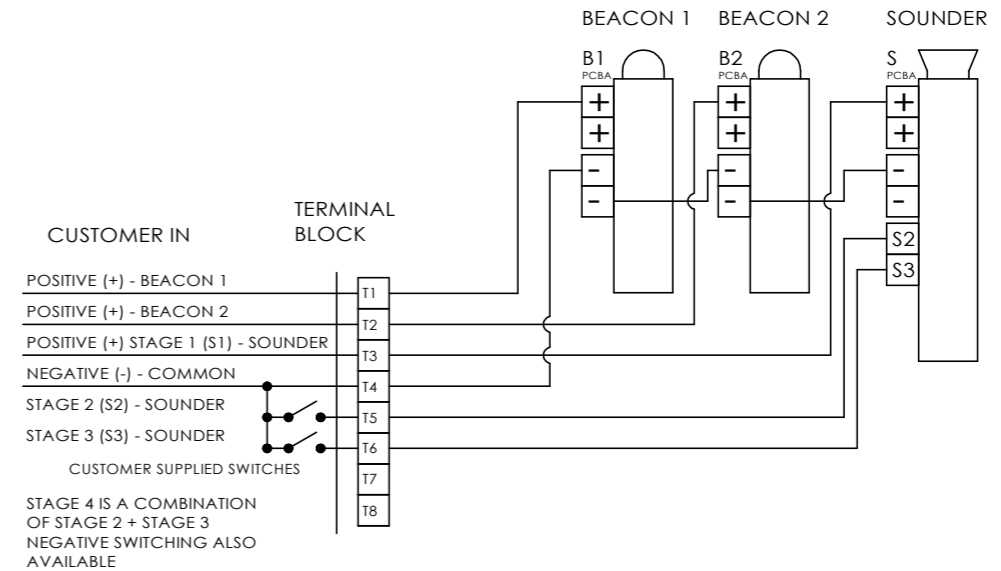

CONFIG. 2

DC VOLTAGE SUPPLY
INDEPENDENT CONNECTIONS TO ALL SIGNALS
POSITIVE STAGE SWITCHING FOR ALARM HORN SOUNDER

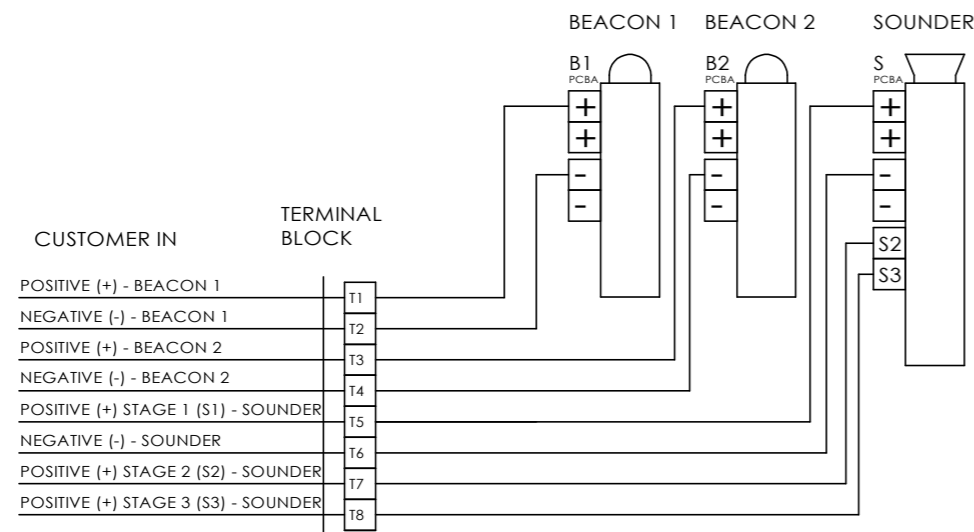

CONFIG. 4

DC VOLTAGE SUPPLY
INDEPENDENT CONNECTIONS TO ALL SIGNALS
NEGATIVE STAGE SWITCHING FOR ALARM HORN SOUNDER

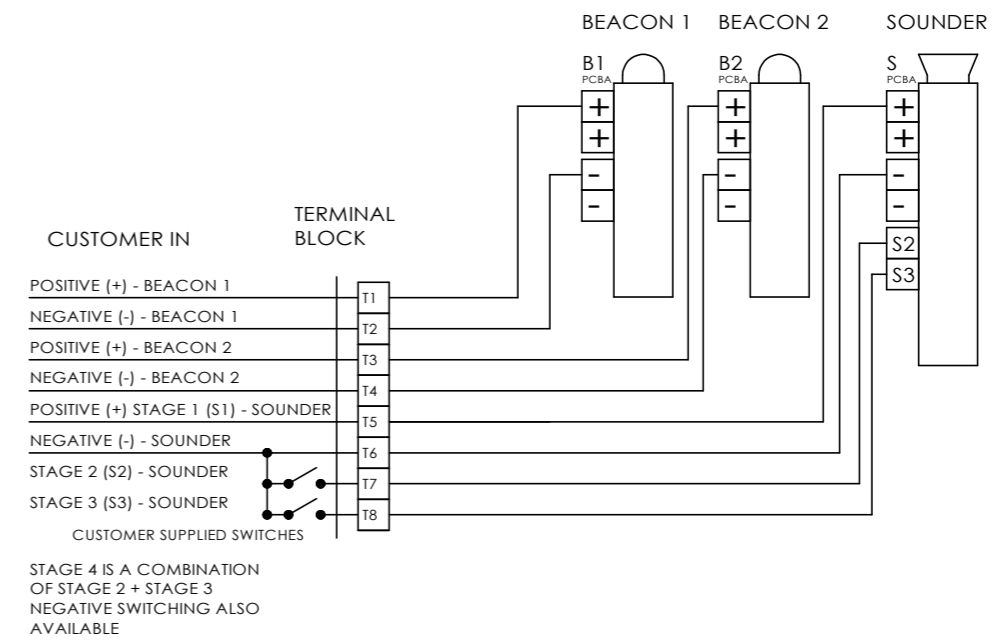

DRAWING TO BS8888:2000
GEOMETRIC TOLERANCES TO ISO1101:1983
LINEAR DIMENSIONAL TOLS
ANGULAR DIMENSIONAL TOLS

DRAWN	DATE
D.HOWGILL	15-08-2019
CHECKED	DATE
R.N.POTTS	15-08-2019
APPROVED	DATE
R.N.POTTS	15-08-2019

SURFACE FINISH	WEIGHT (kg)
FINISH	
MATERIAL	
ALTERNATIVE MATERIAL	

THIS DRAWING AND ANY INFORMATION OR DESCRIPTIVE MATTER THEREIN IS COMMUNICATED IN CONFIDENCE AND IS THE COPYRIGHT PROPERTY OF EUROPEAN SAFETY SYSTEMS LTD. NEITHER THE WHOLE OR ANY EXTRACT MAY BE DISCLOSED, LOANED, COPIED OR USED FOR MANUFACTURING OR TENDERING PURPOSES WITHOUT THEIR WRITTEN CONSENT.

EUROPEAN SAFETY SYSTEMS LTD.
AS PER LATEST DATE OF ISSUE SHOWN ABOVE

e2s
warning signals
EUROPEAN SAFETY SYSTEMS LTD
IMPRESS HOUSE
MANSELL ROAD
ACTON
LONDON W3 7QH
WWW.E2S.COM

ALL DIMENSIONS IN MM
IF IN DOUBT, ASK -
DO NOT SCALE

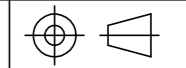

A2

TITLE D1xC3 STACK - 2 BEACONS & ALARM HORN WIRING SCHEMATIC

SCALE	SHEET	DRAWING NUMBER
NTS	1 OF 3	D226-06-135

DC CONFIGURATIONS

ISSUE	MOD No.	REASON - INITIAL - DATE
2		SEE SH1
3		SEE SH1
4		SEE SH1

CONFIG. 5

DC VOLTAGE SUPPLY
 BEACON 1 AND SOUNDER STAGE 1 LINKED ; BEACON 2 AND SOUNDER STAGE 2 LINKED
 INDEPENDENT STAGE WIRING FOR ALARM HORN SOUNDER WITH END OF LINE MONITORING (2 STAGES)

ENTRY TERMINALS

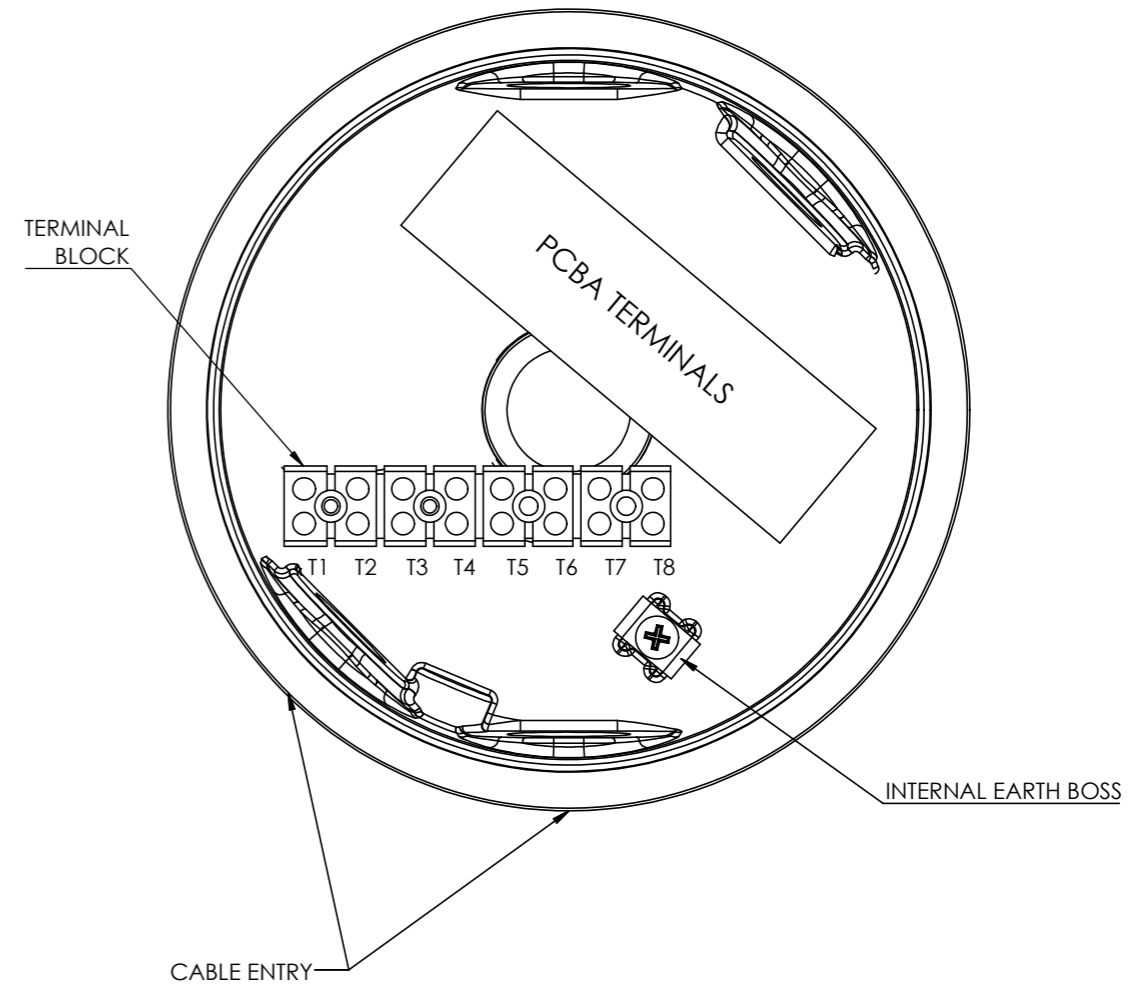
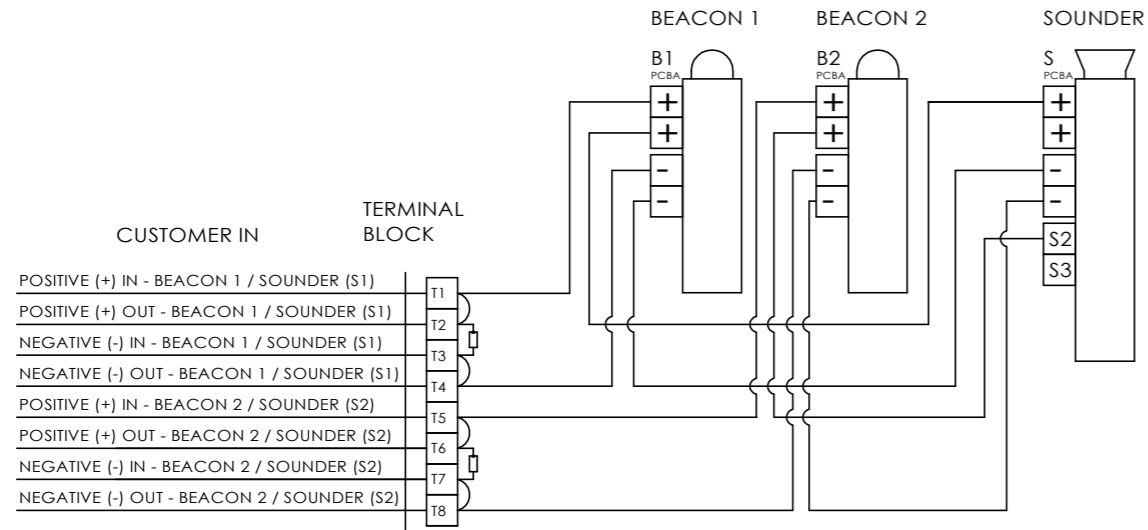

CONFIG. 6

DC VOLTAGE SUPPLY
 INDEPENDENT CONNECTIONS TO ALL SIGNALS
 INDEPENDENT STAGE WIRING FOR ALARM HORN SOUNDER WITH END OF LINE MONITORING (2 STAGES)

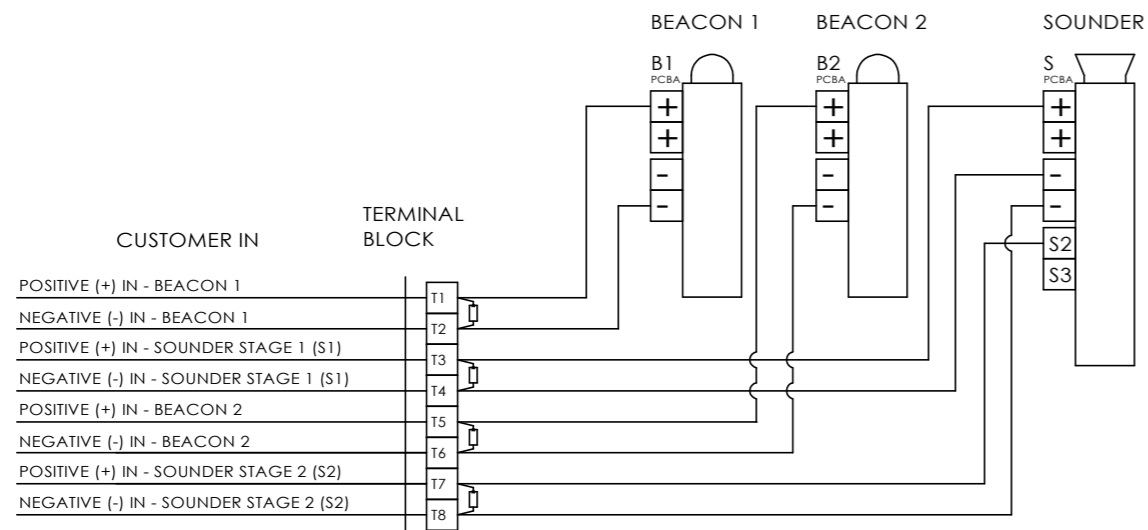

DRAWING TO BS8888:2000 GEOMETRIC TOLERANCES TO ISO1101:1983 LINEAR DIMENSIONAL TOLS ANGULAR DIMENSIONAL TOLS	DRAWN D.HOWGILL	DATE 15-08-2019	SURFACE FINISH FINISH	WEIGHT (kg)	THIS DRAWING AND ANY INFORMATION OR DESCRIPTIVE MATTER THEREIN IS COMMUNICATED IN CONFIDENCE AND IS THE COPYRIGHT PROPERTY OF EUROPEAN SAFETY SYSTEMS LTD. NEITHER THE WHOLE OR ANY EXTRACT MAY BE DISCLOSED, LOANED, COPIED OR USED FOR MANUFACTURING OR TENDERING PURPOSES WITHOUT THEIR WRITTEN CONSENT.	 EUROPEAN SAFETY SYSTEMS LTD IMPRESS HOUSE MANSELL ROAD ACTON LONDON W3 7QH WWW.E2S.COM	ALL DIMENSIONS IN MM IF IN DOUBT, ASK - DO NOT SCALE	 A2
	CHECKED R.N.POTTS	DATE 15-08-2019					TITLE D1xC3 STACK - 2 BEACONS & ALARM HORN WIRING SCHEMATIC	
	APPROVED R.N.POTTS	DATE 15-08-2019					ALTERNATIVE MATERIAL	

AC CONFIGURATIONS

ISSUE	MOD No.	REASON - INITIAL - DATE
2		SEE SH1
3		SEE SH1
4		SEE SH1

CONFIG. 1 (DEFAULT)

- AC VOLTAGE SUPPLY
- COMMON NEUTRAL CONNECTION TO ALL SIGNALS
- COMMON STAGE SWITCHING FOR ALARM HORN SOUNDER

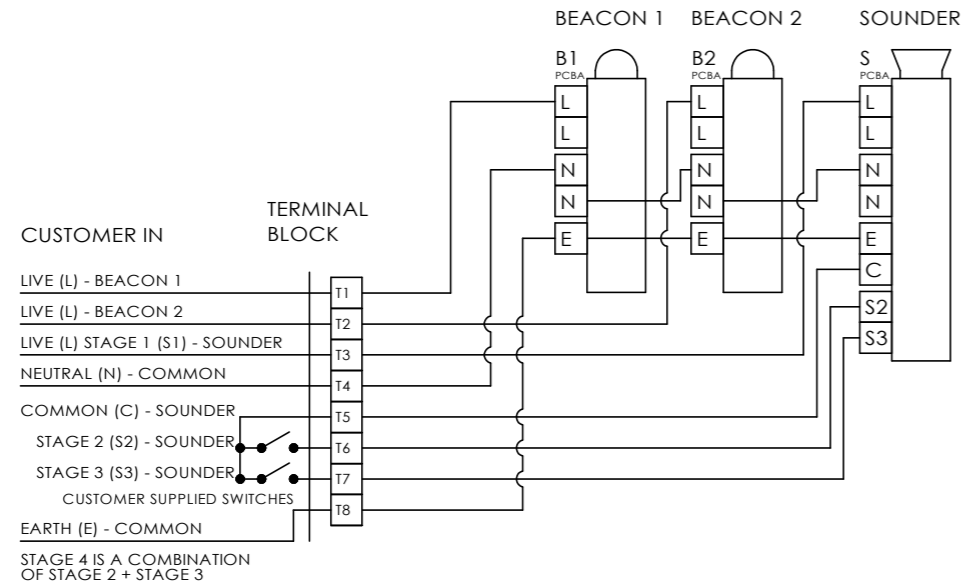

CONFIG. 2

- AC VOLTAGE SUPPLY
- INDEPENDENT CONNECTIONS TO ALL SIGNALS
- COMMON STAGE SWITCHING FOR ALARM HORN SOUNDER (2 STAGES)

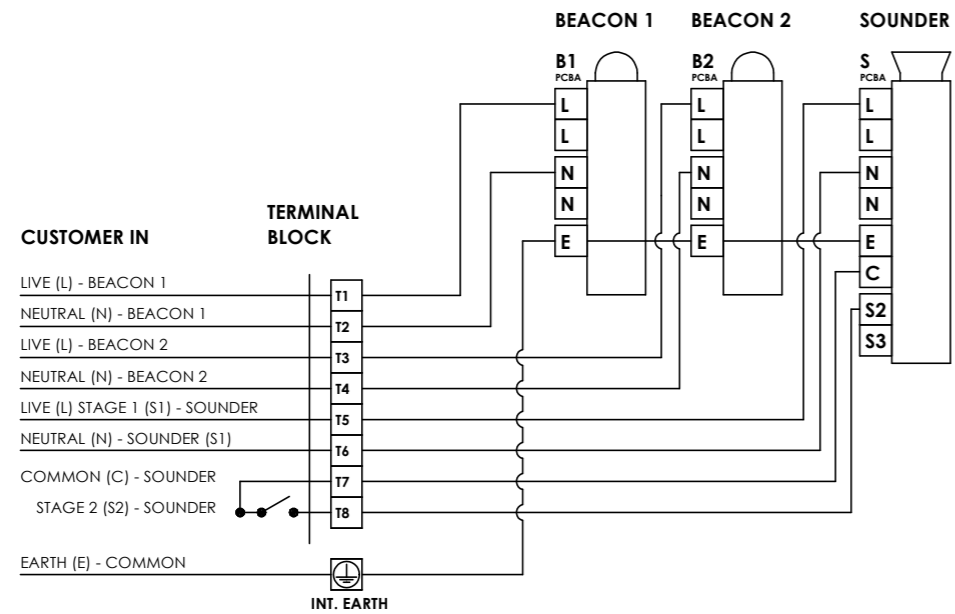

DRAWING TO BS8888:2000
GEOMETRIC TOLERANCES TO ISO1101:1983
LINEAR DIMENSIONAL TOLS
ANGULAR DIMENSIONAL TOLS

DRAWN	DATE
D.HOWGILL	15-08-2019
CHECKED	DATE
R.N.POTTS	15-08-2019
APPROVED	DATE
R.N.POTTS	15-08-2019

SURFACE FINISH	WEIGHT (kg)
FINISH	
MATERIAL	
ALTERNATIVE MATERIAL	

THIS DRAWING AND ANY INFORMATION OR DESCRIPTIVE MATTER THEREIN IS COMMUNICATED IN CONFIDENCE AND IS THE COPYRIGHT PROPERTY OF EUROPEAN SAFETY SYSTEMS LTD. NEITHER THE WHOLE OR ANY EXTRACT MAY BE DISCLOSED, LOANED, COPIED OR USED FOR MANUFACTURING OR TENDERING PURPOSES WITHOUT THEIR WRITTEN CONSENT.

EUROPEAN SAFETY SYSTEMS LTD.
AS PER LATEST DATE OF ISSUE SHOWN ABOVE

e2s
warning signals
EUROPEAN SAFETY SYSTEMS LTD
IMPRESS HOUSE
MANSELL ROAD
ACTON
LONDON W3 7QH
WWW.E2S.COM

ALL DIMENSIONS IN MM
IF IN DOUBT, ASK -
DO NOT SCALE

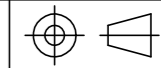

A2

TITLE D1xC3 STACK - 2 BEACONS & ALARM HORN WIRING SCHEMATIC

SCALE	SHEET	DRAWING NUMBER
NTS	3 OF 3	D226-06-135