

INSTRUCTION MANUAL

D1xP2 Status Light

2 Beacons with Junction Box

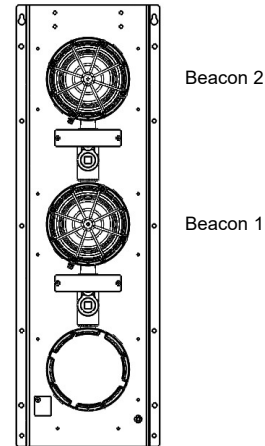
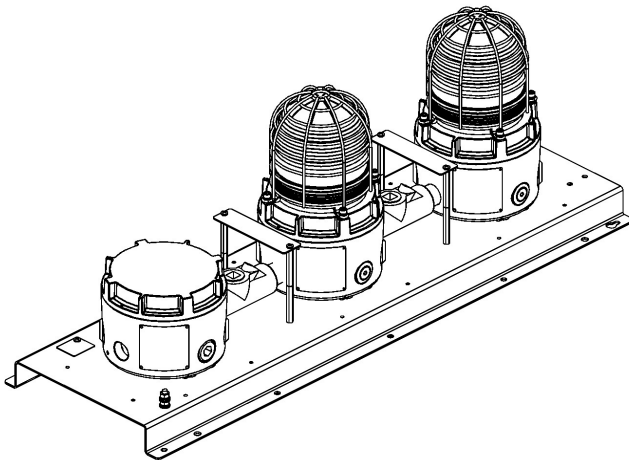

1) Warnings

Please see individual product instruction manual. See Table 1 for Instruction Manual Document Number.

2) Rating & Marking Information

Please see individual product instruction manual. See Table 1 for Instruction Manual Document Number.

All individual unit ratings must be suitable for the installation.

3) Type Approval Standards

Please see individual product instruction manual. See Table 1 for Instruction Manual Document Number.

4) Installation Requirements

Please see individual product instruction manual. See Table 1 for Instruction Manual Document Number.

5) Special Conditions of Use

Please see individual product instruction manual. See Table 1 for Instruction Manual Document Number.

| Component Part Code Reference | Component Description | Document Number |
|-------------------------------|-------------------------|-----------------|
| D1XJ2 | Junction Box | D191-00-501-IS |
| D1XB2X05 | 5J Xenon Strobe Beacon | D191-00-201-IS |
| D1XB2X10 | 10J Xenon Strobe Beacon | |
| D1XB2X15 | 15J Xenon Strobe Beacon | |
| D1XB2X21 | 21J Xenon Strobe Beacon | |
| D1XB2LD2 | LED Beacon | D191-00-401-IS |

Table 1: Product Instruction Manual Reference

6) Part Coding

| Part Code: | Identifier - Description |
|---|---|
| Product Type | D1xP2 |
| Junction Box | J2 = Junction Box |
| Beacon Type (Add Code for each Beacon in Status Light) | 1Y = D1xB2X05 2Y = D1xB2X10 3Y = D1xB2X15 4Y = D1xB2X21 5Y = D1xB2LD2 Where Y = Lens Colour, choose from: A = Amber, B = Blue, C = Clear, G = Green, M = Magenta, R = Red, Y = Yellow |
| Voltage | DC024 = 24Vdc DC048 = 48Vdc (Xenon Beacons Only) AC115 = 115-120Vac 50/60Hz AC230 = 220-230Vac 50/60Hz |
| Cable Entries [e] | A = 1 x M20x1.5mm + 1 x M20 (Adaptor) B = 2 x 1/2" NPT (Adaptors) C = 1 x 3/4" NPT + 1 x 3/4" NPT (Adaptor) D = 2 x M25x1.5mm (Adaptors) E = 1 x 1/2" NPT (Adaptor) + 1 x M20x1.5mm F = 1 x 1/2" NPT (Adaptor) + 1 x 3/4" NPT G = 1 x M25x1.5mm (Adaptor) + 1 x M20 M = 1 x 3/4" NPT + 1 x M20x1.5mm - Default All Junction Boxes have additional 2 x 3/4" NPT Side Entries |
| Stopping Plug / Adaptor Material [m] | B = Brass N = Nickel Plated S = Stainless Steel |
| Guard / Tag Material [s] | 1 = 316 St. Steel Guard & 316 Tag 2 = As (1) with Traffic Light Cowl 3 = 316 St. Steel Guard, 316 Tag & Duty Labels 4 = As (5) with Traffic Light Cowl 5 = 316 St. Steel Guard, 316 Tag & Duty Labels attached by steel wire |
| Product Version [v] | A = ATEX/IECEX/UL/cUL Class 1 Zone 1 B = ATEX / IECEX C = UL/cUL Class Div 1 |
| Product Option [o] | 1 = Standard Wiring 2 = Independent Wiring W = Special Wiring X = Special Configuration |
| Assembly Colour [x] | R = Red, G = Grey Other colours also possible, contact E2S sales |

7) Location and Mounting

The location of the Status Light should be made with due regard to the area over which the warning signal must be visible/audible. They should only be fixed to surfaces that can carry the weight of the unit.

The D1xP2 Status Light should be secured to any flat surface using ten Ø7mm fixing holes in the mounting plate. See figure 1.

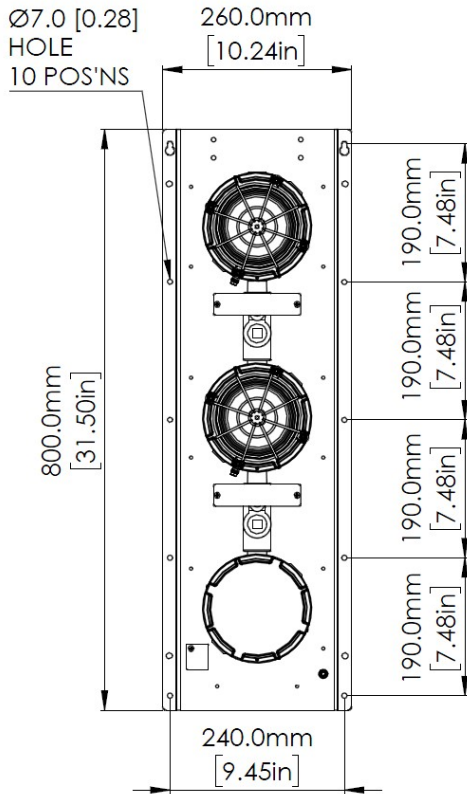

Fig. 1: Mounting Detail and Dimensions for D1x Status Light

Alternatively, the unit can be pole mounted. For pole mounting detailed instructions, see drawing D226-00-010

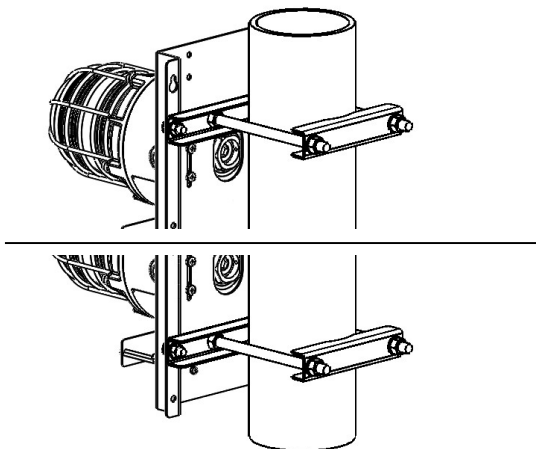

Fig. 2: Pole Mounted Unit
Max. Pole size NPS 4"
(OD: Ø114.3mm / 4.5in)

8) Access to the Enclosure



Warning – Hot surfaces. External surfaces and internal components may be hot after operation, take care when handling the equipment.

In order to connect the electrical supply cables to the beacon, it is necessary to open the explosion proof enclosure. Loosen the locking grub screw in the cover and then remove the glass dome cover assembly to gain access to the chamber. This can be achieved by unscrewing the glass dome cover, taking extreme care not to damage the threads when doing so.

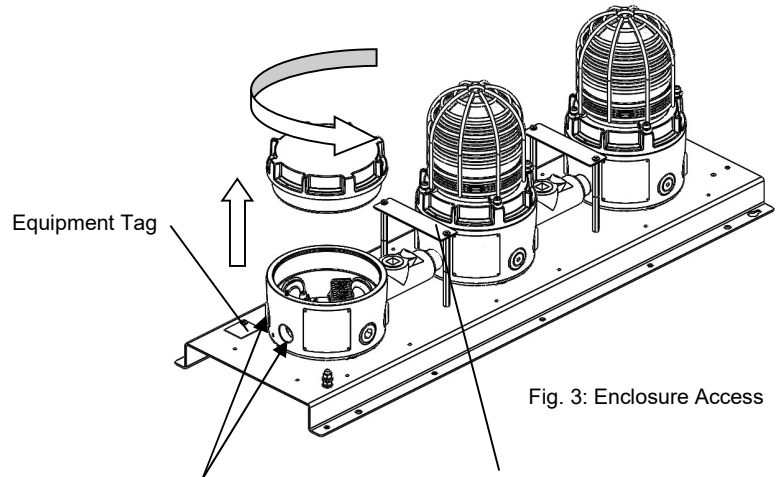

1 x 3/4" NPT & 1 x M20x1.5mm
Cable Entry (Or Adapters if
selected)

Fig. 3: Enclosure Access

9) Power Supply Selection

For Voltage ranges of complete units, take the highest Minimum value and lowest Maximum value in the ranges of the component units. For Current and Max Current ratings of complete units, add the ratings from the component units.

Please see individual product instruction manual for Voltage Range, Current and Max Current values.

10) Selection of Cable, Cable Glands, Blanking Elements & Adapters

Please see individual product instruction manual.

NOTE: Stopping plugs cannot be fitted into adaptors.

11) Earthing

The Status Light is provided with an M6 earth screw on the mounting plate. Earthing connections should be made to the M6 earth screw, using a ring crimp terminal to secure the earth conductor.

Please see individual product instruction manual for details of earthing each beacon

12) Cable Connections

Electrical connections are to be made into the DIN terminals in the junction box. See section 8 of this manual for access to the enclosure.

Wires having a cross sectional area between 0.5 mm² to 2.5mm² can be connected to each terminal way. Strip wires to 8mm. Wires may also be fitted using ferrules. Terminal screws need to be tightened down with a tightening torque of 0.45 Nm / 5 Lb-in. When connecting wires to the terminals great care should be taken to dress the wires so that when the cover is inserted into the chamber the wires do not exert excess pressure on the terminal blocks. This is particularly important when using cables with large cross-sectional areas such as 2.5mm².

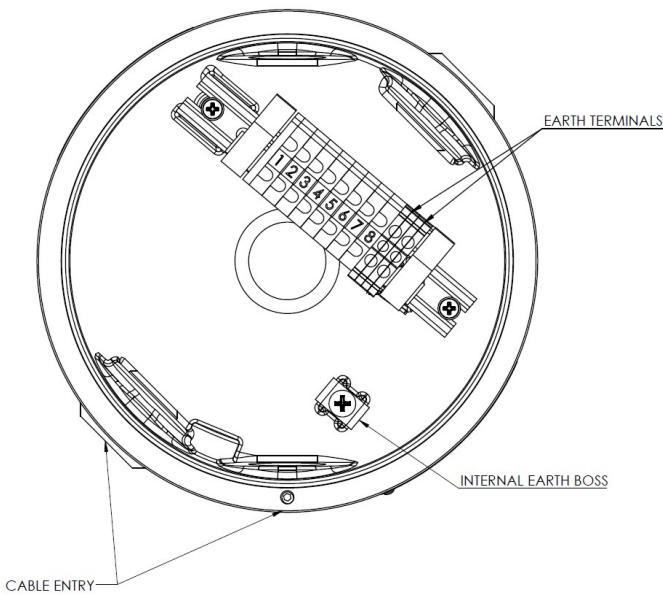

Fig. 4: Junction Box Internal Detail and DIN Terminals

13) Wiring

For wiring diagrams, see schematic document D226-06-122. See table 3 at the end of this manual for list of standard configurations.

Note:

For units with product codes where Product Option = X or W, please see special wiring schematic supplied with the unit documentation.

14) Interchangeable & Spare Parts

The Beacon lens cover is interchangeable, contact E2S Ltd for a replacement lens cover available in various colours.

To change the lens cover, unscrew the 4-off M5 socket head screws, spring and flat washers using a 4mm Hex key. Remove the wire guard and replace the old lens cover with the new lens cover.

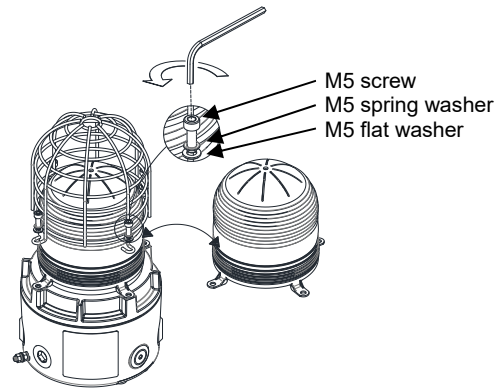

Fig. 5: Replacement of beacon lens cover

Fit the wire guard back onto the housing, over the new lens cover aligning the fixing holes of the guard, lens cover and housing. Refit the fixings to hold into place, the fixings **MUST** be fitted in the order shown above.

Optional Duty Labels can be placed to suit either the vertical mounting position (default) or a horizontal mounting position. See figure 6 for configuration details.

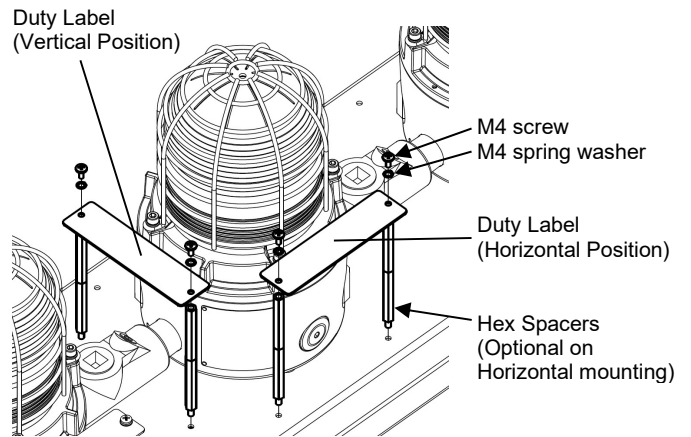
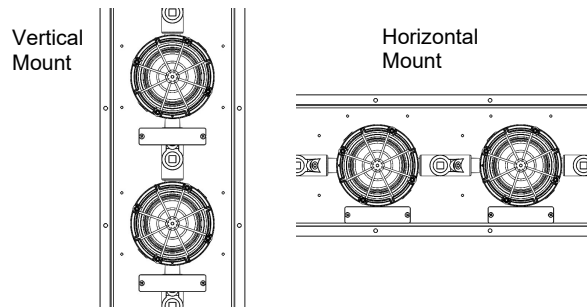

Fig. 6: Duty label assembly and configurations

To move the duty labels, use a spanner or equivalent tool to carefully remove the hex nuts and spring washers from the positions shown on the rear of the plate. Care should be taken not to drop them, especially if working from height.

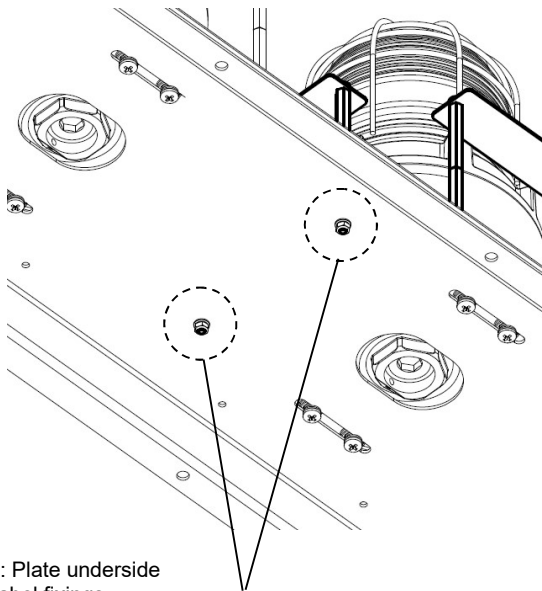

Fig. 7: Plate underside duty label fixings

M4 Hex Nut & Spring Washer

For horizontal mounting, the hex spacers are optional.

If using the hex spacers:

Position the duty label assembly in the desired position (fig. 6). Place spring washers over the spacer threads on the underside of the plate and tighten M4 hex nuts fully.

If not using hex spacers:

Carefully remove the duty labels from spacers using a positive-drive screwdriver to loosen the M4 screws. Place duty label flush to plate with screws inserted into holes (fig. 6). Place spring washers over the spacer threads on the underside of the plate (fig. 7) and tighten M4 hex nuts fully.

Beacons can be configured with a traffic light cowl to enhance visibility. Figure 8 shows the optional Traffic Light Cowl pre-assembled to the Beacon by E2S.

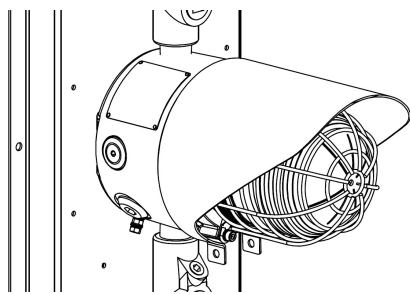

Fig. 8: Traffic Light Cowl

16) SIL Approvals

Beacons have been assessed for Reliability and Functional safety under IEC/EN61508 and are considered suitable for use in low demand safety functions:

1. Random Hardware Failures and Architectural constraints (route 2_H).
2. As an unvoted item (i.e. hardware fault tolerance of 0) at SIL 2.

Please see individual product instruction manual in Table 1 for information on reliability data.

15) Maintenance, Overhaul and Repair

Please see individual product instruction manual. See Table 1 for Instruction Manual Document Number.

| DC DIAGRAMS | | | | |
|-------------------------------------|----------------|----------------------------------|---|---------------------------|
| Config. | Voltage | Configuration Description | Features | Product Option [o] |
| 1 | DC | Standard wiring (Default) | <ul style="list-style-type: none"> Common negative connection to all signals | 1 |
| 2 | DC | Independent wiring | <ul style="list-style-type: none"> Independent wiring to all signals | 2 |
| AC DIAGRAMS | | | | |
| Config. | Voltage | Configuration Description | Features | Product Option [o] |
| 1 | AC | Standard wiring (Default) | <ul style="list-style-type: none"> Common neutral connection to all signals | 1 |
| 2 | AC | Independent wiring | <ul style="list-style-type: none"> Independent wiring to all signals | 2 |
| Table 3 – Summary of Wiring Options | | | | |

DC CONFIGURATIONS

E2S PART NO
D1x[P2][J2][XX][XX]
 Note: Alternative wiring configurations may be available on request - contact E2S sales

DESCRIPTION
D1xP2 STACK - 2 BEACONS
WITH JUNCTION BOX

DATA REFERENCE
1-26-070

| ISSUE | MOD No. | REASON - INITIAL - DATE |
|-------|---------|---|
| 1 | | INTRODUCTION DAH - 15-08-2019 |
| 2 | | -VE / N COMMON TERMINAL MOVED TO T3 - DAH - 26-02-2020 |
| 3 | | CONFIGS 1 - 2 ADDED. SH2 ADDED DAH - 11-04-2023 |

CONFIG. 1 (DEFAULT)

DC VOLTAGE SUPPLY
 COMMON NEGATIVE CONNECTION TO ALL SIGNALS

ENTRY TERMINALS

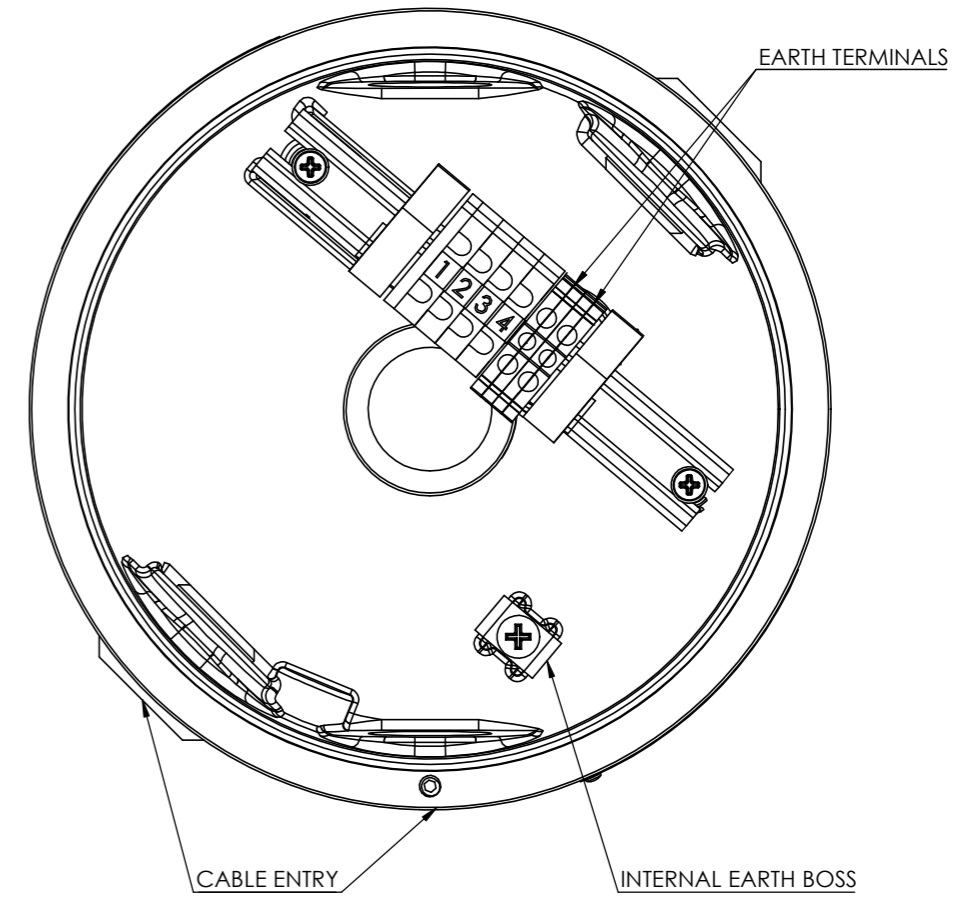
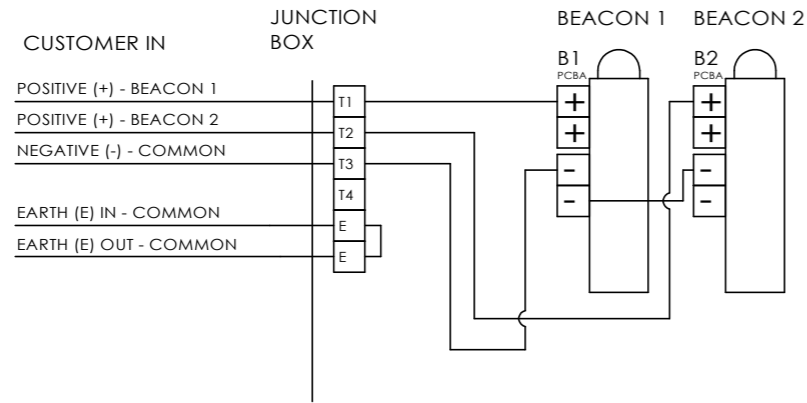

CONFIG. 2

DC VOLTAGE SUPPLY
 INDEPENDENT CONNECTIONS TO ALL SIGNALS

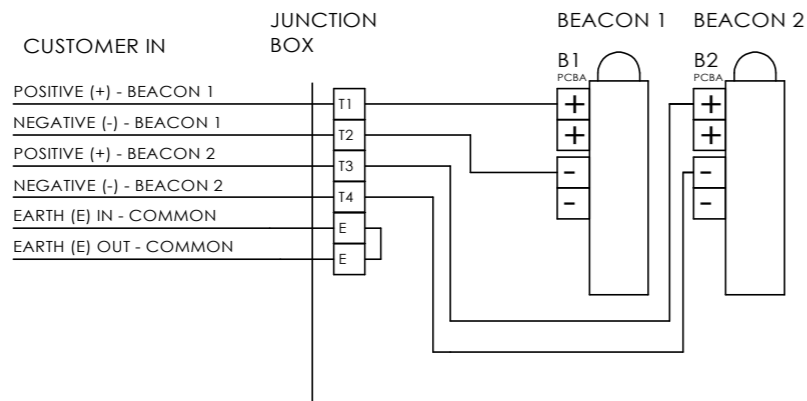

DRAWING TO BS8888:2000
 GEOMETRIC TOLERANCES TO ISO1101:1983
 LINEAR DIMENSIONAL TOLS
 ANGULAR DIMENSIONAL TOLS

| DRAWN | DATE |
|-----------|------------|
| D.HOWGILL | 15-08-2019 |
| CHECKED | DATE |
| R.N.POTTS | 15-08-2019 |
| APPROVED | DATE |
| R.N.POTTS | 15-08-2019 |

| SURFACE FINISH | WEIGHT (kg) |
|----------------------|-------------|
| FINISH | |
| MATERIAL | |
| ALTERNATIVE MATERIAL | |

THIS DRAWING AND ANY INFORMATION OR DESCRIPTIVE MATTER THEREIN IS COMMUNICATED IN CONFIDENCE AND IS THE COPYRIGHT PROPERTY OF EUROPEAN SAFETY SYSTEMS LTD. NEITHER THE WHOLE OR ANY EXTRACT MAY BE DISCLOSED, LOANED, COPIED OR USED FOR MANUFACTURING OR TENDERING PURPOSES WITHOUT THEIR WRITTEN CONSENT.

EUROPEAN SAFETY SYSTEMS LTD.
 AS PER LATEST DATE OF ISSUE SHOWN ABOVE

e2s
 warning signals
 EUROPEAN SAFETY SYSTEMS LTD
 IMPRESS HOUSE
 MANSELL ROAD
 ACTON
 LONDON W3 7QH
 WWW.E2S.COM

ALL DIMENSIONS IN MM
 IF IN DOUBT, ASK -
 DO NOT SCALE

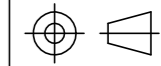

A2

TITLE D1xP2 STACK - 2 BEACONS WITH
 JUNCTION BOX WIRING SCHEMATIC

| SCALE | SHEET | DRAWING NUMBER |
|-------|--------|----------------|
| NTS | 1 OF 2 | D226-06-122 |

AC CONFIGURATIONS

| ISSUE | MOD No. | REASON - INITIAL - DATE |
|-------|---------|-------------------------|
| 1 | | SEE SH1 |
| 2 | | SEE SH1 |
| 3 | | SEE SH1 |

CONFIG. 1 (DEFAULT)

AC VOLTAGE SUPPLY
COMMON NEUTRAL CONNECTION TO ALL SIGNALS

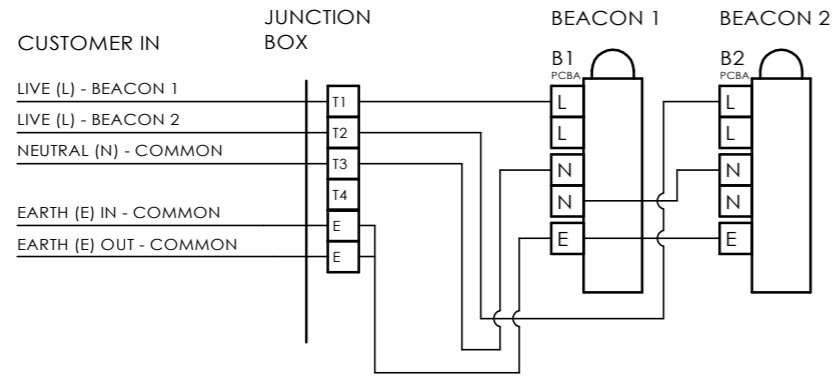

CONFIG. 2

AC VOLTAGE SUPPLY
INDEPENDENT CONNECTIONS TO ALL SIGNALS

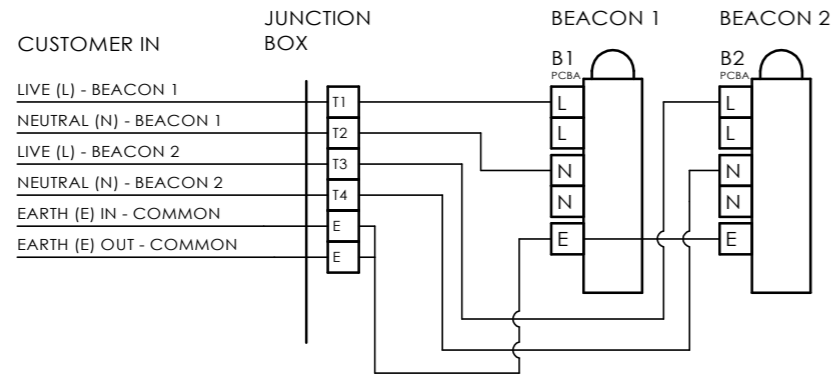

DRAWING TO BS8888:2000
GEOMETRIC TOLERANCES TO ISO1101:1983
LINEAR DIMENSIONAL TOLS
ANGULAR DIMENSIONAL TOLS

| | |
|-----------|------------|
| DRAWN | DATE |
| D.HOWGILL | 15-08-2019 |
| CHECKED | DATE |
| R.N.POTTS | 15-08-2019 |
| APPROVED | DATE |
| R.N.POTTS | 15-08-2019 |

| | |
|----------------------|-------------|
| SURFACE FINISH | WEIGHT (kg) |
| FINISH | |
| MATERIAL | |
| ALTERNATIVE MATERIAL | |

THIS DRAWING AND ANY INFORMATION OR DESCRIPTIVE MATTER THEREIN IS COMMUNICATED IN CONFIDENCE AND IS THE COPYRIGHT PROPERTY OF EUROPEAN SAFETY SYSTEMS LTD. NEITHER THE WHOLE OR ANY EXTRACT MAY BE DISCLOSED, LOANED, COPIED OR USED FOR MANUFACTURING OR TENDERING PURPOSES WITHOUT THEIR WRITTEN CONSENT.

EUROPEAN SAFETY SYSTEMS LTD.
AS PER LATEST DATE OF ISSUE SHOWN ABOVE

e2s
warning signals

EUROPEAN SAFETY SYSTEMS LTD
IMPRESS HOUSE
MANSELL ROAD
ACTON
LONDON W3 7QH
WWW.E2S.COM

| | | | |
|---|--------|----------------|-----------|
| ALL DIMENSIONS IN MM IF IN DOUBT, ASK - DO NOT SCALE | | | A2 |
| TITLE D1xP2 STACK - 2 BEACONS WITH JUNCTION BOX WIRING SCHEMATIC | | | |
| SCALE | SHEET | DRAWING NUMBER | |
| NTS | 2 OF 2 | D226-06-122 | |