

# INSTRUCTION MANUAL

## D1xP2 Status Light

### 4 Beacons

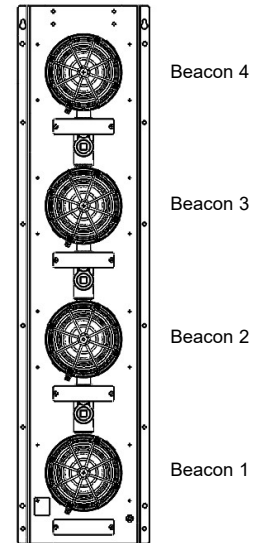
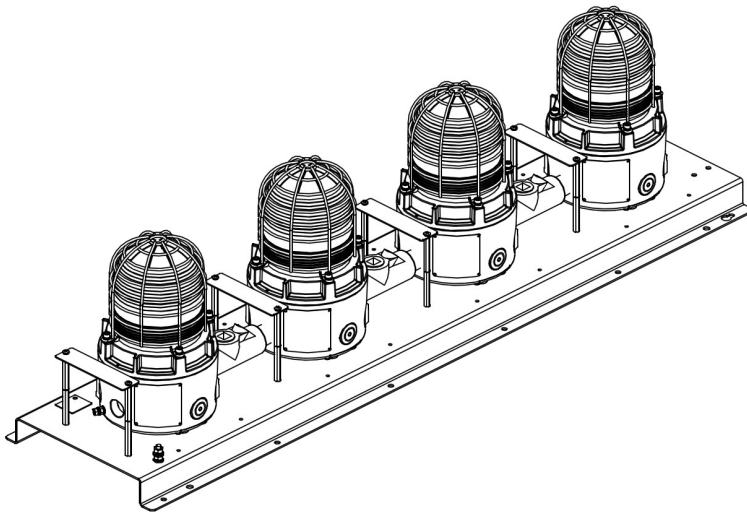

### 1) Warnings

Please see individual product instruction manual. See Table 1 for Instruction Manual Document Number.

### 2) Rating & Marking Information

Please see individual product instruction manual. See Table 1 for Instruction Manual Document Number.

All individual unit ratings must be suitable for the installation.

### 3) Type Approval Standards

Please see individual product instruction manual. See Table 1 for Instruction Manual Document Number.

### 4) Installation Requirements

Please see individual product instruction manual. See Table 1 for Instruction Manual Document Number.

### 5) Special Conditions of Use

Please see individual product instruction manual. See Table 1 for Instruction Manual Document Number.

### 6) Part Coding

Part Code:	Identifier - Description
Product Type	D1xP2
Junction Box	N2 = No Junction Box
Beacon Type (Add Code for each Beacon in status light)	1Y = D1xB2X05 2Y = D1xB2X10 3Y = D1xB2X15 5Y = D1xB2LD2 Where Y = Lens Colour, choose from: A = Amber, B = Blue, C = Clear, G = Green, M = Magenta, R = Red, Y = Yellow
Voltage	DC024 = 24Vdc DC048 = 48Vdc (Xenon Beacons Only) AC115 = 115-120Vac 50/60Hz AC230 = 220-230Vac 50/60Hz
Cable Entries [e]	A = 1 x M20x1.5mm + 1 x M20 (Adaptor) B = 2 x 1/2" NPT (Adaptors) C = 1 x 3/4" NPT + 1 x 3/4" NPT (Adaptor) D = 2 x M25x1.5mm (Adaptors) E = 1 x 1/2" NPT (Adaptor) + 1 x M20x1.5mm F = 1 x 1/2" NPT (Adaptor) + 1 x 3/4" NPT G = 1 x M25x1.5mm (Adaptor) + 1 x M20 M = 1 x 3/4" NPT + 1 x M20x1.5mm - Default
Stopping Plug / Adaptor Material [m]	B = Brass N = Nickel Plated S = Stainless Steel
Guard / Tag Material [s]	1 = 316 St.Steel Guard & 316 Tag 3 = 316 St.Steel Guard, 316 Tag & Duty Labels 5 = 316 St.Steel Guard, 316 Tag & Duty Labels attached by steel wire
Product Version [v]	A = IECEx/ATEX/UL/cUL Class I Zone 1 B = IECEx/ATEX C = UL/cUL Class Div 1
Product Option [o]	1 = Standard Wiring 2 = Independent Wiring W = Special Wiring X = Special Configuration
Assembly Colour [x]	R = Red, G = Grey Other colours also possible, contact E2S sales

Component Part Code Reference	Component Description	Document Number
D1XB2X05	5J Xenon Strobe Beacon	D191-00-201-IS
D1XB2X10	10J Xenon Strobe Beacon	
D1XB2X15	15J Xenon Strobe Beacon	
D1XB2LD2	LED Beacon	D191-00-401-IS

Table 1: Product Instruction Manual Reference

## 7) Location and Mounting

The location of the Status Light should be made with due regard to the area over which the warning signal must be visible/audible. They should only be fixed to surfaces that can carry the weight of the unit.

The D1xP2 Status Light should be secured to any flat surface using twelve Ø7mm fixing holes in the mounting plate. See figure 1.

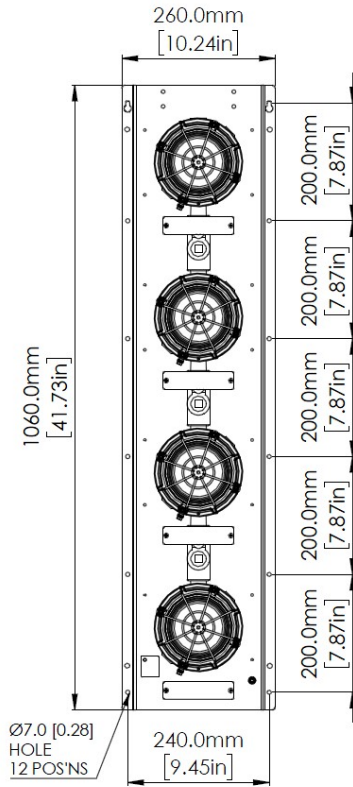

Fig.1: Mounting Detail and Dimensions for D1x Status Light

Alternatively, the unit can be pole mounted. For pole mounting detailed instructions, see drawing D226-00-010

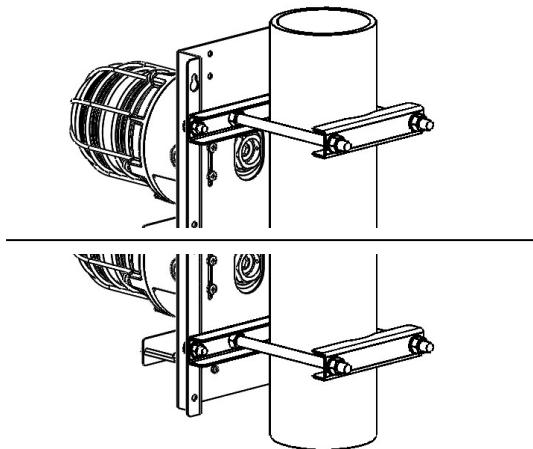

Fig. 2: Pole Mounted Status Light Max. Pole size NPS 4" (OD: Ø114.3mm / 4.5in)

## 8) Access to the Enclosure



Warning – Hot surfaces. External surfaces and internal components may be hot after operation, take care when handling the equipment.

In order to connect the electrical supply cables to the beacon, it is necessary to open the explosion proof enclosure. Loosen the locking grub screw in the cover and then remove the glass dome cover assembly to gain access to the chamber. This can be achieved by unscrewing the glass dome cover, taking extreme care not to damage the threads when doing so.

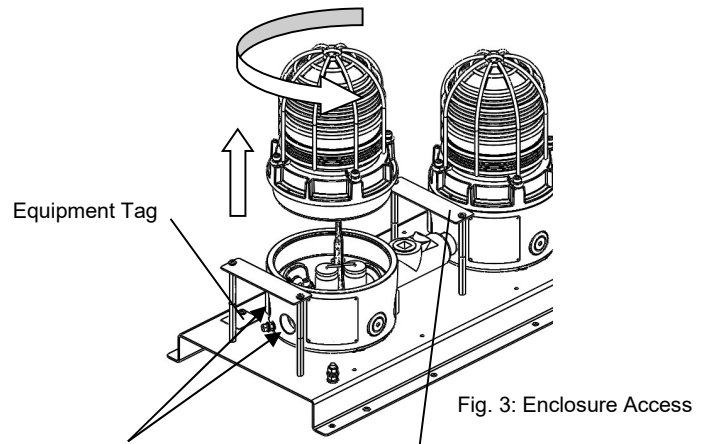

Fig. 3: Enclosure Access

1 x 3/4" NPT & 1 x M20x1.5mm Cable Entry (Or Adapters if selected)  
Optional Duty Labels

## 9) Power Supply Selection

For Voltage ranges of complete units, take the highest Minimum value and lowest Maximum value in the ranges of the component units. For Current and Max Current ratings of complete units, add the ratings from the component units.

Please see individual product instruction manual for Voltage Range, Current and Max Current values.

## 10) Selection of Cable, Cable Glands, Blanking Elements & Adapters

Please see individual product instruction manual.

NOTE: Stopping plugs cannot be fitted into adaptors.

## 11) Earthing

The Status Light is provided with an M6 earth screw on the mounting plate. Earthing connections should be made to the M6 earth screw, using a ring crimp terminal to secure the earth conductor.

Please see individual product instruction manual for details of earthing each beacon

## 12) Cable Connections

Electrical connections are to be made into the terminal block and PCBA located in the first beacon. See section 7 of this manual for access to the enclosure. See also individual manuals for detail on wiring into PCBA terminals.

Wires having a cross sectional area between 0.5 mm<sup>2</sup> to 2.5mm<sup>2</sup> can be connected to each terminal way. Strip wires to 8mm. Wires may also be fitted using ferrules. Terminal screws need to be tightened down with a tightening torque of 0.45 Nm / 5 Lb-in. When connecting wires to the terminals great care should be taken to dress the wires so that when the cover is inserted into the chamber the wires do not exert excess pressure on the terminal blocks. This is particularly important when using cables with large cross-sectional areas such as 2.5mm<sup>2</sup>.

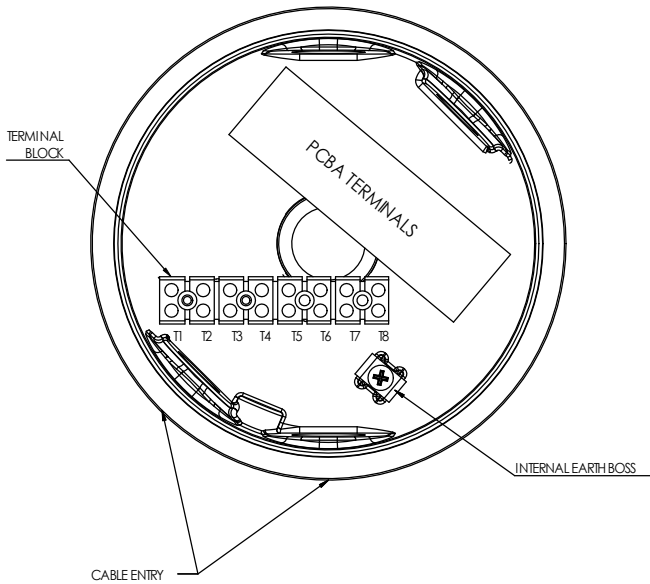

Fig. 4: Entry Unit (Beacon 1) Internal Detail & Terminal Block

## 13) Wiring

For wiring diagrams, see schematic document D226-06-140. See table 3 at the end of this manual for list of standard configurations.

### Note:

For units with product codes where Product Option = X or W, please see special wiring schematic supplied with the unit documentation.

## 14) Interchangeable & Spare Parts

The Beacon lens cover is interchangeable, contact E2S Ltd for a replacement lens cover available in various colours.

To change the lens cover, unscrew the 4-off M5 socket head screws, spring and flat washers using a 4mm Hex key. Remove the wire guard and replace the old lens cover with the new lens cover.

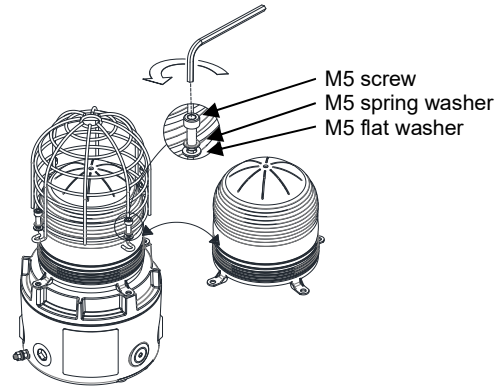

Fig. 5: Replacement of beacon lens cover

Fit the wire guard back onto the housing, over the new lens cover aligning the fixing holes of the guard, lens cover and housing. Refit the fixings to hold into place, the fixings MUST be fitted in the order shown above.

Optional Duty Labels can be placed to suit either the vertical mounting position (default) or a horizontal mounting position. See figure 6 for configuration details.

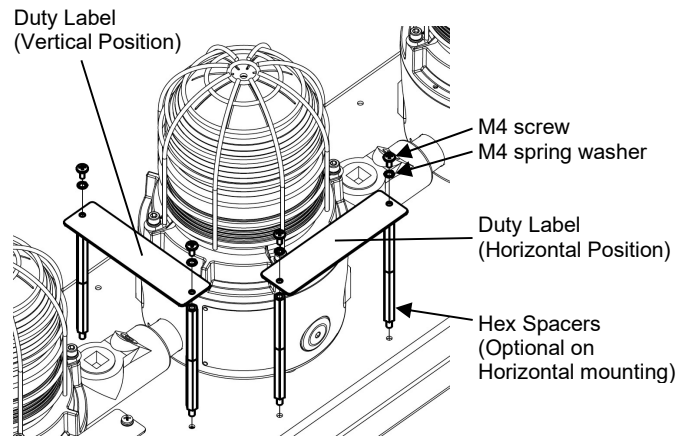
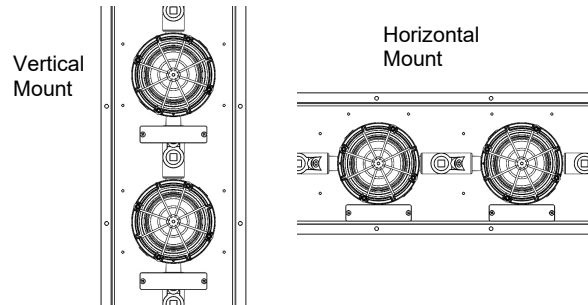

Fig. 6: Duty label assembly and configurations

To move the duty labels, use a spanner or equivalent tool to carefully remove the hex nuts and spring washers from the positions shown on the rear of the plate. Care should be taken not to drop them, especially if working from height.

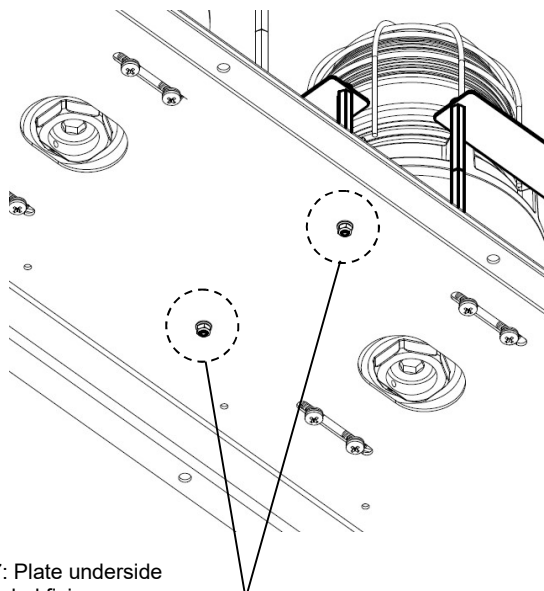

Fig. 7: Plate underside duty label fixings

M4 Hex Nut & Spring Washer

For horizontal mounting, the hex spacers are optional.

If using the hex spacers:

Position the duty label assembly in the desired position (fig. 6). Place spring washers over the spacer threads on the underside of the plate and tighten M4 hex nuts fully.

If not using hex spacers:

Carefully remove the duty labels from spacers using a posi-drive screwdriver to loosen the M4 screws. Place duty label flush to plate with screws inserted into holes (fig. 6). Place spring washers over the spacer threads on the underside of the plate (fig. 7) and tighten M4 hex nuts fully.

Beacons can be configured with a traffic light cowl to enhance visibility. Figure 8 shows the optional Traffic Light Cowl pre-assembled to the Beacon by E2S.

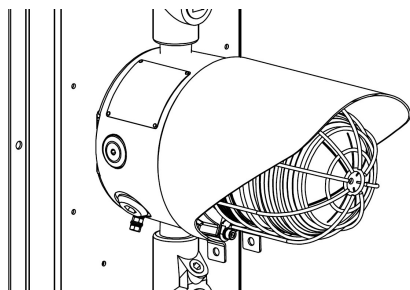

Fig. 8: Traffic Light Cowl

To disassemble the cowl, loosen the M6 Nut using a spanner or wrench and carefully remove from the beacon lid casting.

To re-assemble, manoeuvre the cowl back into position and tighten the M6 Screw and Nut until the cowl is fixed securely.

## 15) Maintenance, Overhaul and Repair

Please see individual product instruction manual. See Table 1 for Instruction Manual Document Number.

## 16) SIL Approvals

Beacons have been assessed for Reliability and Functional safety under IEC/EN61508 and are considered suitable for use in low demand safety functions:

1. Random Hardware Failures and Architectural constraints (route 2<sub>H</sub>).
2. As an unvoted item (i.e. hardware fault tolerance of 0) at SIL 2.

Please see individual product instruction manual in Table 1 for information on reliability data.

<b>DC DIAGRAMS</b>				
<b>Config.</b>	<b>Voltage</b>	<b>Configuration Description</b>	<b>Features</b>	<b>Product Option [o]</b>
1	DC	Standard wiring (Default)	<ul style="list-style-type: none"> <li>Common negative connection to all signals</li> </ul>	1
2	DC	Independent wiring	<ul style="list-style-type: none"> <li>Independent wiring to all signals</li> </ul>	2
<b>AC DIAGRAMS</b>				
<b>Config.</b>	<b>Voltage</b>	<b>Configuration Description</b>	<b>Features</b>	<b>Product Option [o]</b>
1	AC	Standard wiring (Default)	<ul style="list-style-type: none"> <li>Common neutral connection to all signals</li> </ul>	1
2	AC	Independent wiring	<ul style="list-style-type: none"> <li>Independent wiring to all signals</li> </ul>	2
Table 3 – Summary of Wiring Options				

# DC CONFIGURATIONS

**E2S PART NO**  
D1x[P2][N2][XX][XX][XX][XX]

**DESCRIPTION**  
D1xP2 STACK - 4 BEACONS

**DATA REFERENCE**  
1-26-070

Note: Alternative wiring configurations may be available on request - contact E2S sales

ISSUE	MOD No.	REASON - INITIAL - DATE
1		INTRODUCTION DAH - 15-08-2019
2		TB 8 TERMINALS WAS 6 : BEACON 1 CONNECTED TO TB. DAH - 24-02-2020
3		CONFIG 1-2 ADDED ; SH2 ADDED DAH - 20-04-2023

## CONFIG. 1 (DEFAULT)

DC VOLTAGE SUPPLY  
COMMON NEGATIVE CONNECTION TO ALL SIGNALS

## ENTRY TERMINALS

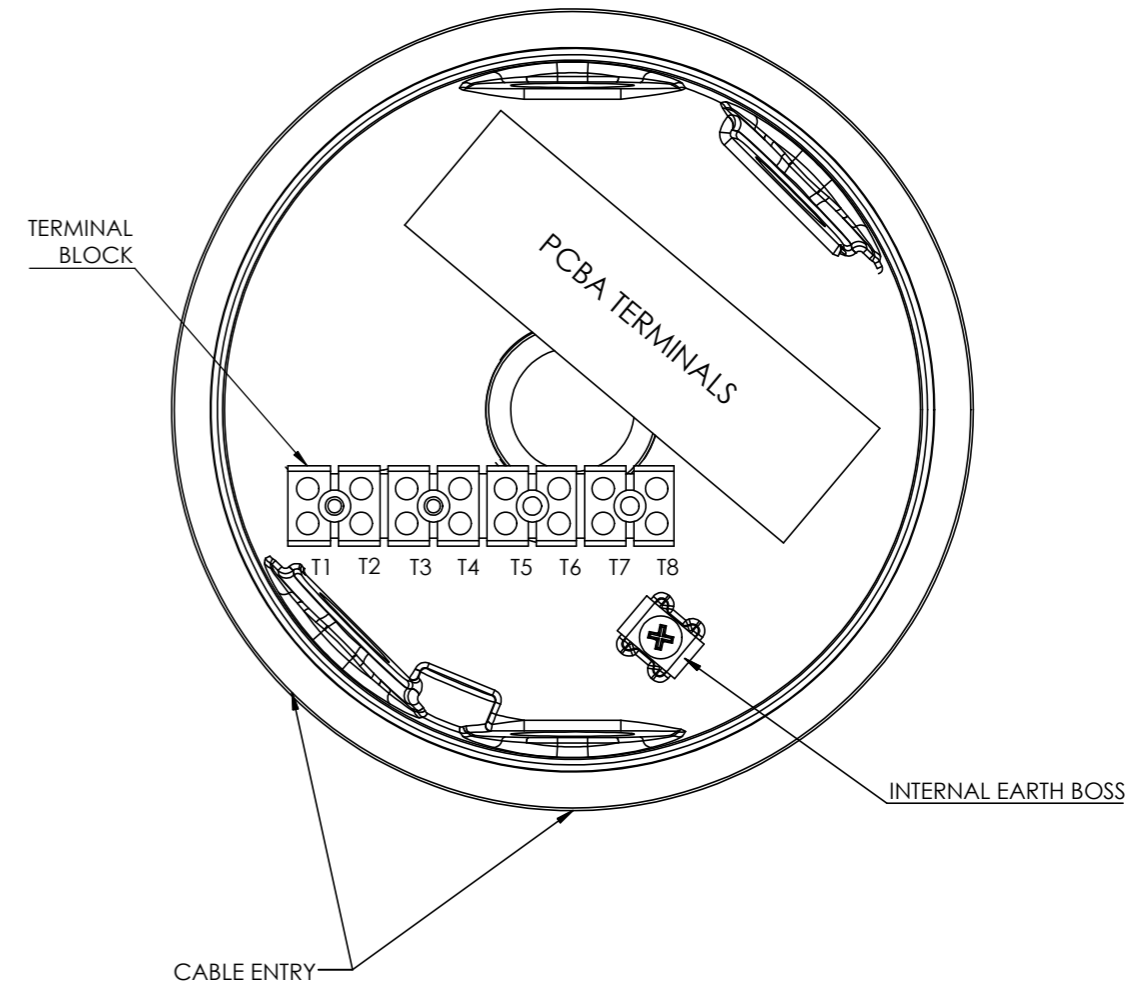
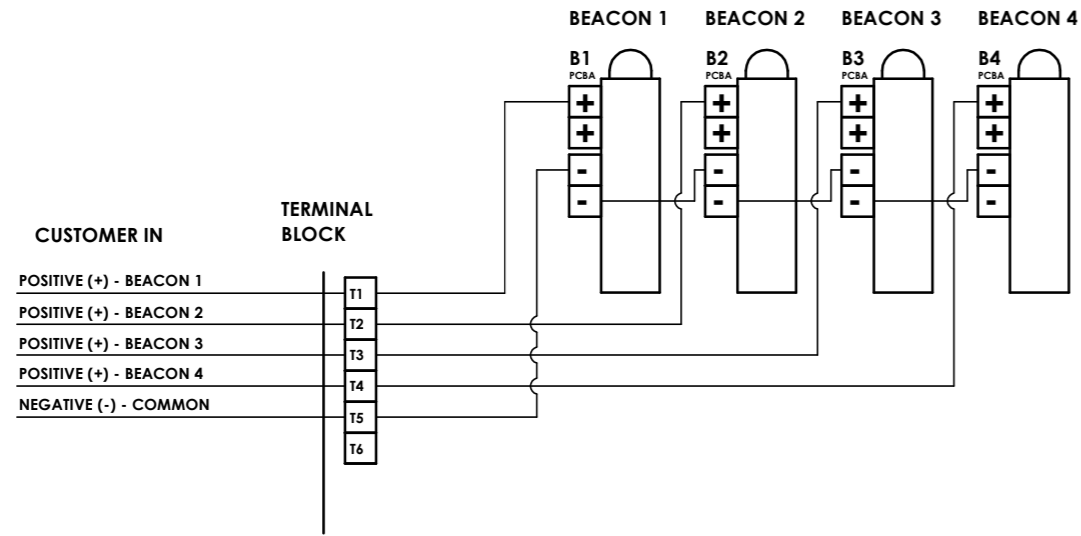

## CONFIG. 2

DC VOLTAGE SUPPLY  
INDEPENDENT CONNECTIONS TO ALL SIGNALS

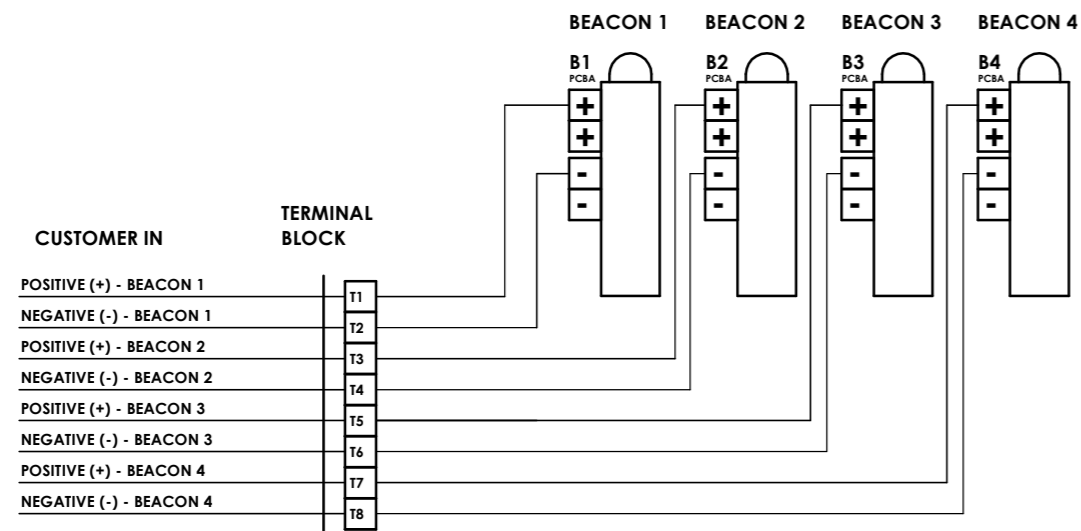

DRAWING TO BS8888:2000  
GEOMETRIC TOLERANCES TO ISO1101:1983  
LINEAR DIMENSIONAL TOLS  
ANGULAR DIMENSIONAL TOLS

DRAWN	DATE
D.HOWGILL	15-08-2019
CHECKED	DATE
R.N.POTTS	15-08-2019
APPROVED	DATE
R.N.POTTS	15-08-2019

SURFACE FINISH	WEIGHT (kg)
FINISH	
MATERIAL	
ALTERNATIVE MATERIAL	

THIS DRAWING AND ANY INFORMATION OR DESCRIPTIVE MATTER THEREIN IS COMMUNICATED IN CONFIDENCE AND IS THE COPYRIGHT PROPERTY OF EUROPEAN SAFETY SYSTEMS LTD. NEITHER THE WHOLE OR ANY EXTRACT MAY BE DISCLOSED, LOANED, COPIED OR USED FOR MANUFACTURING OR TENDERING PURPOSES WITHOUT THEIR WRITTEN CONSENT.

EUROPEAN SAFETY SYSTEMS LTD.  
AS PER LATEST DATE OF ISSUE SHOWN ABOVE

**e2s**  
warning signals  
EUROPEAN SAFETY SYSTEMS LTD  
IMPRESS HOUSE  
MANSELL ROAD  
ACTON  
LONDON W3 7QH  
WWW.E2S.COM

ALL DIMENSIONS IN MM  
IF IN DOUBT, ASK -  
DO NOT SCALE

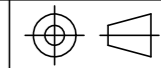

**A2**

TITLE D1xP2 STACK - 4 BEACONS  
WIRING SCHEMATIC

SCALE	SHEET	DRAWING NUMBER
NTS	1 OF 2	D226-06-140

# AC CONFIGURATIONS

ISSUE	MOD No.	REASON - INITIAL - DATE
1		SEE SH1
2		SEE SH1
3		SEE SH1

## CONFIG. 1 (DEFAULT)

AC VOLTAGE SUPPLY  
COMMON NEUTRAL CONNECTION TO ALL SIGNALS

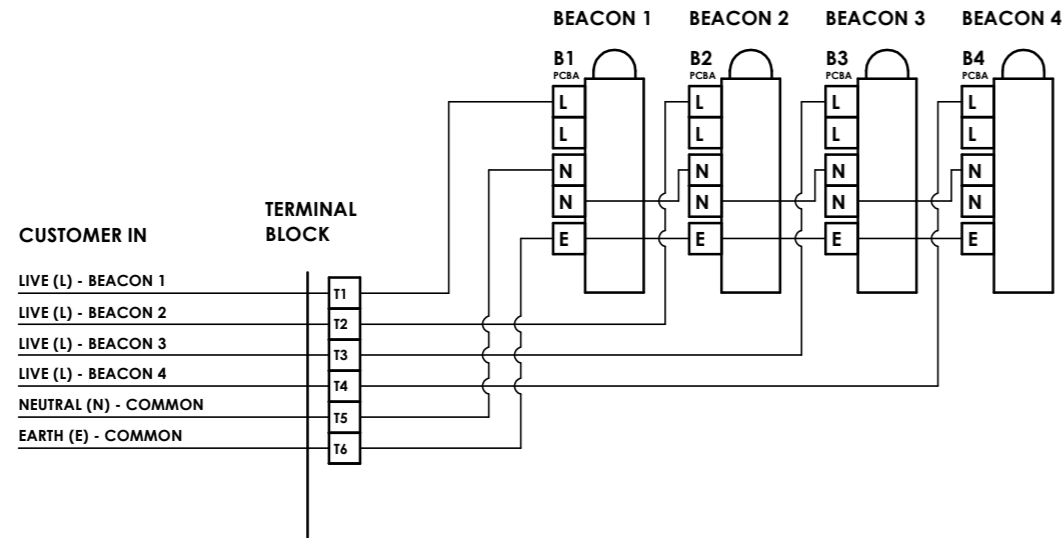

## CONFIG. 2

AC VOLTAGE SUPPLY  
INDEPENDENT CONNECTIONS TO ALL SIGNALS

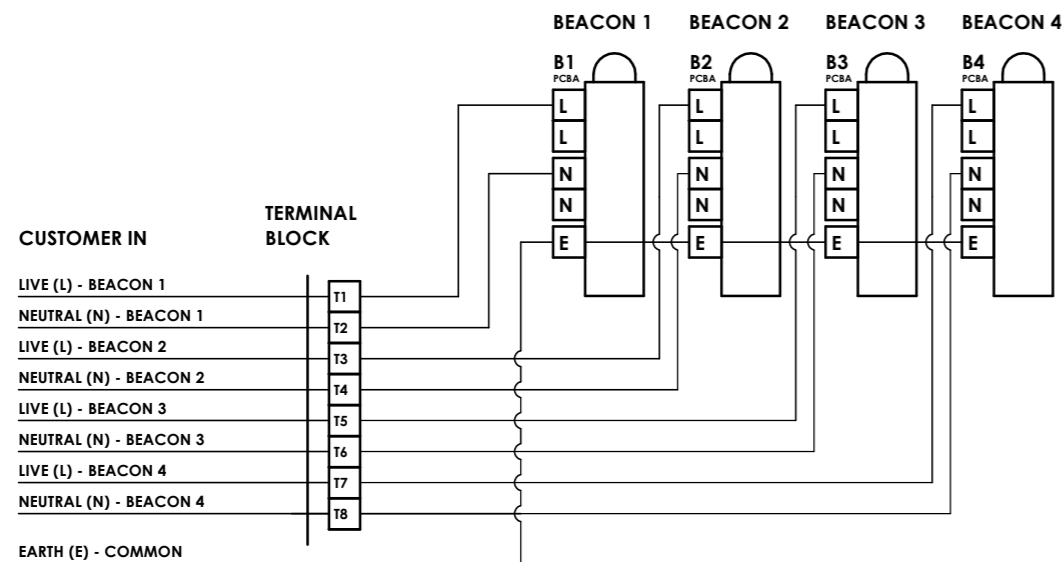

DRAWING TO BS8888:2000 GEOMETRIC TOLERANCES TO ISO1101:1983 LINEAR DIMENSIONAL TOLS ANGULAR DIMENSIONAL TOLS	DRAWN D.HOWGILL	DATE 15-08-2019	SURFACE FINISH FINISH	WEIGHT (kg)	THIS DRAWING AND ANY INFORMATION OR DESCRIPTIVE MATTER THEREIN IS COMMUNICATED IN CONFIDENCE AND IS THE COPYRIGHT PROPERTY OF EUROPEAN SAFETY SYSTEMS LTD. NEITHER THE WHOLE OR ANY EXTRACT MAY BE DISCLOSED, LOANED, COPIED OR USED FOR MANUFACTURING OR TENDERING PURPOSES WITHOUT THEIR WRITTEN CONSENT.	 EUROPEAN SAFETY SYSTEMS LTD IMPRESS HOUSE MANSELL ROAD ACTON LONDON W3 7QH WWW.E2S.COM	ALL DIMENSIONS IN MM IF IN DOUBT, ASK - DO NOT SCALE	 A2
	STANDARDS	CHECKED R.N.POTTS	DATE 15-08-2019	MATERIAL			TITLE D1xP2 STACK - 4 BEACONS WIRING SCHEMATIC	
		APPROVED R.N.POTTS	DATE 15-08-2019	ALTERNATIVE MATERIAL			SCALE NTS	

© EUROPEAN SAFETY SYSTEMS LTD.  
AS PER LATEST DATE OF ISSUE SHOWN ABOVE