

DC CONFIGURATIONS

E2S PART NO
D2x[P1][J1][XX][XX]
D2x[P1][J2][XX][XX]

DESCRIPTION
D2xP1 STACK - 2 BEACONS WITH JUNCTION BOX

DATA REFERENCE
1-35-010

Note: Alternative wiring configurations may be available on request - contact E2S sales

ISSUE	MOD No.	REASON - INITIAL - DATE
1		INTRODUCTION DAH - 15-08-2019
2		-VE / N COMMON MOVED TO T3 DAH - 21-02-2020
3		CONFIG 1-2 ADDED. SH2 ADDED DAH - 20/04/2023

CONFIG. 1 (DEFAULT)

DC VOLTAGE SUPPLY
 COMMON NEGATIVE CONNECTION TO ALL SIGNALS

ENTRY TERMINALS

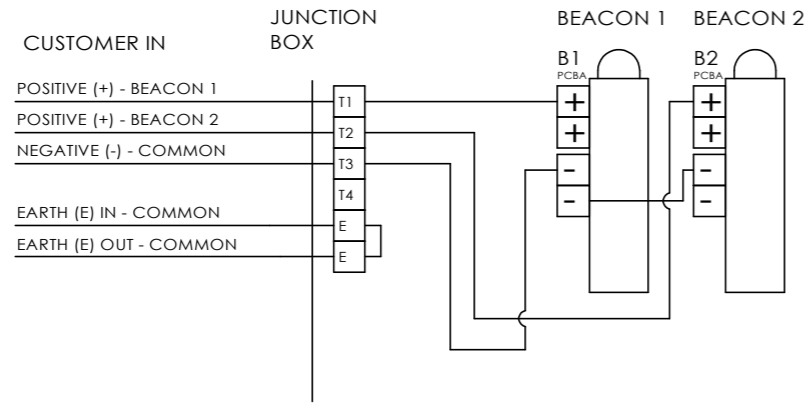

CONFIG. 2

DC VOLTAGE SUPPLY
 INDEPENDENT CONNECTIONS TO ALL SIGNALS

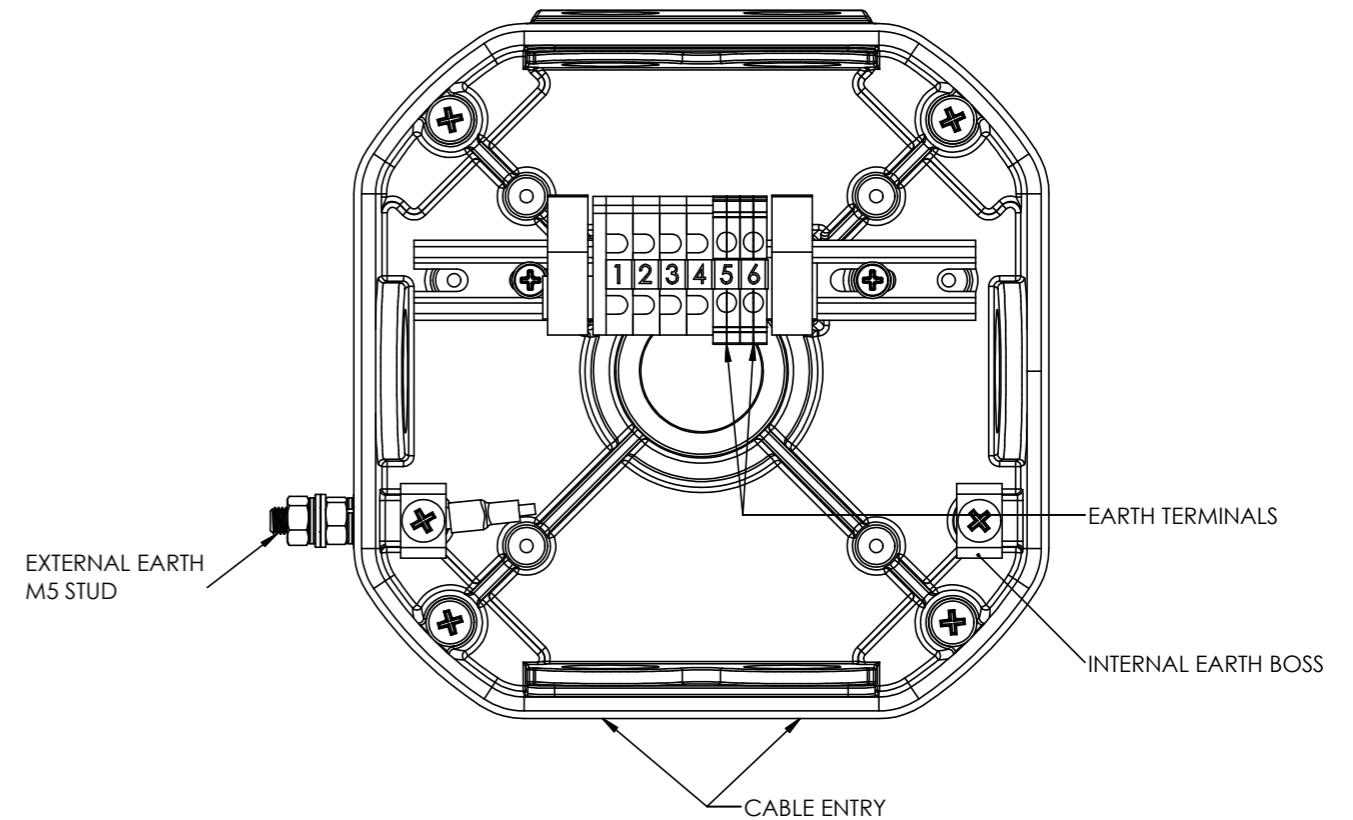
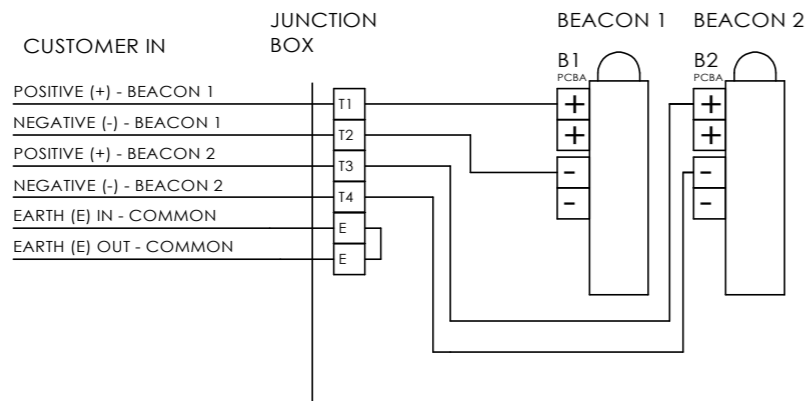

DRAWING TO BS8888:2000 GEOMETRIC TOLERANCES TO ISO1101:1983 LINEAR DIMENSIONAL TOLS ANGULAR DIMENSIONAL TOLS	DRAWN D.HOWGILL DATE 15-08-2019	SURFACE FINISH FINISH	WEIGHT (kg)
STANDARDS	CHECKED R.N.POTTS DATE 15-08-2019	MATERIAL	ALTERNATIVE MATERIAL
	APPROVED R.N.POTTS DATE 15-08-2019		

THIS DRAWING AND ANY INFORMATION OR DESCRIPTIVE MATTER THEREIN IS COMMUNICATED IN CONFIDENCE AND IS THE COPYRIGHT PROPERTY OF EUROPEAN SAFETY SYSTEMS LTD. NEITHER THE WHOLE OR ANY EXTRACT MAY BE DISCLOSED, LOANED, COPIED OR USED FOR MANUFACTURING OR TENDERING PURPOSES WITHOUT THEIR WRITTEN CONSENT.	EUROPEAN SAFETY SYSTEMS LTD. AS PER LATEST DATE OF ISSUE SHOWN ABOVE
EUROPEAN SAFETY SYSTEMS LTD. IMPRESS HOUSE MANSELL ROAD ACTON LONDON W3 7QH WWW.E2S.COM	

ALL DIMENSIONS IN MM IF IN DOUBT, ASK - DO NOT SCALE		A2
TITLE D2xP1 STACK - 2 BEACONS WITH JUNCTION BOX WIRING SCHEMATIC		
SCALE NTS	SHEET 1 OF 2	DRAWING NUMBER D215-06-132

AC CONFIGURATIONS

ISSUE	MOD No.	REASON - INITIAL - DATE
1		SEE SH1
2		SEE SH1
3		SEE SH1

CONFIG. 1 (DEFAULT)

AC VOLTAGE SUPPLY
COMMON NEUTRAL CONNECTION TO ALL SIGNALS

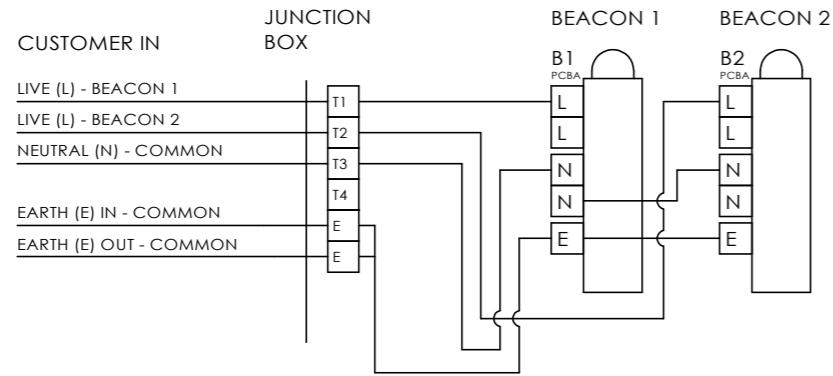

CONFIG. 2

AC VOLTAGE SUPPLY
INDEPENDENT CONNECTIONS TO ALL SIGNALS

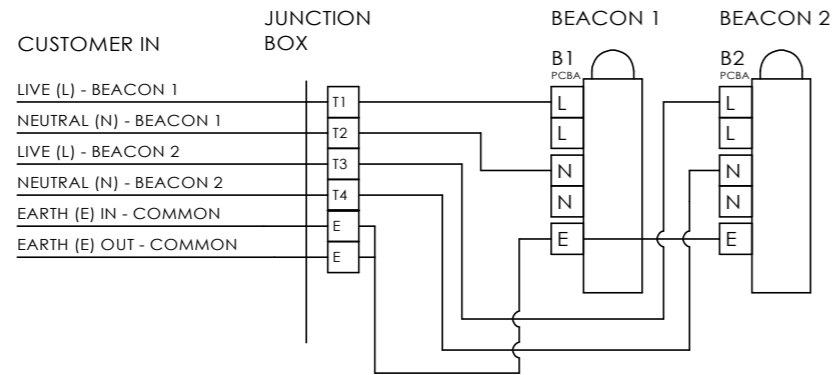

DRAWING TO BS8888:2000
GEOMETRIC TOLERANCES TO ISO1101:1983
LINEAR DIMENSIONAL TOLS
ANGULAR DIMENSIONAL TOLS

DRAWN	DATE
D.HOWGILL	15-08-2019
CHECKED	DATE
R.N.POTTS	15-08-2019
APPROVED	DATE
R.N.POTTS	15-08-2019

STANDARDS

SURFACE FINISH	WEIGHT (kg)
FINISH	
MATERIAL	
ALTERNATIVE MATERIAL	

THIS DRAWING AND ANY INFORMATION OR DESCRIPTIVE MATTER THEREIN IS COMMUNICATED IN CONFIDENCE AND IS THE COPYRIGHT PROPERTY OF EUROPEAN SAFETY SYSTEMS LTD. NEITHER THE WHOLE OR ANY EXTRACT MAY BE DISCLOSED, LOANED, COPIED OR USED FOR MANUFACTURING OR TENDERING PURPOSES WITHOUT THEIR WRITTEN CONSENT.

© EUROPEAN SAFETY SYSTEMS LTD.
AS PER LATEST DATE OF ISSUE SHOWN ABOVE



ALL DIMENSIONS IN MM
IF IN DOUBT, ASK -
DO NOT SCALE

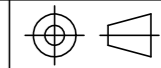

A2

TITLE D2xP1 STACK - 2 BEACONS WITH
JUNCTION BOX WIRING SCHEMATIC

SCALE	SHEET	DRAWING NUMBER
NTS	2 OF 2	D215-06-132