

INSTRUCTION MANUAL

D2xS2

Alarm Horn Sounder

Class I, Zone 2 & 22

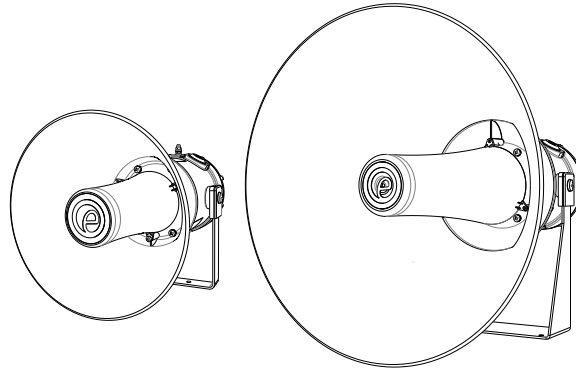

D2xS2F

D2xS2H

1) Product Table

Unit Type Code	Nominal Input Voltage	Nominal Current P2	Nominal Current P3	Voltage Range	Sound Pressure Level dB(A)	
					Max* P2/P3	Nom† P2/P3
D2xS2FDC024-A	12Vdc	289mA	356mA	11.5-54Vdc	120/123	117/120
	24Vdc	324mA	740mA			
	48Vdc	195mA	391mA			
D2xS2FAC230-A	115Vac	125mA	282mA	100-240Vac 50/60Hz	126/129	123/126
	230Vac	78mA	167mA			
D2xS2HDC024-A	12Vdc	289mA	356mA	11.5-54Vdc	126/129	123/126
	24Vdc	324mA	740mA			
	48Vdc	195mA	391mA			
D2xS2HAC230-A	115Vac	125mA	282mA	100-240Vac 50/60Hz	126/129	123/126
	230Vac	78mA	167mA			

*Max = Tone 4

†Nom. = Tone 44

The table shows the input current taken by the various sounders.

The current levels shown above are for the 440Hz Continuous tone @ nominal input voltage.

Nominal current at nominal voltage.

Table 1: Electrical Ratings.



2) Warnings:

DO NOT OPEN WHEN AN EXPLOSIVE
ATMOSPHERE IS PRESENT
DO NOT OPEN WHEN ENERGISED
POTENTIAL ELECTROSTATIC CHARGING
HAZARD - CLEAN ONLY WITH A DAMP
CLOTH

Avertissement:

NE PAS OUVRIR UN PRESENCE
D'ATMOSPHERE EXPLOSIVE
NE PAS OUVRIR ENERGIE
DANGER POTENTIEL CHARGE
ÉLECTROSTATIQUE - NETTOYER
UNIQUEMENT AVEC UN CHIFFON HUMIDE

3) Marking & Rating Information

3.1 UL Certification

All Sounders comply with the following standards:

UL 464A (Ed 1) – Audible Signal Appliances for General Signaling Use
CSA C22.2 No. 205-17 (Ed 3) –Signal Equipment

D2xS2-DC024-A Sounders also comply with the following standards:

UL 464 (Ed 10) – Audible Signaling Devices for Fire Alarm and
Signaling Systems, Including Accessories.
CAN/ULC-S525 (Ed 4) – Audible Signaling Devices for Fire Alarm and
Signaling Systems, Including Accessories.

See relevant sections further down.

The D2xS2 Alarm Horns comply with the following standards for
hazardous locations:

3.2 Class/Division & Class Zone Ratings for US & Canada

Class Division Ratings for US (NEC) & Canada (CEC)	
Standards:	UL 121201-2021 Edition 9 CAN/CSA C22.2 No. 213-17 Edition 3
Model No:	Rating
D2xS2FDC024 D2xS2HDC024	Class I, Div 2 ABCD T3C Ta -55°C to +85°C Class I, Div 2 ABCD T4 Ta -55°C to +60°C Class I, Div 2 ABCD T4A Ta -55°C to +45°C Class II, Div 2 FG T4 Ta -55°C to +85°C Class III Ta -55°C to +85°C
D2xS2FAC230 D2xS2HAC230	Class I, Div 2 ABCD T4 Ta -55°C to +85°C Class I, Div 2 ABCD T4A Ta -55°C to +75°C Class I, Div 2 ABCD T5 Ta -55°C to +55°C Class I, Div 2 ABCD T6 Ta -55°C to +40°C Class II, Div 2 FG T4 Ta -55°C to +85°C Class III Ta -55°C to +85°C
Class Zone Ratings for US (NEC)	
Standards:	UL 60079-0 Edition 7 UL 60079-7 Edition 5 UL 60079-31 Edition 2
Model No:	Rating
D2xS2FDC024 D2xS2HDC024	Class I Zone 2 AEx ec IIC T3 Gc Ta -55°C to +75°C Class I Zone 2 AEx ec IIC T4 Gc Ta -55°C to +50°C Zone 22 AEx tc IIIC T95°C Dc Ta -55°C to +75°C
D2xS2FAC230 D2xS2HAC230	Class I Zone 2 AEx ec IIC T4 Gc Ta -55°C to +75°C Class I Zone 2 AEx ec IIC T5 Gc Ta -55°C to +50°C Zone 22 AEx tc IIIC T93°C Dc Ta -55°C to +75°C
Class Zone Ratings for Canada (CEC)	
Standards:	CAN/CSA C22.2 No. 60079-0 Edition 4 CAN/CSA C22.2 No. 60079-7 Edition 2 CAN/CSA C22.2 No. 60079-31 Edition 2
Model No:	Rating
D2xS2FDC024 D2xS2HDC024	Ex ec IIC T3 Gc Ta -55°C to +75°C Ex ec IIC T4 Gc Ta -55°C to +55°C Ex tc IIIC T95°C Dc Ta -55°C to +75°C
D2xS2FAC230 D2xS2HAC230	Ex ec IIC T4 Gc Ta -55°C to +75°C Ex ec IIC T5 Gc Ta -55°C to +50°C Ex tc IIIC T93°C Dc Ta -55°C to +75°C
Installation must be carried out in compliance with the National Electric Code / Canadian Electric Code	

3.3 ATEX / IECEx & UKEx Ratings

Standards	
EN IEC 60079-0:2018 / IEC 60079-0:2017 Edition 7 EN IEC 60079-7:2015 +A1:2018 / IEC 60079-7:2018 Edition 5.1 EN 60079-31:2014 / IEC 60079-31:2022, Edition 3	
Model No:	Rating
D2xS2FDC024 D2xS2HDC024	Ex ec IIC T3 Gc Ta -55°C to +75°C Ex ec IIC T4 Gc Ta -55°C to +55°C Ex tc IIIC T95°C Dc Ta -55°C to +75°C
D2xS2FAC230 D2xS2HAC230	Ex ec IIC T4 Gc Ta -55°C to +75°C Ex ec IIC T5 Gc Ta -55°C to +50°C Ex tc IIIC T93°C Dc Ta -55°C to +75°C
See Product table for electrical ratings of each unit model	

Certificate No. DEMKO 14ATEX4786493904X
IECEX ULD 14.0004X
UKEx UL UL21UKEX2131X

Epsilon x
Equipment Group
and Category:



II 3G
II 3D

CE Marking and
Notified Body No.



UKCA Marking and
Notified Body No.

4) Zones, Gas Group, Category and Temperature Classification

The units can be installed in locations with the following conditions:

Area Classification Gas	
Zone 2	Explosive gas air mixture not likely to occur in normal operation, and if it does, it will only exist for a short time.
Gas Groupings	
Group IIA	Propane
Group IIB	Ethylene
Group IIC	Hydrogen and Acetylene
Temperature Classification for Gas Applications	
T1	450° C
T2	300° C
T3	200° C
T4	135° C (DC models limited to 55°C)
T5	100° C (AC models only to 50°C)
Area Classification Dust	
Zone 22	Explosive dust air mixture not likely to occur in normal operation, and if it does, it will only exist for a short time.
Dust Groupings	
Group IIIA	Combustible Dusts
Group IIIB	Non-Conductive Dusts
Group IIIC	Conductive Dusts
Equipment Category	
3G, 3D	
Equipment Protection Level	
Gc, Dc	
Maximum Surface Temperature for Dust Applications	
95°C DC Models 93°C AC Models	
Ambient Temperature Range	
-55°C to +75°C (-67°F to +167°F)	
IP Rating	
IP66/67 to EN60529 4 / 4X / 3R / 13 to UL50E / NEMA250	
Installation must be carried out in compliance with the latest issue of the following standards:	
EN60079-14 / IEC60079-14: Explosive atmospheres - Electrical installations design, selection and erection	
EN60079-10-1 / IEC60079-10-1: Explosive atmospheres - Classification of areas. Explosive gas atmospheres	
EN60079-10-2 / IEC60079-10-2: Explosive atmospheres - Classification of areas. Explosive dust atmospheres	

5) Special Conditions of Safe Use

Special Condition for safe Use as stated on the Type Examination Certificate 06ATEX 0421554X / CoC IECEx ULD 14.0012X:

End user shall adhere to the manufacturer's installation and instruction when performing housekeeping to avoid the potential for hazardous electrostatic charge during cleaning, by using a damp cloth.

To maintain the ingress protection rating and mode of protection, the cable entries must be fitted with suitably rated, certified cable entry and/or blanking devices during installation.

Equipment with the flare horn shall not be installed with the flare higher than horizontal (to avoid accumulation of dust).

6) Product Mounting and Access

6.1 Mounting

The D2xS2 Alarm Horn may be secured to any flat surface using at least two of the three or four 7mm fixing holes. The enclosure provides IP66 protection and is suitable for installation in exterior locations providing it is positioned so that water cannot collect in the horn, and the cable entry is sealed.

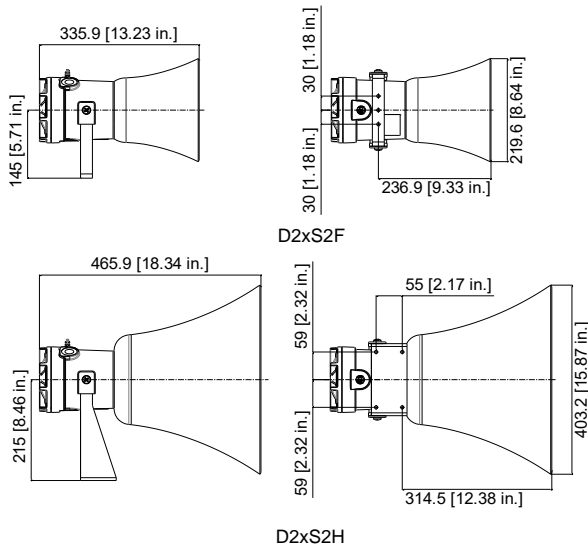
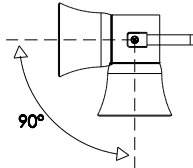

Fig 1: Mounting Locations

The Equipment must not be installed with the horn facing upwards of horizontal.



6.2 Installation procedure

- Secure the D2xS2 unit to a flat surface via the three 7mm fixing holes in the mounting bracket.
- Remove the cover of the alarm horn by unscrewing it, taking care not to damage the threads in the process (Refer to section 6.3).
- Fit an M20/NPT suitably rated cable gland or conduit entry into the hole in the enclosure and connect the field wiring to the appropriate alarm horn terminals as shown in D252-06-005 (AC) or D252-06-001. (DC). The power supply terminals are duplicated so that units may be connected in parallel. An end of line monitoring resistor may be fitted to DC units only (see section 9). If the second and third M20/NPT entries are not used, suitably rated stopping plugs must always be fitted.
- Replace the cover of the unit, taking care not to damage the threads. Tighten fully.

6.3 Access to the Enclosure

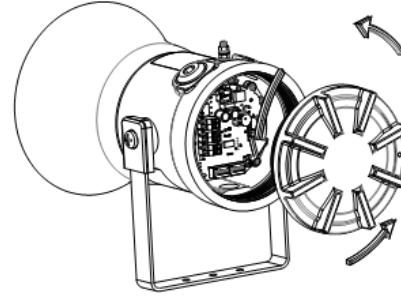

Fig 2: Accessing the enclosure

To access the chamber, loosen the M4 grub screw on the sounder cover. Open the enclosure by turning the sounder cover counterclockwise and remove the cover. Take extreme care not to damage the threads in the process.

On completion of the installation the threaded joint should be inspected to ensure that they are clean and that they have not been damaged during installation.

Ensure the O-ring seal is in place and undamaged.

When fitting the cover ensure the thread is engaged correctly. Fully tighten the cover all the way, ensure no gap is visible between the cover and base of the sounder enclosure.

7) Installation Requirements

7.1 Safe Installation Requirements



Warning – High voltage may be present, risk of electric shock. DO NOT open when energised, disconnect power before opening.

The sounder must only be installed by suitably qualified personnel in accordance with the latest issues of the relevant standards.

The installation of the units must also be in accordance with the NEC / CEC and any local regulations and should only be carried out by a competent electrical engineer who has the necessary training.

7.2 Cable Selection and Connections

Electrical connections are to be made into the terminal blocks on the PCBA, using solid wire 0.5-4mm² / AWG 20-12 or stranded wire, sizes 0.5-2.5mm² / AWG 24-14. Wire insulation needs to be stripped 8mm. Wires may be fitted securely with crimped ferrules. Terminal screws need to be tightened down with a tightening torque of 0.45 Nm / 3.5 Lb-in.

When selecting the cable size, consideration must be given to the input current that each unit draws (see table 1), the number of sounders on the line and the length of the cable runs. The cable size selected must have the necessary capacity to provide the input current to all the sounders connected to the line.

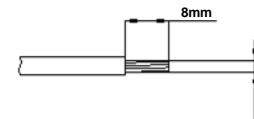

Solid Wire: 0.5 - 4mm² / AWG20 - AWG12
Stranded Wire: 0.5 - 2.5mm² / AWG24 - AWG14

Fig 3: Wire Preparation.

When connecting wires to the terminals great care should be taken to dress the wires so that when the cover is inserted into the chamber the wires do not exert excess pressure on the terminal blocks. This is particularly important when using cables with large cross-sectional areas such as 2.5mm².

7.3 Earthing

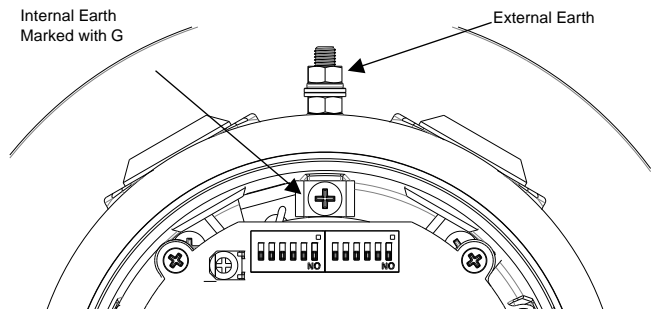

Fig. 4 Earth Locations

Please note that for AC supply voltage product versions the Earth terminal on the PCBA does not provide an earth connection to the product enclosure. The enclosure must be independently earthed using either the external or internal earth fixing point, (see fig 4 and notes below).

The unit has both a primary internal and secondary external earth fixing point.

Internal earthing connections should be made to the Internal Earth terminal in the base of the housing using a ring crimp terminal to secure the earth conductor under the earth clamp. The earth conductor should be at least equal in size and rating to the incoming power conductors but at least a minimum of 0.82mm² / 18AWG in size.

External earth connections can be made to the M5 earth stud (see Fig. 4), using a ring crimp terminal to secure the earth conductor to the earth stud. The external earth conductor should be at least 4mm² in size.

The external earth crimp ring should be located between the two M5 plain washers provided and securely locked down with the M5 spring washer and M5 nut.

7.4 Cable Glands, Blanking Elements & Adapters

Ingress Protection

If a high IP (Ingress Protection) rating is required then a suitable sealing washer must be fitted under the cable glands or blanking plugs. A minimum ingress protection rating of IP54 must be maintained for installations in explosive gas atmospheres and IP6X must be maintained for installations in explosive dust atmospheres.

To maintain the ingress protection rating and mode of protection, the cable entries must be fitted with suitably rated cable entry and/or blanking devices during installation.

If entries are fitted with adaptors they must be suitably rated for the application. Fitting of blanking elements into adaptors is not permitted.

Adapters

The D2xS2 sounder range can be supplied with the following types of adapters:

- M20 to 1/2" NPT
- M20 to 3/4" NPT
- M20 to M25

It is important to note that stopping plugs cannot be fitted onto adapters, only directly onto the M20 entries.

80°C and therefore suitable heat resisting cables and cable glands must be used, with a rated service temperature at least as stated below:

Ambient Temp. (°C)	55	60	65	70	75
D2xS2FDC024 / D2xS2HDC024	-	70	75	80	85
Min. Rating of cables and cable glands (°C)					
D2xS2FAC230 / D2xS2HAC230	70	75	80	85	90
Min. Rating of cables and cable glands (°C)					

8) Settings

Following illustrations show the settings available for D2xS2 Alarm Horn Sounders. See schematic diagram D252-06-001 for details.

8.1 Configuration

See Table 1 for product power supply and Sound Pressure Levels (SPL).

Configuration for DC Units

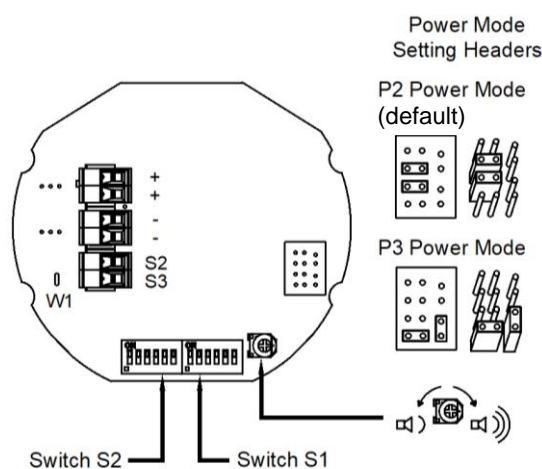

Fig 5: DC PCBA.

Configuration for AC Units

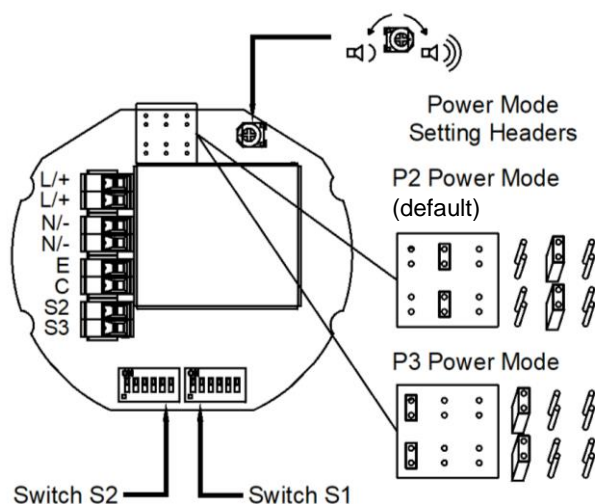

Fig 6: AC PCBA .

8.2 Stage Switching Polarity (DC Units)

For high ambient temperatures the cable entry temperature may exceed 70°C or the cable branching point temperature may exceed

Switching from positive switching (default) to negative switching - DC Only.

NOTE: Max supply is 33V DC – if higher DC voltage is required, use Negative switching.

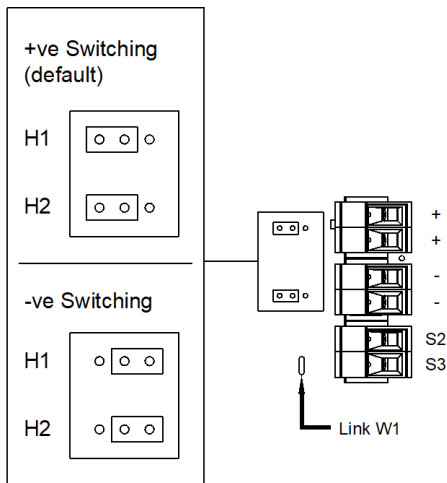

Fig 7: Stage Switching Polarity.

8.3 Tone Selection

The D2xS2 Alarm Horn Sounders have 64 different tones that can be selected independently for the first and second stage alarms. The tones are selected by operation of the tone setting DIP switch 1 & DIP switch 2 (see fig 8) on the PCB, for stage 1 and stage 2 respectively.

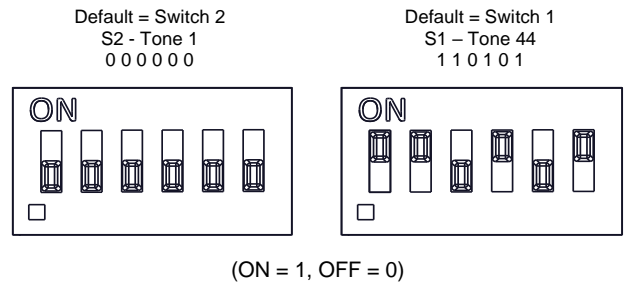

Figure 8: DIP switch configuration

The sounder can also be switched to sound the third and fourth stage alarm tones.

The tone table (D221-95-001-IS) shows the switch positions for the 64 tones on first and second stages and which tones are available for the third and fourth stages dependent on the Stage 1 DIP switch setting.

Following table (Table 3) is a summary of DC: D252-06-001; AC: D252-06-005 wiring options.

Config.	Voltage	Configuration Description	Features	Product Option Identifier
1a	DC	Single Stage Configuration	<ul style="list-style-type: none"> Line monitoring Positive Switching 	1
1b	DC	Two Stage Configuration	<ul style="list-style-type: none"> Common Negative Positive Switching 	1
1c	DC	Three/Four Stage Configuration	<ul style="list-style-type: none"> Common Negative Positive Switching 	1
2	DC	Three/Four Stages. Voltage Free 2nd, 3rd & 4th Stage Activation Configuration	<ul style="list-style-type: none"> Common Positive Customer Set H1 & H2 to Negative Switching 	1
3	DC	Two Stage Configuration	<ul style="list-style-type: none"> Independent Stage Input Reverse Polarity Stage Monitoring 	1
4	DC	Two Stage Configuration	<ul style="list-style-type: none"> Line Stage Monitoring (Use suitable monitoring relays/ modules) Not to be used in reverse polarity monitoring 	Y
5	DC	Two/Three Stage Voltage Free Activation Configuration		K
6	DC	Three/Four Stage Configuration	<ul style="list-style-type: none"> Independent Stage Input Line Stage Monitoring (Use suitable monitoring relays/ modules) Positive Switching (Default) 	V
1a	AC	Single Stage Configuration		1
1b	AC	Three/Four Stage Configuration		1
2	AC	Two/Three Stage Voltage Free Activation Configuration		K

Table 3: Summary of Wiring Options. See Document D252-06-001 for DC Schematic Diagrams; D252-06-005 for AC Schematic Diagrams.

9) End of Line Monitoring (DC Units)

9.1 Standard DC End Of Line Monitoring

On D2xS2 DC units, DC reverse line monitoring can be used if required. All DC sounders have a blocking diode fitted in their supply input lines. An end of line monitoring resistor can be connected across the +ve and -ve terminals. If an end of line resistor is used it must have the following values:

24V DC Max Sounder
 Minimum resistance 3K9 Ohms Minimum Power 0.5W
 Minimum resistance 1K Ohms Minimum Power 2.0W

48V DC Max Sounders
 Minimum resistance 15K Ohms Minimum Power 0.5W
 Minimum resistance 3K9 Ohms Minimum Power 2.0W

The resistor must be connected directly across the +ve and -ve terminals as shown in the following drawing. Whilst keeping its leads as short as possible, a spacing of at least 1/16" (1.58mm) must be provided through air and over surfaces between uninsulated live parts. See D252-06-001 for details.

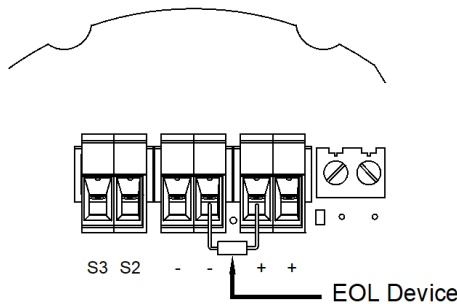

Figure 9: End of Line Resistor placement.

Note that the maximum forward polarity monitoring voltage is 6V. A monitoring voltage greater than 6V may activate the alarm horn sounder and the 2nd, 3rd or 4th stages.

9.2 Custom DC Multi-Stage End Of Line Monitoring

An optional 12-way terminal module is available to enable up to four alarm stages to be activated from three DC voltage output channels. The three alarm stage activation inputs can be independently monitored.

Refer to Schematic D252-06-001, Config. 6.
 Specify Product option 'V' when ordering.
 Spare part code for field installation: SP78-0001

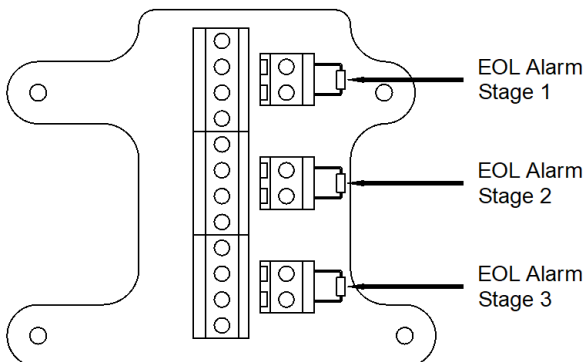

Figure 10: End of Line Resistor placement – Optional 12-Way Terminal Module.

10) Maintenance, Overhaul and Repair

Maintenance, repair and overhaul of the equipment should only be carried out by suitably qualified personnel in accordance with the current relevant standards:

For ATEX/IECEX or UKEx:

EN60079-19/IEC60079-19
 Explosive atmospheres – Equipment repair, overhaul and reclamation

EN 60079-17/IEC60079-17
 Explosive atmospheres – Electrical installations inspection and maintenance

Units must not be opened while an explosive atmosphere is present.

If opening the unit during maintenance operations, a clean environment must be maintained and any dust layer removed prior to opening the unit.

To avoid a possible ELECTROSTATIC CHARGE the unit must only be cleaned with a damp cloth.

11) SIL 2 Reliability Data

Reliability and Functional safety IEC/EN61508 which has been assessed and is considered suitable for use in low demand safety function:

1. Random Hardware Failures and Architectural constraints (route 2_H).
2. As an unvoted item (i.e. hardware fault tolerance of 0) at SIL 2. The product was assessed against failure modes:
 - Failure respond to an input by sounding sounder.
 - Spurious sound output despite no input.
3. When employing the device in a SIL2 compliant system the user should ensure frequent or continuous automatic monitoring of continuity.

Integrity in respect of failure to function	SIL2 & SIL1
Total Failure rate	0.55 pmh
"Hazardous" failure rate (revealed)	0 pmh
"Hazardous" failure rate (unrevealed)	0.55 pmh
"Safe" failure rate (revealed)	0 pmh
"Safe" failure rate (unrevealed)	0
System type	B
Hardware Fault Tolerance	0
Diagnostic Coverage	>80%
PFD (hazardous failure)	2.4×10^{-3}
Proof Test Interval	Up to 1 year



All models are approved for use as Audible Signal Appliance for use as General Signaling: UL464A & CSA C22.2 No 205-17

- Type 4 / 4X / 3R / 13, IP66
- -55°C to +85°C / -67°C to +176°F
General Signaling Canada:
D2xS2-AC230-A: -55°C to +40°C / -67°F to +104°F
D2xS2-DC024-A: -55°C to +85°C / -67°F to +185°F
- To maintain Ingress Protection, cable entries must be fitted with suitably rated cable glands or stopping plugs
- EOL Monitoring (DC Only): End of Line Devices may be fitted between the +ve & -ve terminals of the PCBA. Please ensure that the device legs meet the wire size range stated for the connection terminals and are fitted correctly in order to avoid a short. Refer to the compatible control panel specification for EOL device values and ratings

Model	Nominal Voltage	Voltage Range	P2 Nominal Operating Current [#]	P3 Nominal Operating Current [#]	P2 Max Operating RMS [*]	P3 Max Operating RMS [*]
D2xS2-DC024-A	12V dc	11.5 - 54V dc	289mA	356mA	324mA	740mA
	24V dc		324mA	740mA		
	48V dc		195mA	391mA		
D2xS2-AC230-A	115V ac	100- 240V ac 50/60Hz	125mA	282mA	194mA	480mA
	230V ac		78mA	167mA		



Attention: Installation must be carried out by an electrician in compliance with the National Electrical Code, NFPA 70, and the National Fire Alarm Signaling Code, NFPA 72 or CSA 22.1 Canadian Electrical Code, Part I, Safety Standard for Electrical Installations, Section 32. / L'installation doit exclusivement être réalisée par du personnel qualifié, conformément au code national d'électricité américain, NFPA 70, et le code national d'alarme incendie et de signalisation NFPA 72 ou CSA 22.1 Code canadien de l'électricité, première partie, norme de sécurité relative aux installations électriques, Section 32



Attention: Disconnect from power source before installation or service to prevent electric shock / Débranchez-le de la source d'alimentation avant l'installation ou l'entretien pour éviter tout choc électrique.



Attention: Fire Alarm Device—Do not paint / Ne pas Peinturer—Dispositif D'Alarme



Attention: Do not change factory applied finishes / Ne pas changer le revêtement applique en usine

- Type 4 / 4X / 3R / 13, IP66
- -55°C to +80°C / -67°F to +176°F
- Units should be mounted using at least 2 of the 3-off/4-off ø7mm holes in the mounting bracket.
- The Equipment must not be installed with the horn facing upwards of horizontal.
- D2xS2FDC024-A is approved for use as an audible signal appliance for fire alarm use – Public Mode (UL464 & CAN/ULC-S525) and produces a minimum sound pressure level of P2: US: 94.9dB(A); CA: 101.6dB(A) / P3: US: 96.96dB(A); CA: 103.6dB(A) at 10 feet, (figures @ worst case voltage 11.5V).
- D2xS2FDC024-A is approved for use as an audible signal appliance for fire alarm use – Public Mode (UL464 & CAN/ULC-S525) and produces a minimum sound pressure level of P2: US: 98.42dB(A); CA: 105.2dB(A) / P3: US: 104.11dB(A); CA: 110.6dB(A) at 10 feet, (figures @ 24V).
- D2xS2HDC024-A is approved for use as an audible signal appliance for fire alarm use – Public Mode (UL464 & CAN/ULC-S525) and produces a minimum sound pressure level of P2: US: 95.51dB(A); CA: 103.8dB(A) / P3: US: 97.11dB(A); CA: 107.9dB(A) at 10 feet, (figures @ worst case voltage 11.5V).
- D2xS2HDC024-A is approved for use as an audible signal appliance for fire alarm use – Public Mode (UL464 & CAN/ULC-S525) and produces a minimum sound pressure level of P2: US: 100.2dB(A); CA: 108.5dB(A) / P3: US: 104.02dB(A); CA: 114.9dB(A) at 10 feet, (figures @ 24V).
- If a high IP (Ingress Protection) rating is required then a suitable sealing washer or O-ring must be fitted under any cable gland or blanking device with metric threads.
- To maintain the enclosure rating, the cable entries must be fitted with suitably rated cable entry and/or blanking devices or suitably sized conduit during installation. If entries are fitted with adaptors they must be suitable for the application.
- Units can be located indoor or outdoor wet use, wall or ceiling mounted and there are no limitations on orientation.
- For Fire Alarm applications, the Sounder Volume must be at the highest setting, (see volume control section). For fire alarm use, Tone 12 as shown below must be selected:

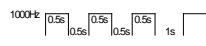
Stage 1 Set DIP SW 1 Tone No.	Tone Description	Tone Visual	Stage 1 & 2 DIP SW 1/2 Settings 1 2 3 4 5 6	Stage 3 Set DIP SW 1 (S3)	Stage 4 Set DIP SW 1 (S2 + S3)
12	1000Hz(0.5s on, 0.5s off)x3 + 1s gap ISO 8201 Temporal Pattern		1 1 0 1 0 0	1	8

- Connection Terminals: Pluggable, 0.2 - 2.5mm² / AWG24 - AWG12
- Terminal Tightening torque 0.4Nm/3.5lb-in.

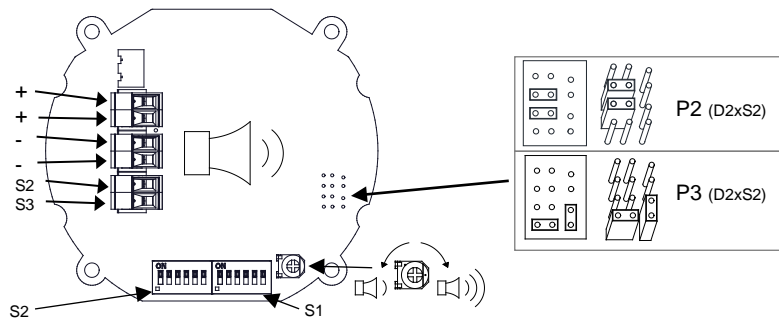

OSPL	Horizontal Axis	Vertical Axis
-3dB(A)	+16.3° / -10°	+/-10°
-6dB(A)	+40° / -13.3°	+/-15°

OSPL	Horizontal Axis	Vertical Axis
-3dB(A)	+/-10°	+/-10°
-6dB(A)	+/-15°	+/-35°

Model	Nominal Voltage	Voltage Range	Initial Peak	Initial RMS	Repetitive Peak	Repetitive RMS	Operating RMS
D2xS2FDC024-A D2xS2HDC024-A	24V dc	11.5 - 54V dc	P3:1910 mA	P3:922 mA	P3: 625 mA	P3:522 mA	P3:603 mA

Stage 1 Set DIP SW 1 Tone No.	Tone Description	Tone Visual	Stage 1 & 2 DIP SW 1/2 Settings 1 2 3 4 5 6	Stage 3 Set DIP SW 1 (S3)	Stage 4 Set DIP SW 1 (S2 + S3)
1	1000Hz PFEER Toxic Gas		0 0 0 0 0	2	44
2	1200/500Hz @ 1Hz DIN /PFEER P.T.A.P.		1 0 0 0 0	3	44
3	1000Hz @ 0.5Hz(1s on, 1soff) PFEER Gen. Alarm		0 1 0 0 0 0	2	44
4	1.4KHz-1.6KHz 1s, 1.6KHz-1.4KHz 0.5s NF C 48-265		1 1 0 0 0 0	24	1
5	544Hz(100mS)/440Hz (400mS) NF S 32-001		0 0 1 0 0 0	19	1
6	1500/500Hz - (0.5s on , 0.5s off) x3 + 1s gap AS4428		1 0 1 0 0 0	44	1
7	500-1500Hz Sweeping 2 sec on 1 sec off AS4428		0 1 1 0 0 0	44	1
8	500/1200Hz @ 0.26Hz (3.3son, 0.5s off) Netherlands - NEN 2575		1 1 1 0 0 0	24	35
9	1000Hz (1s on, 1s off)x7 + (7s on, 1s off) IMO Code 1a		0 0 0 1 0 0	34	1
10	1000Hz (1s on, 1s off)x7 + (7s on, 1s off) IMO Code 1a		1 0 0 1 0 0	34	1
11	420Hz(0.5s on, 0.5s off)x3 + 1s gap ISO 8201 Temporal Pattern		0 1 0 1 0 0	1	8
12	1000Hz(0.5s on, 0.5s off)x3 + 1s gap ISO 8201 Temporal Pattern		1 1 0 1 0 0	1	8
13	422/775Hz - (0.85 on, 0.5 off) x3 + 1s gap NFPA - Temporal Coded		0 0 1 1 0 0	1	8
14	1000/2000Hz @ 1Hz Singapore		1 0 1 1 0 0	3	35
15	300Hz Continuous (f=300)		0 1 1 1 0 0	24	35
16	440Hz Continuous (f=440)		1 1 1 1 0 0	24	35
17	470Hz Continuous (f=470)		0 0 0 0 1 0	24	35
18	500Hz Continuous IMO code 2 (Low) (f=500)		1 0 0 0 1 0	24	35
19	554Hz Continuous (f=554)		0 1 0 0 1 0	24	35
20	660Hz Continuous (f=660)		1 1 0 0 1 0	24	35
21	800Hz IMO code 2 (High) (f=800)		0 0 1 0 1 0	24	35
22	1200Hz Continuous (f=1200)		1 0 1 0 1 0	24	35
23	2000Hz Continuous (f=2000)		0 1 1 0 1 0	3	35
24	2400Hz Continuous (f=2400)		1 1 1 0 1 0	20	35
25	440Hz @0.83Hz (50 cycles/minute) Intermittent (f=440, a=0.6, b=0.6)		0 0 0 1 1 0	44	8
26	470Hz @0.9Hz - 1.1s Intermittent (f=470, a=0.55, b=0.55)		1 0 0 1 1 0	44	8
27	470Hz @5Hz - (5 cycles/second) Intermittent (f=470, a=0.1, b=0.1)		0 1 0 1 1 0	44	8
28	544Hz @ 1.14Hz - 0.875s Intermittent (f=470, a=0.43, b=0.44)		1 1 0 1 1 0	24	8
29	655Hz @ 0.875Hz Intermittent (f=655, a=0.57, b=0.57)		0 0 1 1 1 0	44	8
30	660Hz @0.28Hz - 1.8sec on, 1.8sec off Intermittent (f=660, a=1.8, b=1.8)		1 0 1 1 1 0	24	8
31	660Hz @3.34Hz - 150mS on, 150mS off Intermittent (f=660, a=0.15, b=0.15)		0 1 1 1 1 0	24	8
32	745Hz @ 1Hz Intermittent (f=745, a=0.5, b=0.5)		1 1 1 1 1 0	24	8
33	800Hz - 0.25sec on, 1 sec off Intermittent (f=800, a=0.25, b=1)		0 0 0 0 0 1	24	8
34	800Hz @ 2Hz IMO code 3.a (High) Intermittent (f=800, a=0.25, b=0.25)		1 0 0 0 0 1	24	8
35	1000Hz @ 1Hz Intermittent (f=1000, a=0.5, b=0.5)		0 1 0 0 0 1	24	8
36	2400Hz @ 1Hz Intermittent (f=2400, a=0.5, b=0.5)		1 1 0 0 0 1	24	8
37	2900Hz @ 5Hz Intermittent (f=2900, a=0.1, b=0.1)		0 0 1 0 0 1	24	8
38	363/518Hz @ 1Hz Alternating (f=363, f1=518, a=0.1)		1 0 1 0 0 1	8	19
39	450/500Hz @ 2Hz Alternating (f=450, f1=500, a=0.25)		0 1 1 0 0 1	8	19
40	554/440Hz @ 1Hz Alternating (f=440, f1=554, a=0.5)		1 1 1 0 0 1	24	19
41	554/440Hz @ 0.625Hz Alternating (f=440, f1=554, a=0.8)		0 0 0 1 0 1	8	19
42	561/760Hz @0.83Hz (50 cycles/minute) Alternating (f=561, f1=760, a=0.6)		1 0 0 1 0 1	8	19
43	780/600Hz @ 0.96Hz Alternating (f=600, f1=780, a=0.52)		0 1 0 1 0 1	8	19
44	800/1000Hz @ 2Hz Alternating (f=800, f1=1000, a=0.25)		1 1 0 1 0 1	24	19
45	970/800Hz @ 2Hz Alternating (f=800, f1=970, a=0.25)		0 0 1 1 0 1	8	19
46	800/1000Hz @ 0.875Hz Alternating (f=800, f1=1000, a=0.57)		1 0 1 1 0 1	24	19
47	2400/2900Hz @ 2Hz Alternating (f=2400, f1=2900, a=0.25)		0 1 1 1 0 1	24	19
48	500/1200Hz @ 0.3Hz Sweeping (f=500, f1=1200, a=3.34)		1 1 1 1 0 1	24	12
49	560/1055Hz @ 0.18Hz Sweeping (f=560, f1=1055, a=5.47)		0 0 0 0 1 1	24	12
50	560/1055Hz @ 3.3Hz Sweeping (f=560, f1=1055, a=0.3)		1 0 0 0 1 1	24	12
51	600/1250Hz @ 0.125Hz Sweeping (f=600, f1=1250, a=8)		0 1 0 0 1 1	24	12
52	660/1200Hz @ 1Hz Sweeping (f=660, f1=1200, a=1)		1 1 0 0 1 1	24	12
53	800/1000Hz @ 1Hz Sweeping (f=800, f1=1000, a=1)		0 0 1 0 1 1	24	12
54	800/1000Hz @ 7Hz Sweeping (f=800, f1=1000, a=0.14)		1 0 1 0 1 1	24	12
55	800/1000Hz @ 50Hz Sweeping (f=800, f1=1000, a=0.02)		0 1 1 0 1 1	24	12
56	2400/2900Hz @ 7Hz Sweeping (f=2400, f1=2900, a=0.14)		1 1 1 0 1 1	24	12
57	2400/2900Hz @ 1Hz Sweeping (f=2400, f1=2900, a=1)		0 0 0 1 1 1	24	12
58	2400/2900Hz @ 50Hz Sweeping (f=2400, f1=2900, a=0.02)		1 0 0 1 1 1	24	12
59	2500/3000Hz @ 2Hz Sweeping (f=2500, f1=3000, a=0.5)		0 1 0 1 1 1	24	12
60	2500/3000Hz @ 7.7Hz Sweeping (f=2500, f1=3000, a=0.13)		1 1 0 1 1 1	24	12
61	800Hz Motor Siren (f=800, a=1.6)		0 0 1 1 1 1	24	12
62	1200Hz Motor Siren (f=1200, a=2)		1 0 1 1 1 1	24	12
63	2400Hz Motor Siren (f=2400, a=1.7)		0 1 1 1 1 1	24	12
64	Simulated Bell		1 1 1 1 1 1	21	12

1	2	3	4	5	6	7	8	9	10
							ISSUE	MOD No.	REASON - INITIAL - DATE
							1		INTRODUCTION RSR - 06/09/2023
							2		AMENDED EOL VALUES RSR - 13/10/2023

OPTIONAL LINE MONITORING RESISTOR, CUSTOMER SUPPLIED,
RECOMMENDED MINIMUM VALUES:
24V MAX SYSTEM = 3K9Ω MIN, 0.5W MIN OR 1KΩ MIN, 2.0W MIN
48V MAX SYSTEM = 15KΩ MIN, 0.5W MIN OR 3K9Ω MIN, 2.0W MIN

Single Stage Configuration	Config.: 1a	Two Stage Configuration	Config.: 1b	Three/Four Stage Configuration	Config.: 1c
Line Monitoring Set to positive switching (default)		Common Negative Set to positive switching (default)		Common Negative Set to positive switching (default)	
Stage 1: Apply Power to Stage 1 +ve & Stage 1 -ve		Stage 1: Apply Power to Stage 1 +ve & Common -ve Stage 2: Apply Power to Stage 2 +ve & Common -ve		Stage 1: Apply Power to Stage 1 +ve & Common -ve Stage 2: Apply Power to Stage 2 +ve & Common -ve Stage 3: Apply Power to Stage 3 +ve & Common -ve Stage 4: Apply Power to Stage 2 +ve, Stage 3 +ve & Common -ve	

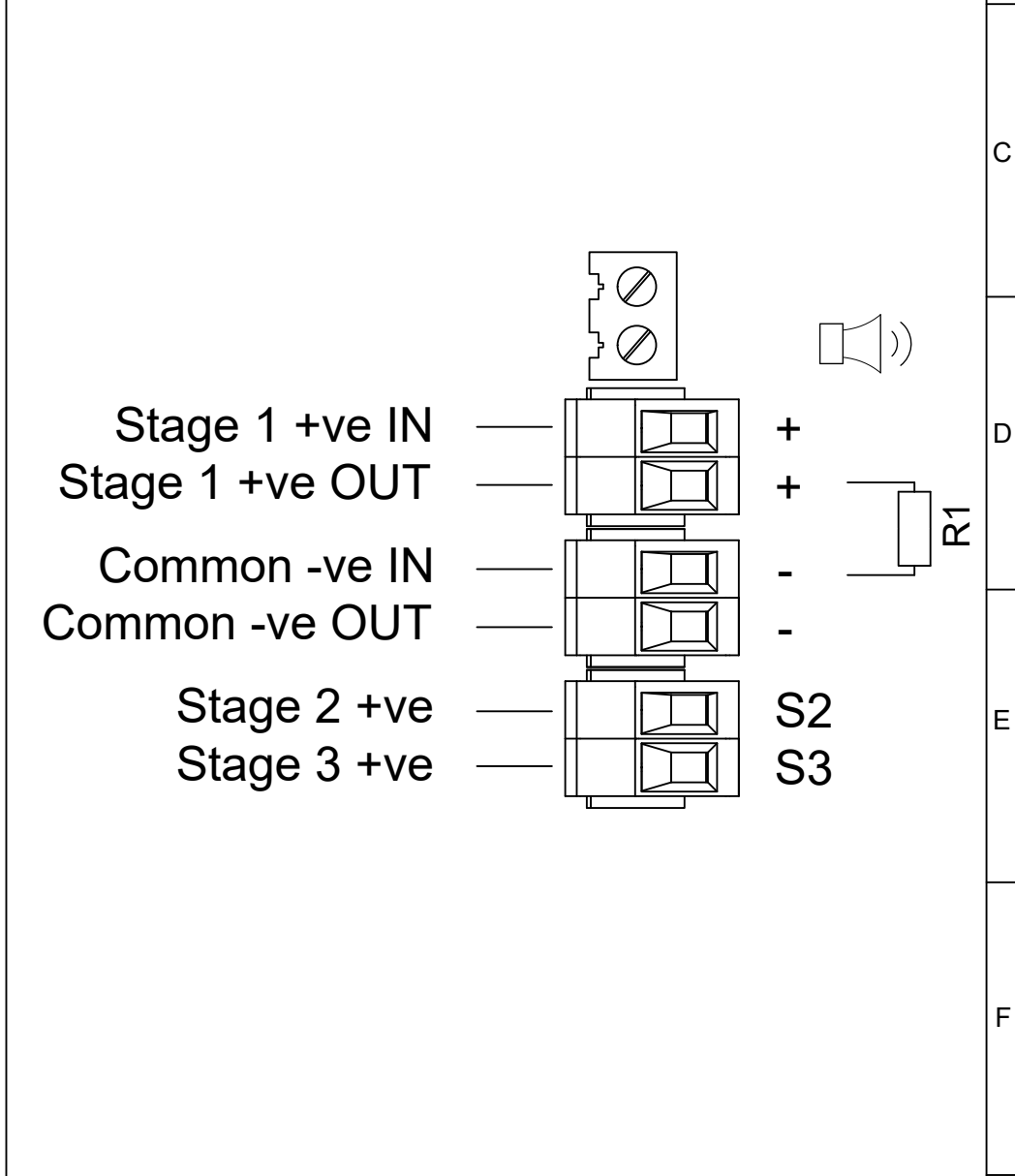
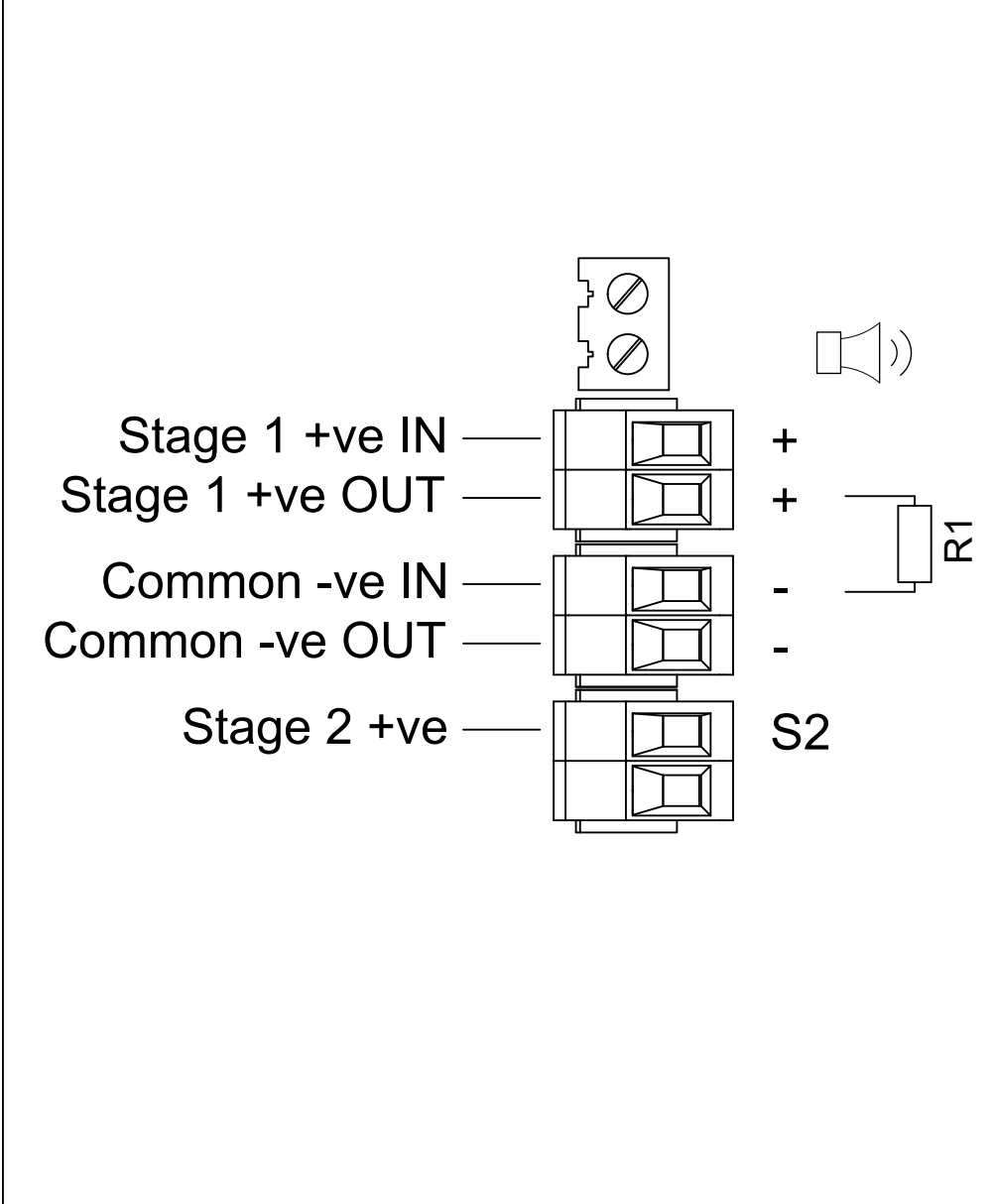
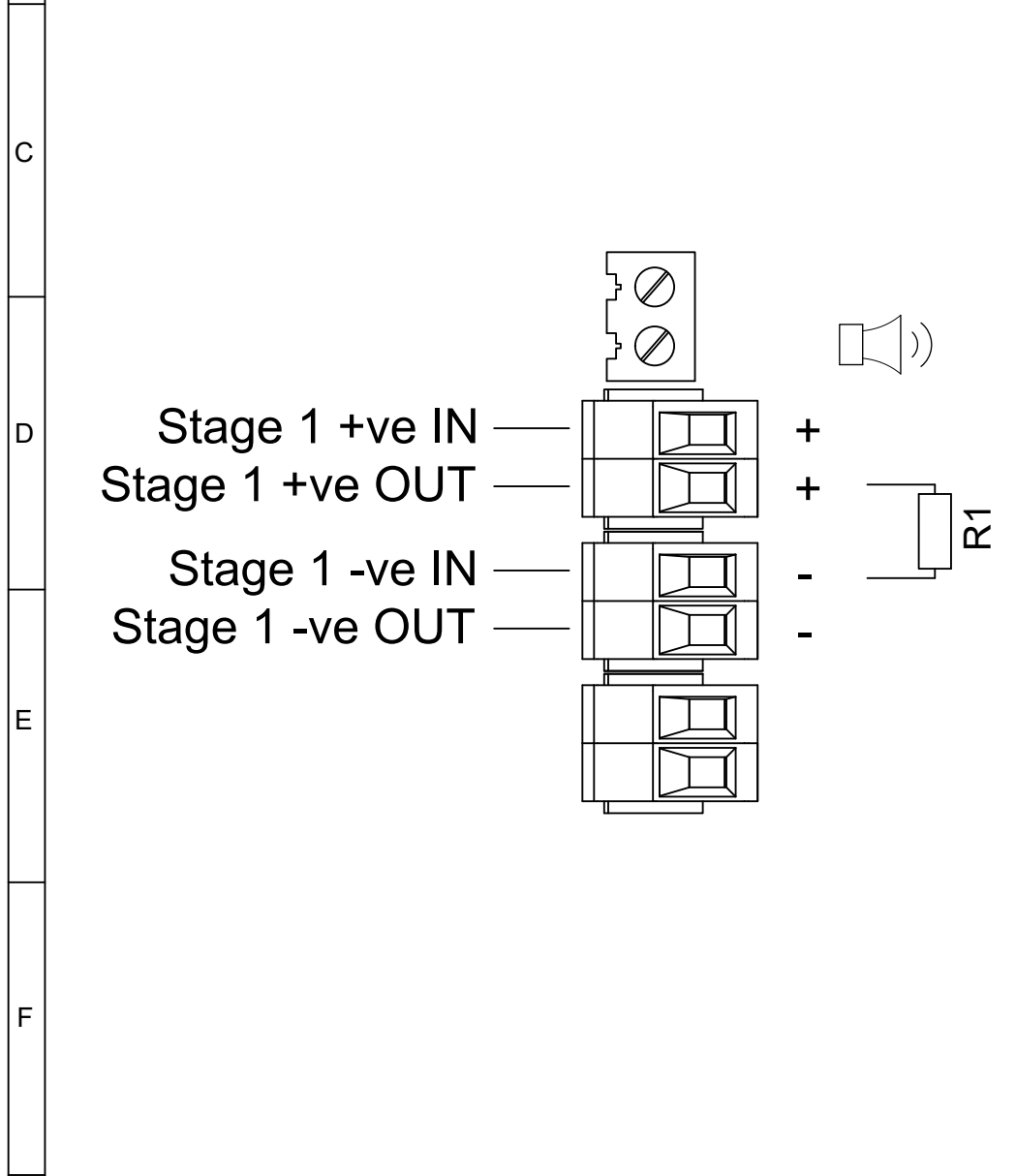

DRAWING TO BS8888:2000 GEOMETRIC TOLERANCES TO ISO1101:1983 LINEAR DIMENSIONAL TOLS ANGULAR DIMENSIONAL TOLS	DRAWN	DATE	SURFACE FINISH	WEIGHT (Kg)	THIS DRAWING AND ANY INFORMATION OR DESCRIPTIVE MATTER THEREIN IS COMMUNICATED IN CONFIDENCE AND IS THE COPYRIGHT PROPERTY OF EUROPEAN SAFETY SYSTEMS LTD. NEITHER THE WHOLE OR ANY EXTRACT MAY BE DISCLOSED, LOANED, COPIED OR USED FOR MANUFACTURING OR TENDERING PURPOSES WITHOUT THEIR WRITTEN CONSENT.	 EUROPEAN SAFETY SYSTEMS LTD IMPRESS HOUSE MANSELL ROAD ACTON LONDON W3 7QH WWW.E2S.COM	ALL DIMENSIONS IN MM			A3
	R.S.RAIT	19/01/2022					MATERIAL			
	CHECKED	DATE	ALTERNATIVE MATERIAL				SCALE	SHEET	DRAWING NUMBER	
	B.ISARD	19/01/2022					NTS	1 OF 3	D252-06-001	
STANDARDS	APPROVED	DATE								
D2x	R.N.POTTS	19/01/2022								

1	2	3	4	5	6	7	8	9	10
							ISSUE	MOD No.	REASON - INITIAL - DATE
							1		INTRODUCTION RSR - 06/09/2023
							2		AMENDED EOL VALUES RSR - 13/10/2023

OPTIONAL LINE MONITORING RESISTOR, CUSTOMER SUPPLIED,
RECOMMENDED MINIMUM VALUES:
24V MAX SYSTEM = 3K9Ω MIN, 0.5W MIN OR 1KΩ MIN, 2.0W MIN
48V MAX SYSTEM = 15KΩ MIN, 0.5W MIN OR 3K9Ω MIN, 2.0W MIN

SWITCHES FOR STAGE OPERATION
CUSTOMER SUPPLIED

Three/Four Stages. Voltage Free 2nd, 3rd & 4th Stage Activation Configuration				Config.: 2	Two Stage Configuration				Config.: 3
Common Positive Customer Set H1 & H2 to Negative Switching (See Below)				Independent Stage Input Reverse Polarity Stage Monitoring					
Stage 1: Apply Power to Common +ve & Stage 1 -ve Stage 2: Apply Power to Common +ve & Stage 1 -ve & connect Stage 2 -ve to Stage 1 -ve Stage 3: Apply Power to Common +ve & Stage 1 -ve & connect Stage 3 -ve to Stage 1 -ve Stage 4: Apply Power to Common +ve & Stage 1 -ve & connect Stage 2 -ve & Stage 3 -ve to Stage 1 -ve				Stage 1: Apply Power to Stage 1 +ve & Stage 1 -ve Stage 2: Apply Power to Stage 1 +ve & Stage 1 -ve & connect Stage 2 -ve to Stage 1 -ve					

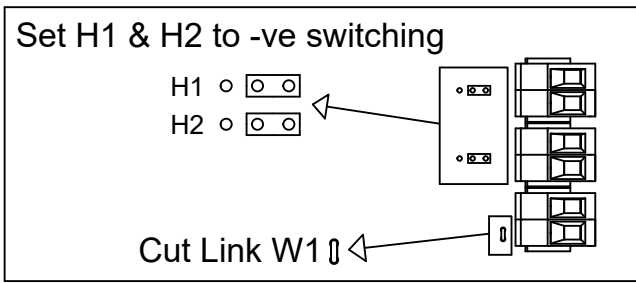
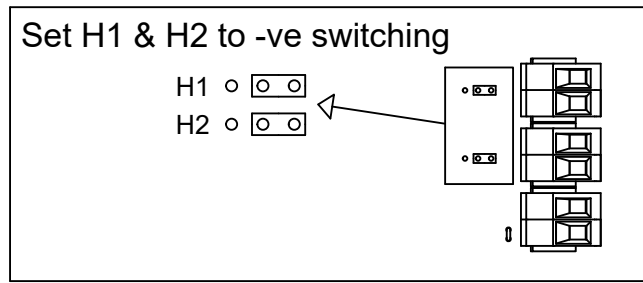
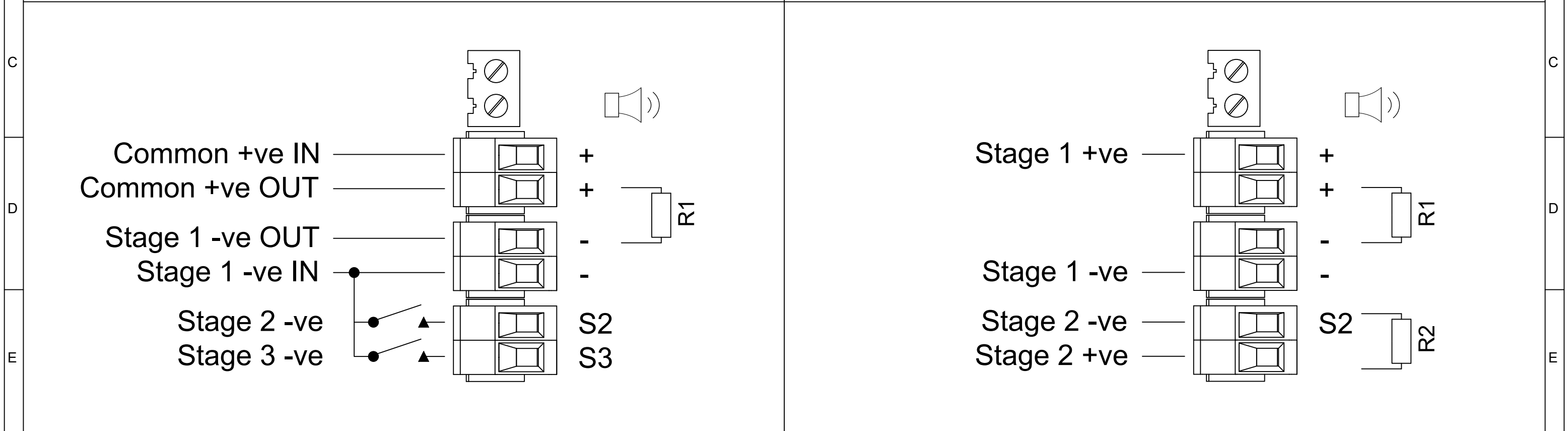

DRAWING TO BS8888:2000 GEOMETRIC TOLERANCES TO ISO1101:1983 LINEAR DIMENSIONAL TOLS ANGULAR DIMENSIONAL TOLS	DRAWN	DATE	SURFACE FINISH	WEIGHT (Kg)	THIS DRAWING AND ANY INFORMATION OR DESCRIPTIVE MATTER THEREIN IS COMMUNICATED IN CONFIDENCE AND IS THE COPYRIGHT PROPERTY OF EUROPEAN SAFETY SYSTEMS LTD. NEITHER THE WHOLE OR ANY EXTRACT MAY BE DISCLOSED, LOANED, COPIED OR USED FOR MANUFACTURING OR TENDERING PURPOSES WITHOUT THEIR WRITTEN CONSENT.	 EUROPEAN SAFETY SYSTEMS LTD IMPRESS HOUSE MANSELL ROAD ACTON LONDON W3 7QH WWW.E2S.COM	ALL DIMENSIONS IN MM			A3
	R.S.RAIT	19/01/2022	MATERIAL				IF IN DOUBT, ASK - DO NOT SCALE			
	CHECKED	DATE	ALTERNATIVE MATERIAL				SCALE	SHEET	DRAWING NUMBER	
	B.ISARD	19/01/2022					NTS	2 OF 3	D252-06-001	
STANDARDS	APPROVED	DATE			EUROPEAN SAFETY SYSTEMS LTD. AS PER LATEST DATE OF ISSUE SHOWN ABOVE					
D2x	R.N.POTTS	19/01/2022								

1	2	3	4	5	6	7	8	9	10
							ISSUE	MOD No.	REASON - INITIAL - DATE
							1		INTRODUCTION RSR - 06/09/2023
							2		AMENDED EOL VALUES RSR - 13/10/2023

OPTIONAL LINE MONITORING RESISTOR, CUSTOMER SUPPLIED,
RECOMMENDED MINIMUM VALUES:
24V MAX SYSTEM = 3K9Ω MIN, 0.5W MIN OR 1KΩ MIN, 2.0W MIN
48V MAX SYSTEM = 15KΩ MIN, 0.5W MIN OR 3K9Ω MIN, 2.0W MIN

SWITCHES FOR STAGE OPERATION
CUSTOMER SUPPLIED

Two Stage Configuration	Config.: 4	Two/Three Stage Voltage Free Activation Configuration	Config.: 5	Three/Four Stage Configuration	Config.: 6
Line Stage Monitoring (Use suitable monitoring relays/modules) Not to be used for reverse polarity monitoring		Customer Set H1 & H2 to Negative Switching (See Below)		Independent Stage Input Line Stage Monitoring (use suitable monitoring relays/modules) Set to positive switching (default)	
Stage 1: Apply Power to Stage 1 +ve & Stage 1 -ve Stage 2: Apply Power to Stage 2 +ve & Stage 2 -ve		Power: +ve & -ve Stage 1: Connect Stage 1 -ve to Common -ve Stage 2: Cconnect Stage 2 -ve to Common -ve Stage 3: Connect both Stage 1 -ve & Stage 2 -ve to Common -ve		Stage 1: Apply Power to Stage 1 +ve & Stage 1 -ve Stage 2: Apply Power to Stage 2 +ve & Stage 2 -ve Stage 3: Apply Power to Stage 3 +ve & Stage 3 -ve Stage 4: Apply Power to Stage 2 +ve & Stage 2 -ve & Apply Power to Stage 3 +ve & Stage 3 -ve	

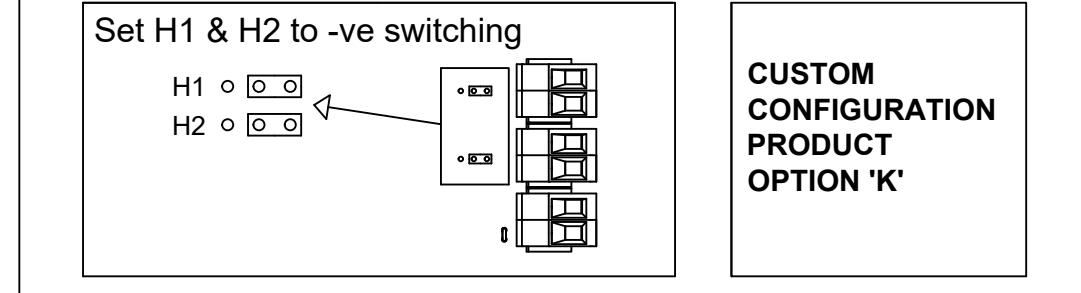
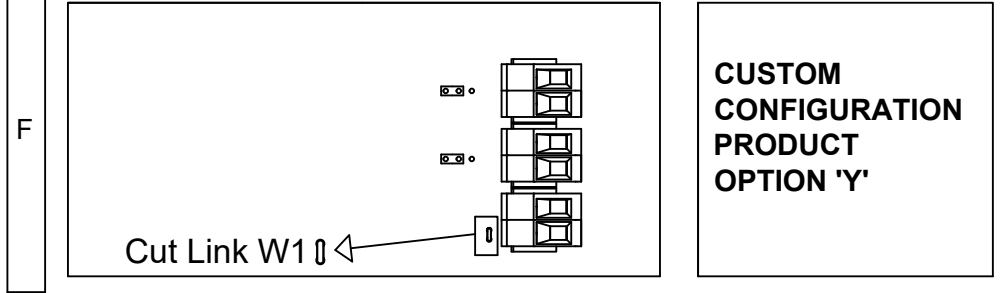
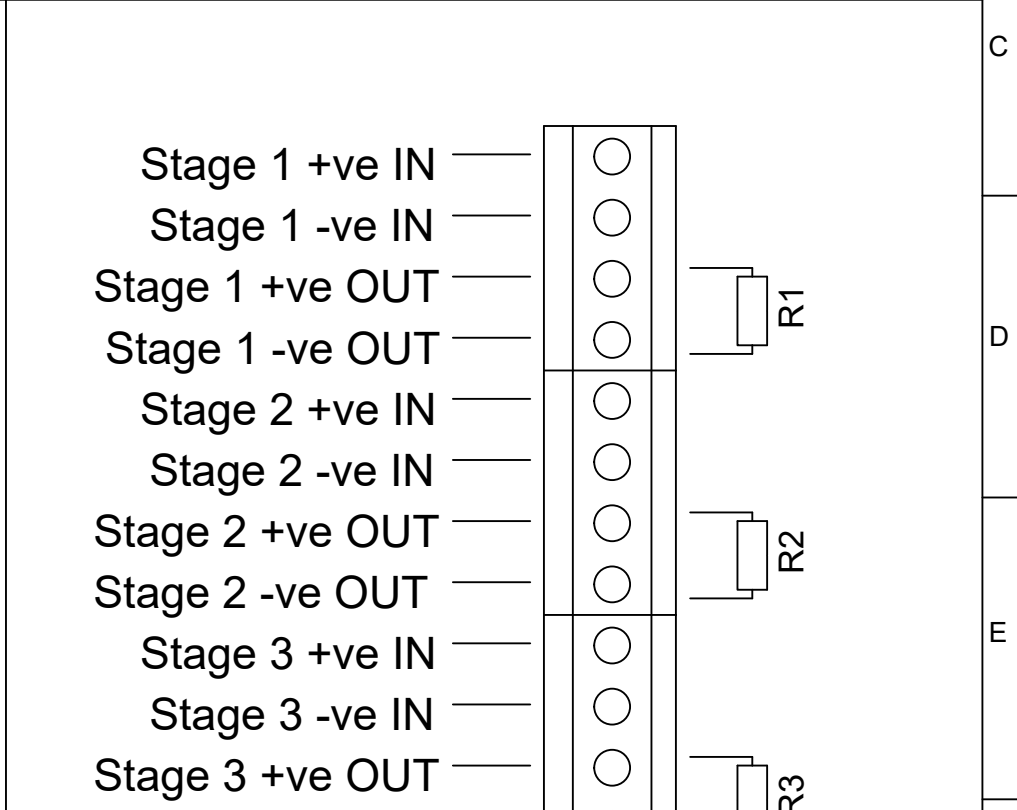
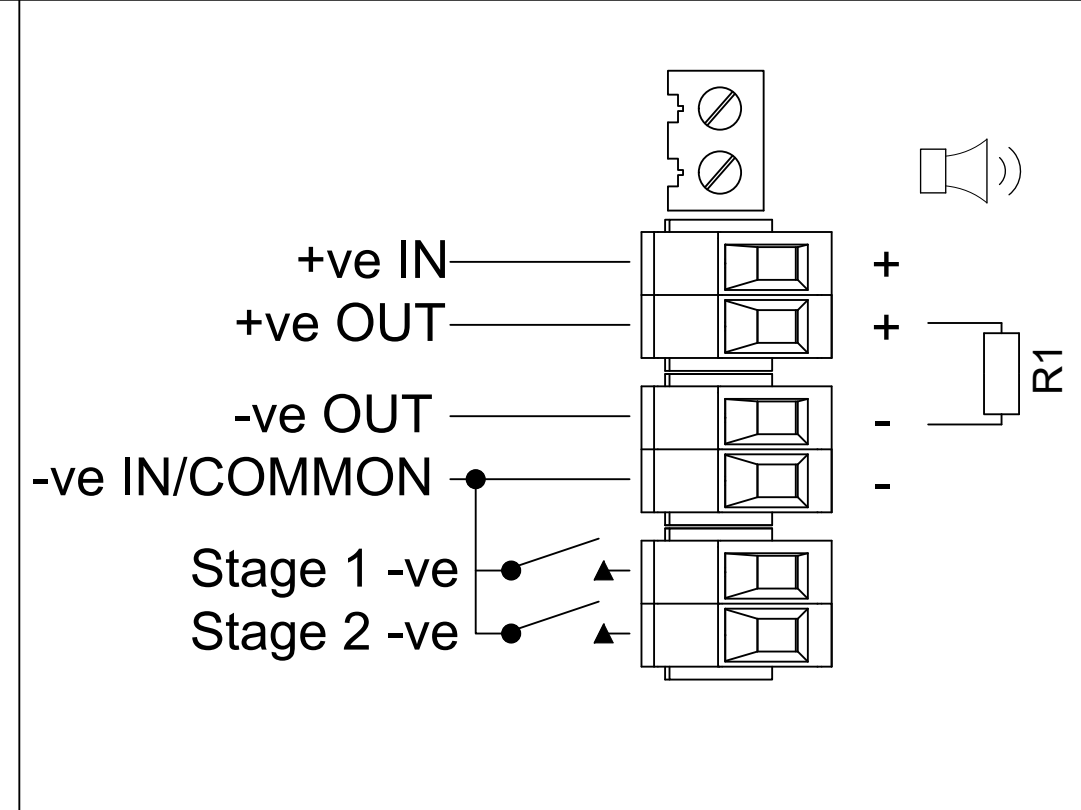
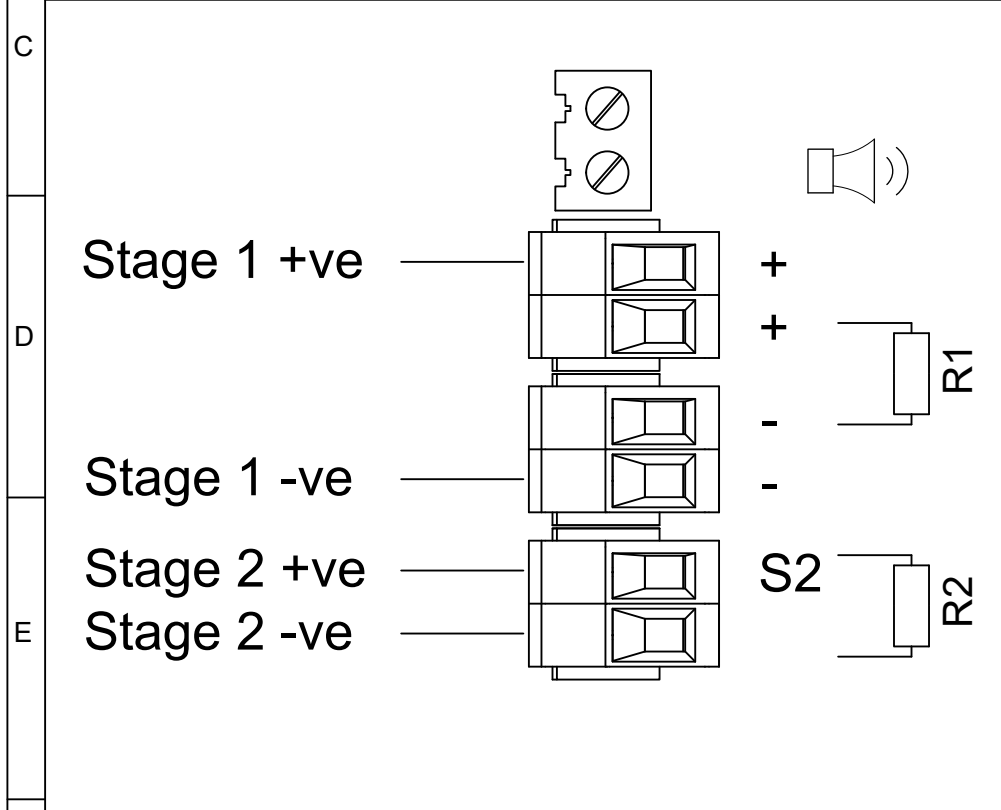

(CONFIGURATION SHOWS OPTIONAL
ADDITIONAL TERMINAL PCBA -
PRODUCT OPTION 'V')

DRAWING TO BS8888:2000 GEOMETRIC TOLERANCES TO ISO1101:1983 LINEAR DIMENSIONAL TOLS ANGULAR DIMENSIONAL TOLS	DRAWN R.S.RAIT	DATE 19/01/2022	SURFACE FINISH	WEIGHT (Kg)	THIS DRAWING AND ANY INFORMATION OR DESCRIPTIVE MATTER THEREIN IS COMMUNICATED IN CONFIDENCE AND IS THE COPYRIGHT PROPERTY OF EUROPEAN SAFETY SYSTEMS LTD. NEITHER THE WHOLE OR ANY EXTRACT MAY BE DISCLOSED, LOANED, COPIED OR USED FOR MANUFACTURING OR TENDERING PURPOSES WITHOUT THEIR WRITTEN CONSENT.	 EUROPEAN SAFETY SYSTEMS LTD IMPRESS HOUSE MANSELL ROAD ACTON LONDON W3 7QH WWW.E2S.COM	ALL DIMENSIONS IN MM IF IN DOUBT, ASK - DO NOT SCALE	 A3
	CHECKED B.ISARD	DATE 19/01/2022	MATERIAL	TITLE D2xS2 DC SOUNDER WIRING DIAGRAMS				
	STANDARDS D2x	APPROVED R.N.POTTS	DATE 19/01/2022	ALTERNATIVE MATERIAL			SCALE NTS	

ISSUE	MOD No.	REASON - INITIAL - DATE
1		INTRODUCTION RSR - 06/09/2023



Single Stage Configuration	Config.: 1a	Three/Four Stage Configuration	Config.: 1b	Two Stage Voltage Free Activation Configuration	Config.: 2
----------------------------	-------------	--------------------------------	-------------	---	------------

Stage 1: Apply Power to Stage 1 Live & Stage 1 Neutral	Stage 1: Apply Power to Live & Neutral Stage 2: Apply Power to Live & Neutral & connect Stage 2 to Common Stage 3: Apply Power to Live & Neutral & connect Stage 3 to Common Stage 4: Apply Power to Live & Neutral & connect both Stage 2 & Stage 3 to Common	Power: Live & Neutral Stage 1: Connect Stage 1 to Common Stage 2: Connect Stage 2 to Common Stage 3: Connect both Stage 1 & Stage 2 to Common
--	--	--

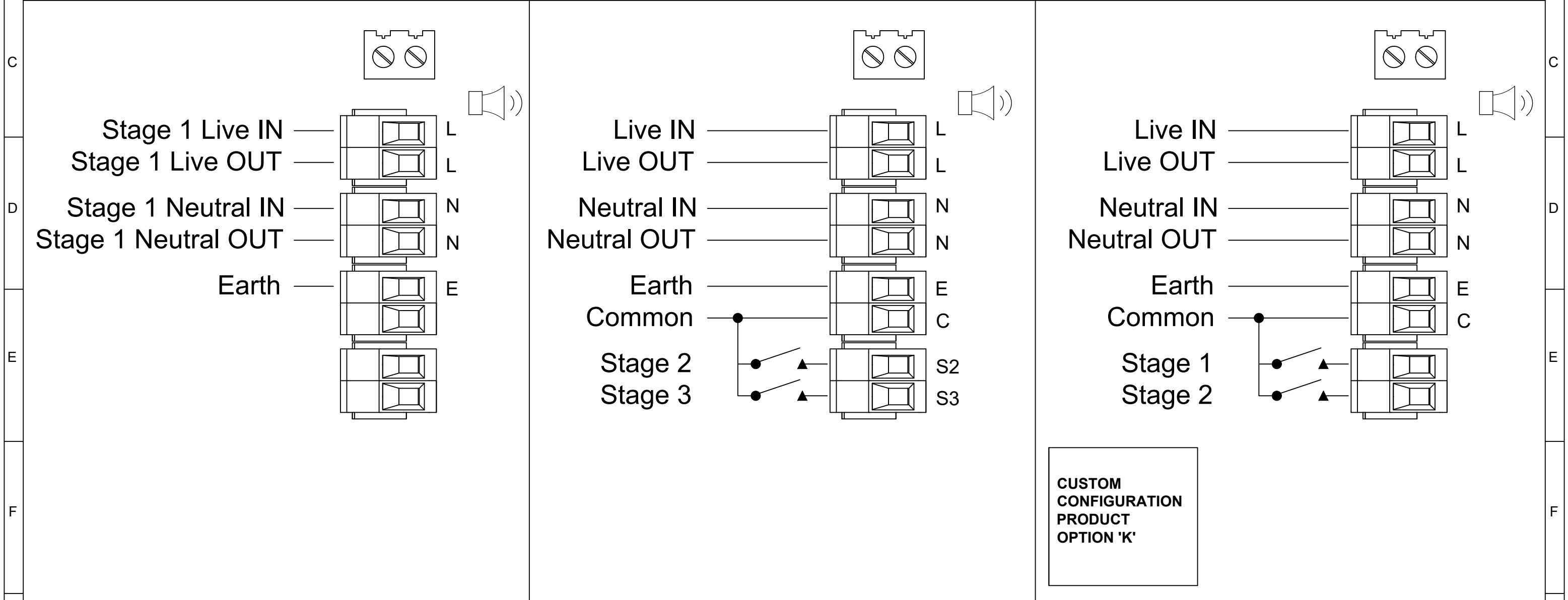

**CUSTOM
CONFIGURATION
PRODUCT
OPTION 'K'**

DRAWING TO BS8888:2000 GEOMETRIC TOLERANCES TO ISO1101:1983 LINEAR DIMENSIONAL TOLS ANGULAR DIMENSIONAL TOLS	DRAWN R.S.RAIT	DATE 19/01/2022	SURFACE FINISH	WEIGHT (Kg)	THIS DRAWING AND ANY INFORMATION OR DESCRIPTIVE MATTER THEREIN IS COMMUNICATED IN CONFIDENCE AND IS THE COPYRIGHT PROPERTY OF EUROPEAN SAFETY SYSTEMS LTD. NEITHER THE WHOLE OR ANY EXTRACT MAY BE DISCLOSED, LOANED, COPIED OR USED FOR MANUFACTURING OR TENDERING PURPOSES WITHOUT THEIR WRITTEN CONSENT. © EUROPEAN SAFETY SYSTEMS LTD. AS PER LATEST DATE OF ISSUE SHOWN ABOVE	warning signals EUROPEAN SAFETY SYSTEMS LTD IMPRESS HOUSE MANSELL ROAD ACTON LONDON W3 7QH WWW.E2S.COM	ALL DIMENSIONS IN MM IF IN DOUBT, ASK - DO NOT SCALE		A3		
	CHECKED B.ISARD	DATE 19/01/2022	MATERIAL				TITLE D2xS2 AC SOUNDER WIRING DIAGRAMS				
	STANDARDS D2x	APPROVED R.N.POTTS	DATE 19/01/2022	ALTERNATIVE MATERIAL			SCALE NTS	SHEET 1 OF 1	DRAWING NUMBER D252-06-005		

EU Declaration of Conformity



Manufacturer: European Safety Systems Ltd.
Impress House, Mansell Road, Acton
London, W3 7QH
United Kingdom

Authorised Representative: E2S Warnsignaltechnik UG
Charlottenstrasse 45-51
72764 Reutlingen
Germany

Equipment Type: D2xS1, D2xS2, D2xL1, D2xL2, D2xC1X05, D2xC1X10
D2xB1X05, D2xB1X10, D2xB1LD2, D2xB1XH1, D2xB1XH2, D2xB1LD3
D2xC2X05, D2xC2X10, D2xC2LD2, D2xC2XH1, D2xC2XH2, D2xC2LD3
D2xJ1

Directive 2014/34/EU: Equipment and Protective Systems for use in Potentially Explosive Atmospheres (ATEX)

Notified Body for EU type Examination (Module B):	UL International Demko A/S Notified Body No.: 0539 Borupvang 5A, 2750 Ballerup, Denmark
EU-type Examination Certificate (Module B):	DEMKO 14 ATEX 4786493904X
Notified Body for Quality Assurance Notification / Conformity to EU-type based on quality assurance of the production process (Module D):	Sira Certification Service Notified Body No.: 2813 CSA Group Netherlands B.V, Utrechtseweg 310, 6812 AR, Arnhem, Netherlands
Quality Assurance Notification (Module D):	SIRA 05 ATEX M342
Provisions fulfilled by the equipment:	II 3G Ex ec IIC T6/T5/T4A/T4/T3C/T3/T2/T1 Gc II 3D Ex tc IIIC T55/75/80/85/90/93/95/105/109/110/119°C Dc Ingress / Dust Protection to EN60079-0 / EN60079-31: IP66
Standards applied:	EN IEC 60079-0:2018 EN IEC 60079-7:2015 +A1:2018 EN 60079-31:2014

Directive 2014/30/EU: Electromagnetic Compatibility Directive (EMC)

Standards applied:	EN 61000-6-1:2007 EN 61000-6-2:2005 EN 61000-6-3:2007 / A1:2011 / AC: 2012 EN 61000-6-4:2007 / A1: 2011
--------------------	--

Directive 2011/65/EU: Restriction of the use of certain hazardous substances in electrical and electronic equipment (RoHS)

The product and all the components contained within it are in accordance with the restriction of the use of hazardous substances in electrical and electronic equipment, including amendment by Directive 2015/863/EU.

EU Declaration of Conformity



Regulation (EC) 1907/2006: Registration, Evaluation, Authorisation and Restriction of Chemicals (REACH)

The product and all the components contained within it are free from substances of very high concern.

Other Standards and Regulations

EN 60529:1992+A2:2013 - Degrees of protection provided by enclosures (IP code) – enclosure rated:

IP66 All units

IP66/67 D2xL1, D2xL2, D2xS2 only

On behalf of European Safety Systems Ltd., I declare that, on the date the equipment accompanied by this declaration is placed on the market, the equipment conforms with all technical and regulatory requirements of the above listed directives, regulations and standards.

This Declaration is issued under the sole responsibility of the manufacturer.

A handwritten signature in black ink, appearing to read 'Martin Streetz'.

Martin Streetz
Quality Assurance Manager

Document No.: DC-061_Issue_K
Date and Place of Issue: London, 04/12/2023



UKCA Declaration of Conformity



Manufacturer: European Safety Systems Ltd.
Impress House, Mansell Road, Acton
London, W3 7QH
United Kingdom

Equipment Type: D2xS1, D2xS2, D2xL1, D2xL2, D2xC1X05, D2xC1X10
D2xB1X05, D2xB1X10, D2xB1LD2, D2xB1XH1, D2xB1XH2, D2xB1LD3
D2xC2X05, D2xC2X10, D2xC2LD2, D2xC2XH1, D2xC2XH2, D2xC2LD3
D2xJ1

Directive UKSI 2016:1107 (as amended by UKSI 2019:696) – Schedule 3A, Part 1 : Product or Protective System Intended for use in Potentially Explosive Atmospheres (UKCA)

Notified Body for UK type Examination (Module B):	UL International (UK) Ltd Notified Body No.: 0843 Unit 1-3 Horizon Kingsland Business Park, Wade Road, Basingstoke, Hampshire RG24 8AH UK
UK-type Examination Certificate (Module B):	UL21UKEX2131X
Notified Body for Quality Assurance Notification / Conformity to EU-type based on quality assurance of the production process (Module D):	Sira Certification Service Notified Body No.: 0518 Rake Lane, Eccleston, Chester CH4 9JN, UK
Quality Assurance Notification (Module D):	CSAE 22UKQAN0046
Provisions fulfilled by the equipment:	II 3G Ex ec IIC T6/T5/T4A/T4/T3C/T3/T2/T1 Gc II 3D Ex tc IIIC T55/75/80/85/90/93/95/105/109/110/119°C Dc Ingress / Dust Protection to EN60079-0 / EN60079-31: IP66 All units
Standards applied:	EN IEC 60079-0:2018 EN IEC 60079-7:2015 +A1:2018 EN 60079-31:2014

Directive 2014/30/EU: Electromagnetic Compatibility Directive (EMC)

Standards applied:	EN 61000-6-1:2007 EN 61000-6-2:2005 EN 61000-6-3:2007 / A1:2011 / AC: 2012 EN 61000-6-4:2007 / A1: 2011
--------------------	--

Directive 2011/65/EU: Restriction of the use of certain hazardous substances in electrical and electronic equipment (RoHS)

The product and all the components contained within it are in accordance with the restriction of the use of hazardous substances in electrical and electronic equipment, including amendment by Directive 2015/863/EU.



UKCA Declaration of Conformity



Regulation (EC) 1907/2006: Registration, Evaluation, Authorisation and Restriction of Chemicals (REACH)

The product and all the components contained within it are free from substances of very high concern.

Other Standards and Regulations

EN 60529:1992+A2:2013 - Degrees of protection provided by enclosures (IP code) – enclosure rated:

IP66 All units

IP66/67 D2xL1, D2xL2, D2xS2 only

On behalf of European Safety Systems Ltd., I declare that, on the date the equipment accompanied by this declaration is placed on the market, the equipment conforms with all technical and regulatory requirements of the above listed directives, regulations and standards.

This Declaration is issued under the sole responsibility of the manufacturer.

Martin Streetz
Quality Assurance Manager

Document No.:
Date and Place of Issue:

DC-102_Issue_B
London, 04/12/2023

Page left Intentionally blank

Page left Intentionally blank

Page left Intentionally blank