

**INSTRUCTION MANUAL**  
**D1xL1 & D1xL2**  
**Loudspeaker**  
**Class I, Zone 1, 2, 21 & 22**

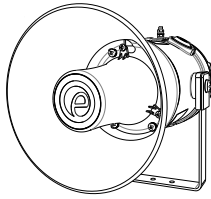

D1xL1F

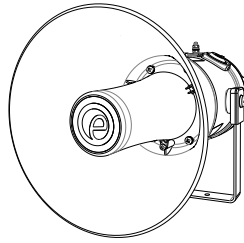

D1xL2F

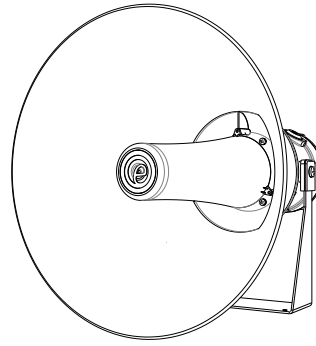

D1xL2H

**1) Product Table**

Unit Type Code	Input	Power (Watts)	Max I/P Volts	Sound Pressure Level dB(A)	
				Max Rated	Pink Noise @ 1W
D1xL1FV100-A	100V Line	15	100	117	101
D1xL1FV070-A	70V Line	15	70		
D1xL1FR008-A	8 Ohm	15	10.95		
D1xL1FR016-A	16 Ohm	15	15.49		
D1xL1FV725-A	25V	15	25V		
	70V	15	70.7V		
D1xL2FV100-A	100V Line	25	100	123	104
D1xL2FV070-A	70V Line	25	70		
D1xL2FR008-A	8 Ohm	25	14.14		
D1xL2FR016-A	16 Ohm	25	20		
D1xL2FV725-A	25V	25	25V		
	70V	25	70.7V		
D1xL2HV100-A	100V Line	25	100	126	106
D1xL2HV070-A	70V Line	25	70		
D1xL2HR008-A	8 Ohm	25	14.14		
D1xL2HR016-A	16 Ohm	25	20		
D1xL2HV725-A	25V	25	25V		
	70V	25	70.7V		
Frequency Range: 400Hz to 8000Hz					
The table shows the input current taken by the various Loudspeakers. Nominal current at nominal voltage.					
Table 1: Electrical Ratings.					

**2) Warnings**



**CAUTION**  
 TO REDUCE THE RISK OF IGNITION OF HAZARDOUS ATMOSPHERES:

DISCONNECT FROM SUPPLY BEFORE OPENING.  
 KEEP TIGHTLY CLOSED WHEN IN OPERATION.

**WARNING**  
 FIT SEALING FITTING IN CONDUIT RUNS WITHIN 18 INCHES FROM ENCLOSURE.

EQUIPMENT MUST NOT BE INSTALLED WITH THE HORN FACING UPWARDS OF HORIZONTAL

DO NOT OPEN WHEN AN EXPLOSIVE ATMOSPHERE IS PRESENT  
 DO NOT OPEN WHEN ENERGISED

POTENTIAL ELECTROSTATIC CHARGING HAZARD - CLEAN ONLY WITH A DAMP CLOTH

ENCLOSURE ENTRIES: TWIN M20 X 1.5 / SINGLE 1/2" NPT  
 ATEX/IECEx & UKEx INSTALLATIONS: IF TEMPERATURE EXCEEDS 70°C AT ENTRY OR 80°C AT BRANCHING POINT USE SUITABLE RATED CABLE AND GLANDS

**ATTENTION**

POUR REDUIRE LE RISQUE D'INFLAMMATION DES ATMOSPHERES DANGEREUSES :

COUPER L'ALIMENTATION AVANT OUVERTURE.  
 CONSERVER FERMÉ PENDANT LE FONCTIONNEMENT.

**AVERTISSEMENT**

CONDUITS DOIVENT ETRE SCELLES EN MOINS DE 18 POUCHES.  
 ÉQUIPEMENT NE DOIT PAS ETRE INSTALLE AVEC LE KLAXON TOURNEE VERS LE HAUT DE HORIZONTAL.

NE PAS OUVRIR UN PRESENCE D'ATMOSPHERE EXPLOSIVE  
 NE PAS OUVRIR ENERGIE

DANGER POTENTIEL CHARGE ÉLECTROSTATIQUE - NETTOYER UNIQUEMENT AVEC UN CHIFFON HUMIDE

ENTRÉES DE BOÎTIER: 2 x M20 X 1.5 / 1 x 1/2" NPT

ATEX/IECEx & UKEx INSTALLATIONS: SI LA TEMPÉRATURE DÉPASSE 70 °C À L'ENTRÉE OU 80 °C AU POINT DE BRANCHEMENT, UTILISER UN CÂBLE ET DES JOINTS D'ÉTANCHÉITÉ APPROPRIÉS

### 3) Marking \* Rating Information

#### 3.1 Class/Division Ratings for US & Canada

Standards	
UL1203 & CSA C22.2 No 30 Ed. 4	
Class Division Ratings for US (NEC)	
Model No:	Rating
D1xL1-V100-A/ D1xL1-V070-A/ D1xL1-R008-A/ D1xL1-R016-A	Class I Div 1 ABCD T5 Ta -55°C to +85°C Class I Div 1 ABCD T6 Ta -55°C to +65°C
D1xL1-V725-A	Class I Div 1 ABCD T4 Ta -55°C to +85°C Class I Div 1 ABCD T5 Ta -55°C to +80°C Class I Div 1 ABCD T6 Ta -55°C to +65°C
D1xL2-V100-A/ D1xL2-V070-A/ D1xL2-R008-A/ D1xL2-R016-A	Class I Div 1 ABCD T5 Ta -55°C to +85°C Class I Div 1 ABCD T6 Ta -55°C to +60°C
D1xL2-V725-A	Class I Div 1 ABCD T4 Ta -55°C to +85°C Class I Div 1 ABCD T5 Ta -55°C to +75°C Class I Div 1 ABCD T6 Ta -55°C to +60°C
Class Division Ratings for Canada (CEC)	
Model No:	Rating
D1xL1-V100-A/ D1xL1-V070-A/ D1xL1-R008-A/ D1xL1-R016-A/ D1xL1-V725-A	Class I Div 1 ABCD T5 Ta -55°C to +75°C Class I Div 1 ABCD T6 Ta -55°C to +65°C
D1xL2-V100-A/ D1xL2-V070-A/ D1xL2-R008-A/ D1xL2-R016-A/ D1xL2-V725-A	Class I Div 1 ABCD T5 Ta -55°C to +75°C Class I Div 1 ABCD T6 Ta -55°C to +60°C
Class Zone Ratings for US (NEC)	
Standards	
UL60079-0 Ed 7 CSA C22.2 No. 60079-0 Ed 4 UL60079-1 Ed 7 CSA C22.2 No. 60079-1 Ed 3 UL60079-31 Ed 2 CSA C22.2 No. 60079-31 Ed 2 Installation must be carried out in compliance with the National Electric Code / Canadian Electric Code	
Model No:	Rating
D1xL1-V100-A/ D1xL1-V070-A/ D1xL1-R008-A/ D1xL1-R016-A	Class I Zone 1 AEx db IIC T5 Gb Ta -55°C to +75°C Class I Zone 1 AEx db IIC T5 Gb Ta -55°C to +60°C Zone 21 AEx tb IIIC 90°C Db Ta -55°C to +75°
D1xL1-V725-A	Class I Zone 1 AEx db IIC T5 Gb Ta -55°C to +75°C Class I Zone 1 AEx db IIC T6 Gb Ta -55°C to +60°C Zone 21 AEx tb IIIC 91°C Db Ta -55°C to +75°
D1xL2-V070-A/ D1xL2-R008-A/ D1xL2-R016-A	Class I Zone 1 AEx db IIC T5 Gb Ta -55°C to +75°C Class I Zone 1 AEx db IIC T6 Gb Ta -55°C to +55°C Zone 21 AEx tb IIIC 95°C Db Ta -55°C to +75°
D1xL2-V725-A	Class I Zone 1 AEx db IIC T4 Gb Ta -55°C to +75°C Class I Zone 1 AEx db IIC T5 Gb Ta -55°C to +70°C Class I Zone 1 AEx db IIC T6 Gb Ta -55°C to +55°C Zone 21 AEx tb IIIC 97°C Db Ta -55°C to +75°
D1xL2-V100-A	Class I Zone 1 AEx db IIC T4 Gb Ta -55°C to +75°C Class I Zone 1 AEx db IIC T5 Gb Ta -55°C to +70°C Class I Zone 1 AEx db IIC T6 Gb Ta -55°C to +55°C Zone 21 AEx tb IIIC 91°C Db Ta -55°C to +75°
Class Zone Ratings for Canada (CEC)	
Model No:	Rating
D1xL1-V100-A/ D1xL1-V070-A/ D1xL1-R008-A/ D1xL1-R016-A	Ex db IIC T5 Gb -55°C to +75°C Ex db IIC T6 Gb -55°C to +60°C Ex tb IIIC T90°C Db -55°C to +75°C
D1xL1-V725-A	Ex db IIC T5 Gb -55°C to +75°C Ex db IIC T6 Gb -55°C to +60°C Ex tb IIIC T91°C Db -55°C to +75°C

D1xL2-V070-A / D1xL2-R008-A / D1xL2-R016-A/	Ex db IIC T5 Gb -55°C to +75°C Ex db IIC T6 Gb -55°C to +55°C Ex tb IIIC T95°C Db -55°C to +75°C
D1xL2-V725-A	Ex db IIC T4 Gb -55°C to +75°C Ex db IIC T5 Gb -55°C to +70°C Ex db IIC T6 Gb -55°C to +55°C Ex tb IIIC T97°C Db -55°C to +75°C
D1xL2-V100-A	Ex db IIC T4 Gb -55°C to +75°C Ex db IIC T5 Gb -55°C to +70°C Ex db IIC T6 Gb -55°C to +55°C Ex tb IIIC T91°C Db -55°C to +75°C
Installation must be carried out in compliance with the National Electric Code / Canadian Electric Code	

#### 3.2 ATEX / IECEx & UKEx Ratings

Standards	
EN60079-0:2018/IEC60079-0:2017 (ed.7): Explosive Atmospheres - Equipment General Requirements. EN60079-1:2014/IEC60079-1:2014 (ed.7): Explosive Atmospheres - Equipment Protection by Flameproof Enclosures "d". EN60079-31:2014/IEC60079-31:2022 (ed.3): Explosive Atmospheres - Equipment Dust Ignition Protection by enclosure "t".	
Model No:	Rating
D1xL1-V070-A/ D1xL1-R008-A/ D1xL1-R016-A/	Ex db IIC T5 Gb Ta -55°C to +75°C Ex db IIC T6 Gb Ta -55°C to +60°C Ex tb IIIC T86°C Db Ta -55°C to +75°C
D1xL1-V725-A	Ex db IIC T5 Gb Ta -55°C to +75°C Ex db IIC T6 Gb Ta -55°C to +60°C Ex tb IIIC T91°C Db Ta -55°C to +75°C
D1xL1-V100-A	Ex db IIC T5 Gb Ta -55°C to +75°C Ex db IIC T6 Gb Ta -55°C to +60°C Ex tb IIIC T92°C Db Ta -55°C to +75°C
D1xL2-V070-A/ D1xL2-R008-A/ D1xL2-R016-A/	Ex db IIC T5 Gb Ta -55°C to +75°C Ex db IIC T6 Gb Ta -55°C to +55°C Ex tb IIIC T91°C Db Ta -55°C to +75°C
D1xL2-V725-A	Ex db IIC T4 Gb Ta -55°C to +75°C Ex db IIC T5 Gb Ta -55°C to +70°C Ex db IIC T6 Gb Ta -55°C to +55°C Ex tb IIIC T97°C Db Ta -55°C to +75°C
D1xL2-V100-A	Ex db IIC T4 Gb Ta -55°C to +75°C Ex db IIC T5 Gb Ta -55°C to +70°C Ex db IIC T6 Gb Ta -55°C to +50°C Ex tb IIIC T98°C Db Ta -55°C to +75°C
See Product table for electrical ratings of each unit model	

Certificate No. DEMKO 19ATEX2141X  
IECEx ULD 19.0008X  
UKEx UL21UKEX2132X

Epsilon x  
Equipment Group  
and Category:



II 2G  
II 2D

CE Marking and  
Notified Body No.



2813

UKCA Marking and  
Notified Body No.



0518

#### 3.3 UL Certification

All Loudspeakers comply with the following standards:  
 UL 1480A (Ed 1) – Speakers for Commercial and Professional Use  
 CSA C22.2 No. 205 (Ed 3) – Signal Equipment  
 CE, UKCA, CSFM

D1xL1FV100, D1xL2FV100, D1xL2HV100, D1xL1FV725, D1xL2FV725, D1xL2HV725, D1xL1FR008, D1xL2FR008, D1xL2HR008, D1xL1FR016, D1xL2FR016, D1xL2HR016 Loudspeakers also comply with the following standards:  
 UL 1480 (Ed 6) – Speakers for Fire Alarm and Signaling Systems, Including Accessories  
 CAN/ULC-541 (Ed 4) – Speakers for Fire Alarm and Signaling Systems, Including Accessories

#### 4) Zones, Gas Group, Category and Temperature Classification

The units can be installed in locations with the following conditions:

Area Classification Gas	
Zone 1	Explosive gas air mixture likely to occur in normal operation.
Zone 2	Explosive gas air mixture not likely to occur in normal operation, and if it does, it will only exist for a short time.
Gas Groupings	
Group IIA	Propane
Group IIB	Ethylene
Group IIC	Hydrogen and Acetylene
Temperature Classification for Gas Applications	
T1	450° C
T2	300° C
T3	200° C
T4	135° C
T5	100°C (D1xL2-V100-A & D1xL2-V725 up to 70°C ambient)
T6	85°C (D1xL1 up to 60°C ambient, D1xL2 up to 55°C ambient)
Area Classification Dust	
Zone 21	Explosive dust air mixture likely to occur in normal operation.
Zone 22	Explosive dust air mixture not likely to occur in normal operation, and if it does, it will only exist for a short time.
Dust Groupings	
Group IIIA	Combustible Dusts
Group IIIB	Non-Conductive Dusts
Group IIIC	Conductive Dusts
Equipment Category	
2G, 2D	
Equipment Protection Level	
Gb, Gc, Db, Dc	
Maximum Surface Temperature for Dust Applications	
86°C (D1xL1-V070-A, D1xL1-R008-A, D1xL1-R016-A) 92°C (D1xL1-V100-A) 91°C (D1xL2-V070-A, D1xL2-R008-A, D1xL2-R016-A, D1xL1-V725-A) 97°C (D1xL2-V725-A) 98°C (D1xL2-V100-A)	
Ambient Temperature Range	
-55°C to +75°C (-67°F to +167°F)	

IP Rating
IP66 to EN60529 4 / 4X / 3R / 13 to UL50E / NEMA250
Installation must be carried out in compliance with the latest issue of the following standards:  EN60079-14 / IEC60079-14: Explosive atmospheres - Electrical installations design, selection and erection EN60079-10-1 / IEC60079-10-1: Explosive atmospheres - Classification of areas. Explosive gas atmospheres EN60079-10-2 / IEC60079-10-2: Explosive atmospheres - Classification of areas. Explosive dust atmospheres

#### 5) Specific Conditions of Installation

ATEX/IECEX & UKEx Installations:

The cable entries have two M20 x 1.5 – 6H entry thread and a single ½" NPT thread. If the installation is made using cable glands, only suitably rated ATEX/IECEX or UKEx certified cable glands must be used. They must be suitable for the type of cable being used and also meet the requirements of the current installation standards EN 60079-14 / IEC60079-14.

If the installation is made using conduit, openings must have a sealing fitting connected as close as practical to the wall of the enclosure, but in no case more than the size of the conduit or 50mm, whichever is the lesser.

Any unused cable entries must be closed with suitably rated ATEX/IECEX or UKEx certified blanking plugs.

For high ambient temperatures the cable entry temperature may exceed 70°C or the cable branching point temperature may exceed 80°C and therefore suitable heat resisting cables and cable glands must be used, with a rated service temperature at least as stated below:

Max Ambient Temp (°C)	40	45	50	55	60	65	70	75
D1xL1-V070-A, D1xL1-V100-A, D1xL1-R008-A, D1xL1-R016-A, Min. Rating (°C)			70	75	80	85	90	95
D1xL2-V070-A, D1xL2-V100-A, D1xL2-R008-A, D1xL2-R016-A, D1xL1-V725-A Min. Rating (°C)		70	75	80	85	90	95	100
D1xL2-V725-A Min. Rating (°C)	70	75	80	85	90	95	100	105

Table 2a: ATEX / IECEX & UKEx Min. Ratings of Cables & Cable Glands.

NEC / CEC Installations:

The cable entries have two M20 x 1.5 – 6H entry thread and a single ½" NPT thread. If the installation is made using cable glands, only suitably rated and certified cable glands must be used. They must be suitable for the type of cable being used and also meet the requirements of the current installation standards for NEC and CEC.

If the installation is made using conduit, openings must have a sealing fitting connected within 18" of enclosure.

Any unused cable entries must be closed with suitably rated and certified blanking plugs.

Class Zone Installation only:

For high ambient temperatures the cable entry temperature may exceed 60°C or the cable branching point temperature may exceed 60°C and therefore suitable heat resisting cables and cable glands must be used, with a rated service temperature at least as stated below:

**All Installations:**

The plastic horn is not anti-static and the metallic enclosure has a non-conductive coating. These may generate an ignition-capable level of electrostatic charges under certain extreme conditions. The user should ensure that the equipment is not installed in a location where it may be subjected to external conditions that might cause a build-up of electrostatic charges on non-conducting surfaces.

Only the explosionproof cover is to be used for access to the enclosure for installation, service and maintenance.

**6) Specific Conditions for Safe Use**

Flameproof threaded joints and cemented joints are not permitted to be repaired.

**7) Product Mounting and Access**

**7.1 Mounting**

The D1x Loudspeaker is available as a variant with no horn fitted in the factory. The Horn threaded nose portion has a fitment thread of 1-3/8" – 18 UNF (to BS1580 or ANSI B1.1). The customer is responsible for sourcing and correctly fitting a suitable horn that meets all of the relevant safety requirements.

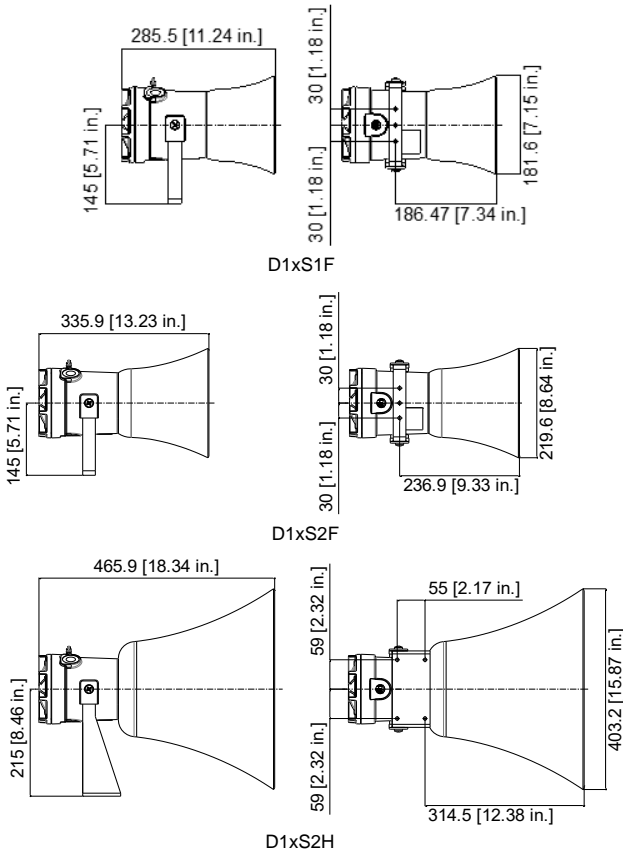
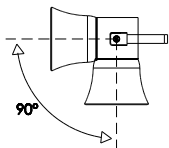

Fig 1: Mounting Locations

The Equipment must not be installed with the horn facing upwards of horizontal.



**7.2 Installation procedure**

- a. Secure the D1x unit to a flat surface via the three 7mm fixing holes in the mounting bracket.
- b. Remove the explosionproof cover of the alarm horn by unscrewing it, taking care not to damage the explosionproof threads in the process (Refer to section 7.4).

Max Ambient Temp (°C)	30	35	40	45	50	55	60	65	70	75
D1xL1-V070-A, D1xL1-V100-A, D1xL1-R008-A, D1xL1-R016-A, Min. Rating (°C)			60	65	70	75	80	85	90	95
D1xL2-V070-A, D1xL2-V100-A, D1xL2-R008-A, D1xL2-R016-A, D1xL1-V725-A, Min. Rating (°C)		60	65	70	75	80	85	90	95	100
D1xL2-V725-A Min. Rating (°C)	60	65	70	75	80	85	90	95	100	105

Table 2b: Class Zone Min. Ratings of Cables & Cable Glands.

- c. Fit an M20/NPT suitably rated cable gland or conduit entry into the hole in the enclosure and connect the field wiring to the appropriate terminals as shown in D190-06-201. The power supply terminals are duplicated so that units may be connected in parallel. An end of line monitoring resistor may be fitted to units (see section 10). If the second and third M20/NPT entries are not used, suitably rated stopping plugs must always be fitted.
- d. Replace the explosionproof cover of the loudspeaker, taking care not to damage the explosionproof threads. Tighten fully.

**7.3 Hornless Variants**

The D1x Loudspeaker is also available as a variant with no horn fitted in the factory. The Horn threaded nose portion has a fitment thread of 1-3/8" – 18 UNF (to BS1580 or ANSI B1.1). The customer is responsible for sourcing and correctly fitting a suitable horn that meets all of the relevant safety requirements.

**7.4 Access to the Explosionproof Enclosure**

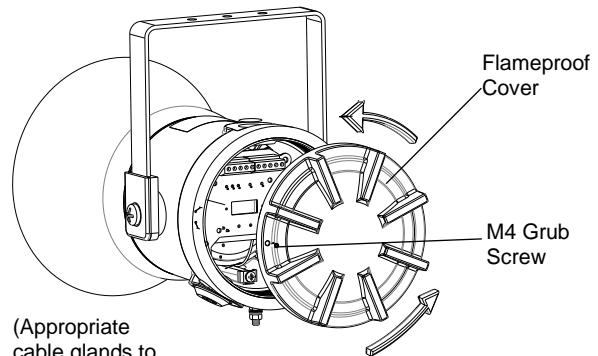

(Appropriate cable glands to be customer supplied)

Fig 2: Accessing the enclosure

To access the Ex d chamber, loosen the M4 grub screw on the cover. Open the enclosure by turning the cover counter-clockwise and remove the cover. Take extreme care not to damage the explosionproof threads in the process.

On completion of the installation the flameproof threaded joint should be inspected to ensure that they are clean and that they have not been damaged during installation.

Ensure the O-ring seal is in place and undamaged.

When fitting the flameproof cover ensure the thread is engaged correctly. Fully tighten the cover all the way, ensure no gap is visible between the cover and base of the sounder enclosure.

## 8) Installation Requirements

### 8.1 Safe Installation Requirements



Warning – High voltage may be present, risk of electric shock.  
DO NOT open when energised, disconnect power before opening.

The sounder must only be installed by suitably qualified personnel in accordance with the latest issues of the relevant standards.

The product must only be installed by suitably qualified personnel in accordance with the latest issues of the relevant standards.

The installation of the units must also be in accordance with the NEC / CEC and any local regulations and should only be carried out by a competent electrical engineer who has the necessary training.

### 8.2 Cable Selection and Connections

When selecting the cable size, consideration must be given to the input current that each unit draws (see table 1), the number of sounders on the line and the length of the cable runs. The cable size selected must have the necessary capacity to provide the input current to all the sounders connected to the line.

A single wire with a cross sectional area of up to 2.5mm<sup>2</sup> / AWG14 can be connected to each terminal way or if an input and output wire is required two wires can be connected to each terminal way when crimped with a ferrule. If more than one wire is fitted into a terminal a ferrule should be used to secure the wires. When connecting wires to the terminals great care should be taken to dress the wire so that when the cover is inserted into the chamber the wires do not exert excess pressure on the terminal blocks.

D1xL2 and D1xL1 8 ohm and 16 ohm low impedance loudspeakers have dual input terminals on the PCB assembly for input and output wiring. A cable of up to 4.0mm<sup>2</sup> can be connected to each terminal.

Wire insulation needs to be stripped 8mm. Wires may be fitted securely with crimped ferrules. Terminal screws need to be tightened down with a tightening torque of 0.45 Nm / 3.5 Lb-in.

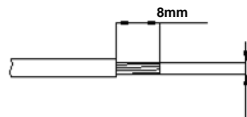

Line In: 0.2 - 2.5mm<sup>2</sup> / AWG24 - AWG14  
Low Impedance: 0.2 - 4mm<sup>2</sup> / AWG24 - AWG12

Figure 3: Wire Preparation.

When connecting wires to the terminals great care should be taken to dress the wires so that when the cover is inserted into the chamber the wires do not exert excess pressure on the terminal blocks. This is particularly important when using cables with large cross-sectional areas such as 2.5mm<sup>2</sup>.

### 8.3 Earthing

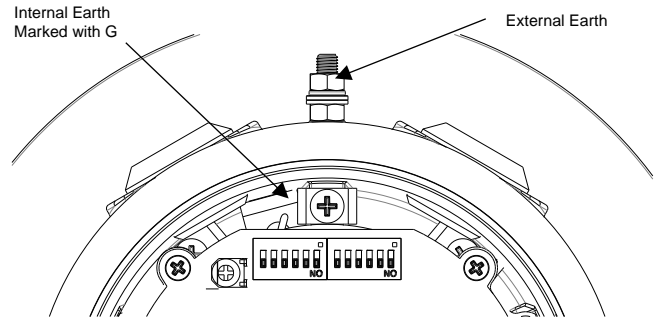

Figure 4: Earth Locations.

The unit has both a primary internal and secondary external earth fixing point.

Internal earth connections should be made to the internal Earth terminal in the base of the housing using a ring crimp terminal to secure the earth conductor under the earth clamp.

External earth connections can be made to the M5 earth stud (see Fig. 4), using a ring crimp terminal to secure the earth conductor to the earth stud. The external earth conductor should be at least 4mm<sup>2</sup> in size.

The external earth crimp ring should be located between the two M5 plain washers provided and securely locked down with the M5 spring washer and M5 nut.

The earth conductor should be at least equal in size and rating to the incoming power conductors but at least a minimum of 0.82mm<sup>2</sup> / 18AWG in size.

### 8.4 Cable Glands, Blanking Elements & Adapters

#### Ingress Protection

If a high IP (Ingress Protection) rating is required then a suitable sealing washer must be fitted under the cable glands or blanking plugs. A minimum ingress protection rating of IP6X must be maintained for installations in explosive dust atmospheres.

To maintain the ingress protection rating and mode of protection, the cable entries must be fitted with suitably rated cable entry and/or blanking devices during installation.

If entries are fitted with adaptors they must be suitably rated for the application. Fitting of blanking elements into adaptors is not permitted.

#### Adapters

The D1x Loudspeaker range can be supplied with the following types of adapters:

M20 to 1/2" NPT  
M20 to 3/4" NPT  
M20 to M25

It is important to note that stopping plugs cannot be fitted onto adapters, only directly onto the M20 entries.

Any other adapters used must be suitably rated and certified.

## 9) Wiring

D1xL2 and D1xL1 8 ohm and 16 ohm low impedance loudspeakers have dual input terminals on the PCB assembly for input and output wiring. A cable of up to 4.0mm<sup>2</sup> can be connected to each terminal.

D1xL2 and D1xL1 70V and 100V Line cable connections are made into the terminal blocks on the PCB assembly located in the explosionproof enclosure. See section 5 of this manual for access to the explosionproof enclosure. The 70V and 100V Line loudspeakers are fitted with a ten way terminal block. Terminal A is common and one of the other terminals B, C, D or E should be selected depending on what output level is required (see table below).

Terminals	D1xL2 (25W)	D1xL1 (15W)
A - B	25W	15W
A - C	12.5W	7.5W
A - D	6W	3W
A - E	2W	1W

D1xL2 and D1xL1 70V / 25V Line cable connections are made into the terminal blocks on the PCB assembly located in the explosionproof enclosure. See section 5 of this manual for access to the explosionproof enclosure. The 70V and 25V Line loudspeakers are fitted with a sixteen way terminal block. Terminal is common and one of the other terminals A, B, C, D, E, F, G or H should be selected depending on what output level is required (see table below).

Terminals	D1xL2-V725-A		D1xL2-V725-A	
	Voltage		Voltage	
	70V	25V	70V	25V
COM - A		15W		25W
COM - B		7.5W		12.5W
COM - C	15W	5W	25W	6W
COM - D	7.5W	4W	12.5W	4W
COM - E	5W	2W	6W	2W
COM - F	4W		4W	1W
COM - G	2W		2W	
COM - H			1W	

Refer to Wiring Schematic D190-06-201 Configs. 1a -2d for 70V & 100V Line in Loudspeakers, Config. 3 for Low impedance & Configs. 4a – 5f for 70V/25V Line in Loudspeakers.

## 10) End of Line Monitoring (DC Units)

On D1xL2 and D1xL1 Loudspeakers, DC line monitoring can be used if required. Both the Line In units and the Low Impedance units have blocking capacitors fitted. It should be noted that each loudspeaker has a 1M ohm bleed resistor connected across the blocking capacitor and this should be taken into account when selecting the value of the end of line monitoring resistance.

The end of line monitoring resistor can be connected across the terminals on the end of line unit.

For Line in units, the end of line resistor used must have a minimum resistance value of:

Minimum resistance 4k7 ohms                      Minimum Power 2.5W

For low impedance units the end of line resistor used must have a minimum resistance value of:

Minimum resistance 2k ohms                      Minimum Power of 0.5W  
Minimum resistance 500 ohms                      Minimum Power of 2W

On the low impedance units care must be taken with the polarity of the monitoring voltage. If an end of line resistor is fitted to a unit the links on the printed circuit boards of all loudspeakers in the line must be cut for the dc blocking capacitors to be in circuit in order to dc monitor the line (see Fig 5).

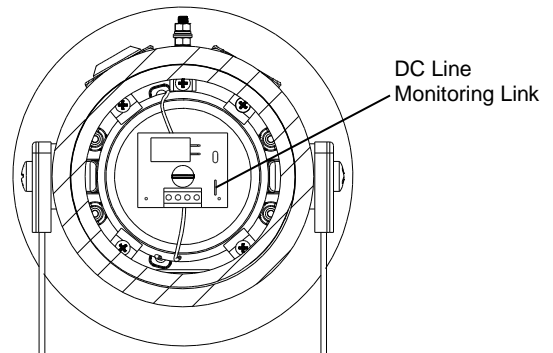

Fig. 5 Low Impedance Line Monitoring Link

## 11) Maintenance, Overhaul and Repair

Maintenance, repair and overhaul of the equipment should only be carried out by suitably qualified personnel in accordance with the current relevant standards:

For ATEX/IECEX or UKEx:

EN60079-19/IEC60079-19

Explosive atmospheres – Equipment repair, overhaul and reclamation

EN 60079-17/IEC60079-17

Explosive atmospheres – Electrical installations inspection and maintenance

Units must not be opened while an explosive atmosphere is present.

If opening the unit during maintenance operations, a clean environment must be maintained and any dust layer removed prior to opening the unit.

Potential electrostatic charging hazard – Clean only with a damp cloth.

# FIRE INSTRUCTION & SERVICE MANUAL

## D1xL1F, D1xL2F & D1xL2H



D1xL1FV100, D1xL2FV100, D1xL2HV100, D1xL1FV725, D1xL2FV725, D1xL2HV725, D1xL1FR008, D1xL2FR008, D1xL2HR008, D1xL1FR016, D1xL2FR016 & D1xL2HR016 are approved for use as Loudspeakers for Fire Alarm Systems:  
 UL1480 (Ed 6)  
 CAN/ULC S-541 (Ed 4)



Attention: Installation must be carried out by an electrician in compliance with the National Electrical Code, NFPA 70, and the National Fire Alarm Signaling Code, NFPA 72 or CSA 22.1 Canadian Electrical Code, Part I, Safety Standard for Electrical Installations, Section 32. / L'installation doit exclusivement être réalisée par du personnel qualifié, conformément au code national d'électricité américain, NFPA 70, et le code national d'alarme incendie et de signalisation NFPA 72 ou CSA 22.1 Code canadien de l'électricité, première partie, norme de sécurité relative aux installations électriques, Section 32



Attention: Disconnect from power source before installation or service to prevent electric shock / Débranchez-le de la source d'alimentation avant l'installation ou l'entretien pour éviter tout choc électrique.



Attention: Fire Alarm Device—Do not paint / Ne pas Peinturer—Dispositif D'Alarme



Attention: Do not change factory applied finishes / Ne pas changer le revêtement applique en usine

- Type 4 / 4X / 3R / 13, IP66
- -55°C to +80°C / -67°F to +176°F
- Units should be mounted using at least 2 of the 3-off/4-off  $\varnothing$ 7mm holes in the mounting bracket.
- The Equipment must not be installed with the horn facing upwards or horizontal.
- If a high IP (Ingress Protection) rating is required then a suitable sealing washer or O-ring must be fitted under any cable gland or blanking device with metric threads.
- Check that the 'O' ring seal is in place before replacing the cover.
- To maintain the enclosure rating, the cable entries must be fitted with suitably rated cable entry and/or blanking devices or suitably sized conduit during installation. If entries are fitted with adaptors they must be suitable for the application.
- Connections are to be made into the terminal blocks using solid or stranded wire, sizes 0.5-2.5mm<sup>2</sup> / AWG 20-14. Wire insulation needs to be stripped 8mm. Wires may be fitted securely with crimped ferrules. Terminal screws need to be tightened down with a tightening torque of 0.45 Nm / 4 Lb-in.
- A single wire with a cross sectional area of up to 2.5mm<sup>2</sup> / AWG14 can be connected to each terminal way. When connecting wires to the terminals great care should be taken to dress the wire so that when the cover is inserted into the chamber the wires do not exert excess pressure on the terminal blocks.
- Units can be located indoor or outdoor wet use, wall or ceiling mounted.

### D1xL1FV725, D1xL2FV725, D1xL2HV725 Wiring Terminals

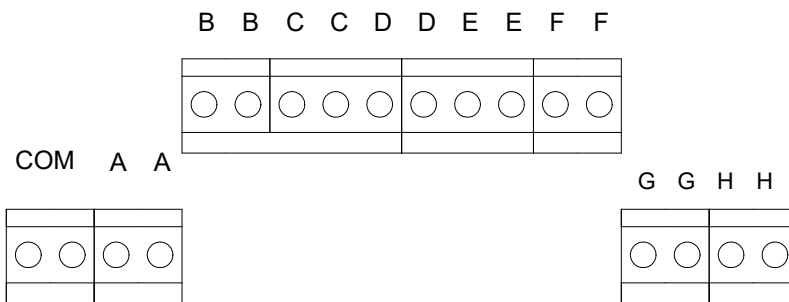

Terminals	D1xL1FV725		D1xL2FV725, D1xL2HV725	
	70.7V	25V	70.7V	25V
COM - A	-	15W	-	25W
COM - B	-	7.5W	-	12.5W
COM - C	15W	5W	25W	6W
COM - D	7.5W	4W	12.5W	4W
COM - E	5W	2W	6W	2W
COM - F	4W	-	4W	1W
COM - G	2W	-	2W	-
COM - H	-	-	1W	-

### D1xL1FV070, D1xL2FV070, D1xL2HV070, D1xL1FV100, D1xL2FV100 & D1xL2HV100 Wiring Terminals

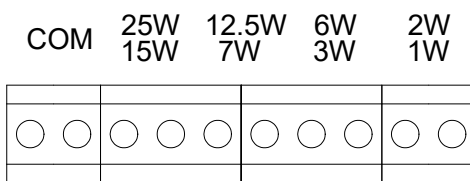

Terminals	D1xL1FV070	D1xL1FV100	D1xL2FV070, D1xL2HV070,	D1xL2FV100, D1xL2HV100
COM – 25W/15W	15W	15W	25W	25W
COM – 12.5W/7W	7W	7W	12.5W	12.5W
COM – 6W/3W	3W	3W	6W	6W
COM – 2W/1W	1W	1.1W	2W	2.1W

# FIRE INSTRUCTION & SERVICE MANUAL

## D1xL1F, D1xL2F & D1xL2H



### Sound Pressure Level

UL1480 Product Data													
Unit Type Code	Input	Power	Max Input	SPL Output (dB(A)) at different Transformer Tappings									
				1W	2W	-	4W	5W	6W	7.5W	12.5W	15W	25W
D1xL1FV725	70V Line	15W	70.7V	-	90.19	-	93.04	95.51	-	98.18	-	100.39	-
	25V Line	15W	25V	-	86.83	-	89.97	92.59	-	97.56	-	99.56	-
D1xL2FV725	70V Line	25W	70.7V	91.17	94.00	-	96.71	-	98.24	-	100.75	-	103.19
	25V Line	25W	25V	87.83	89.42	-	92.27	-	95.45	-	100.06	-	101.00
D1xL2HV725	70V Line	25W	70.7V	91.42	94.10	-	96.93	-	98.27	-	101.03	-	103.29
	25V Line	25W	25V	88.27	89.94	-	93.04	-	95.88	-	100.57	-	101.58
Unit Type Code	Input	Power	Max Input	SPL Output (dB(A)) at different Transformer Tappings									
				1.1W	2.1W	3W	-	-	6W	7.5W	12.5W	15W	25W
D1xL1FV100	100V Line	15W	100V	90.66	-	95.17	-	-	-	98.57	-	100.90	-
D1xL2FV100	100V Line	25W	100V	-	93.86	-	-	-	98.20	-	100.80	-	102.90
D1xL2HV100	100V Line	25W	100V	-	94.16	-	-	-	98.13	-	100.56	-	102.47
D1xL1FR008	8 Ohm	15W	10.95V	100.03									
D1xL1FR016	16 Ohm	15W	15.49V	100.68									
D1xL2FR008	8 Ohm	25W	14.14V	102.25									
D1xL2FR016	16 Ohm	25W	20.00V	102.76									
D1xL2HR008	8 Ohm	25W	14.14V	102.66									
D1xL2HR016	16 Ohm	25W	20.00V	102.68									

CAN/ULC S-541 Product Data													
Unit Type Code	Input	Power	Max Input	SPL Output (dB(A)) at different Transformer Tappings									
				1W	2W	-	4W	5W	6W	7.5W	12.5W	15W	25W
D1xL1FV725	70V Line	15W	70.7V	-	95.60	-	98.36	100.80	-	103.50	-	106.10	-
	25V Line	15W	25V	-	92.32	-	95.50	98.32	-	103.40	-	105.30	-
D1xL2FV725	70V Line	25W	70.7V	97.25	100.10	-	102.80	-	104.70	-	107.20	-	109.70
	25V Line	25W	25V	94.53	96.14	-	99.54	-	102.30	-	107.10	-	108.20
D1xL2HV725	70V Line	25W	70.7V	99.96	102.80	-	105.60	-	107.10	-	109.70	-	111.90
	25V Line	25W	25V	97.43	98.94	-	102.00	-	105.10	-	109.70	-	110.70
Unit Type Code	Input	Power	Max Input	SPL Output (dB(A)) at different Transformer Tappings									
				1.1W	2.1W	3W	-	-	6W	7.5W	12.5W	15W	25W
D1xL1FV100	100V Line	15W	100V	97.30	-	101.70	-	-	-	105.10	-	107.80	-
D1xL2FV100	100V Line	25W	100V	-	101.30	-	-	-	105.70	-	108.10	-	110.50
D1xL2HV100	100V Line	25W	100V	-	103.90	-	-	-	107.60	-	110.30	-	112.50
D1xL1FR008	8 Ohm	15W	10.95V	106.10									
D1xL1FR016	16 Ohm	15W	15.49V	106.30									
D1xL2FR008	8 Ohm	25W	14.14V	109.60									
D1xL2FR016	16 Ohm	25W	20.00V	109.00									
D1xL2HR008	8 Ohm	25W	14.14V	111.50									
D1xL2HR016	16 Ohm	25W	20.00V	112.40									

### Directional Characteristics

CAN/ULC S-541 Directional Characteristics							
Unit Type Code	Rated Angle	Horizontal Axis			Vertical Axis		
		-3dB(A)	-6dB(A)	Reduction @ 90°	-3dB(A)	-6dB(A)	Reduction @ 90°
D1xL1FV100	0°	+/-25	+/-65	-9.1	+/-30	+/-65	-8.8
D1xL1FV725							
D1xL1FR008							
D1xL1FR016							
D1xL2FV100	0°	+/-30	+/-50	-11.4	+/-25	+/-45	-11.4
D1xL2FV725							
D1xL2FR008							
D1xL2FR016							
D1xL2HV100	0°	+/-20	+/-30	-16.2	+/-20	+/-30	-16.3
D1xL2HV725							
D1xL2HR008							
D1xL2HR016							



1	2	3	4	5	6	7	8	9	10
							ISSUE	MOD No.	REASON - INITIAL - DATE
							A		INTRODUCTION D.H 18/11/20
							1		INTRODUCTION RSR 16/03/22
							2	ACN0123	ADDITION OF 70 / 25V VARIANTS RSR 31/03/23

D1xL1V070 & D1xL1V100 Line in Optional Line Monitoring	Config.: 1a	D1xL1V070 & D1xL1V100 Line in Optional Line Monitoring	Config.: 1b	D1xL1V070 & D1xL1V100 Line in Optional Line Monitoring	Config.: 1c	D1xL1V070 & D1xL1V100 Line in Optional Line Monitoring	Config.: 1d
15W: Apply Signal to Common & 15W		7.5W: Apply Signal to Common & 7.5W		3W: Apply Signal to Common & 3W		1W: Apply Signal to Common & 1W	

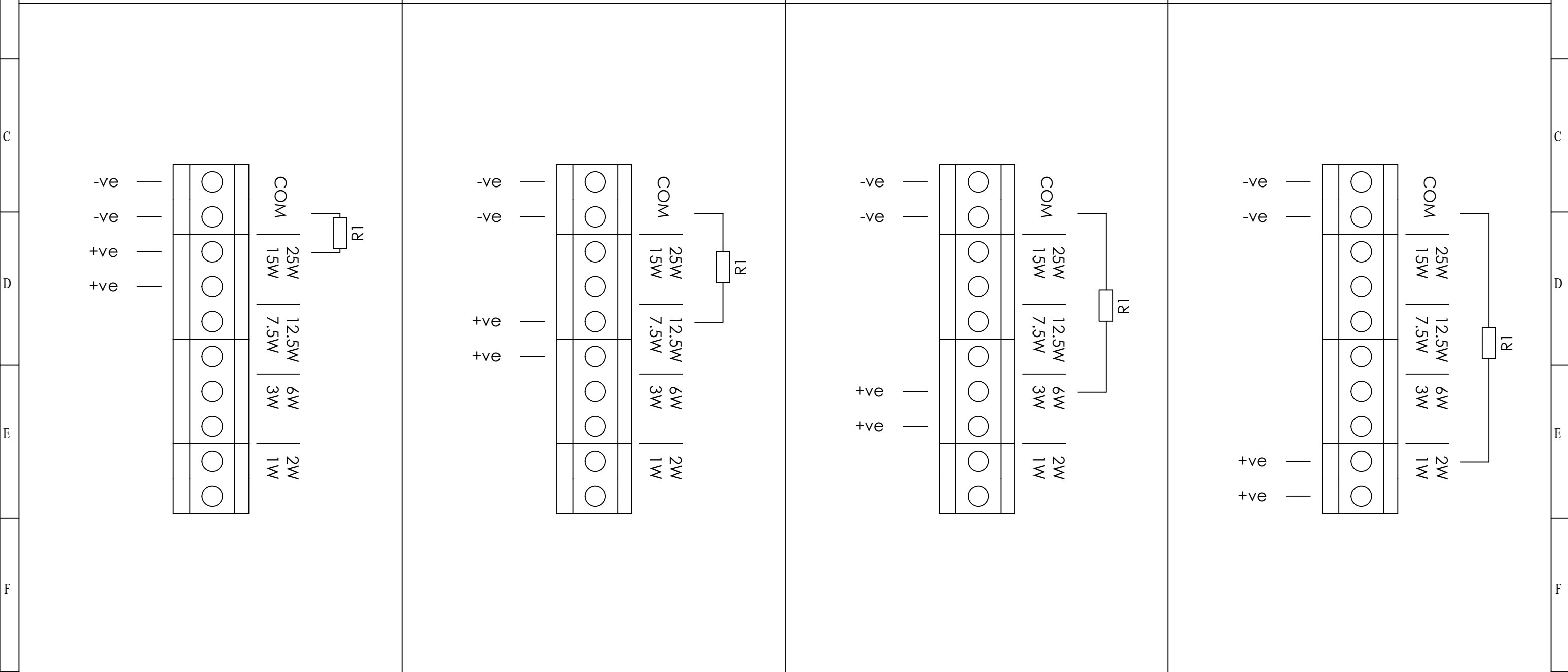

DRAWING TO BS8888:2000 GEOMETRIC TOLERANCES TO ISO1101:1983 LINEAR DIMENSIONAL TOLS ANGULAR DIMENSIONAL TOLS	DRAWN D.HOWGILL	DATE 18/11/20	SURFACE FINISH	WEIGHT (Kg)	THIS DRAWING AND ANY INFORMATION OR DESCRIPTIVE MATTER THEREIN IS COMMUNICATED IN CONFIDENCE AND IS THE COPYRIGHT PROPERTY OF EUROPEAN SAFETY SYSTEMS LTD. NEITHER THE WHOLE OR ANY EXTRACT MAY BE DISCLOSED, LOANED, COPIED OR USED FOR MANUFACTURING OR TENDERING PURPOSES WITHOUT THEIR WRITTEN CONSENT.	 EUROPEAN SAFETY SYSTEMS LTD IMPRESS HOUSE MANSELL ROAD ACTON LONDON W3 7QH WWW.E2S.COM	ALL DIMENSIONS IN MM IF IN DOUBT, ASK - DO NOT SCALE		<b>A3</b>
	CHECKED R.N.POTTS	DATE 18/11/20	MATERIAL	TITLE <b>D1xL1 &amp; D1xL2 LINE IN &amp; LOW IMPEDANCE LOUDSPEAKER WIRING DIAGRAMS</b>					
	APPROVED R.N.POTTS	DATE 18/11/20	ALTERNATIVE MATERIAL	SCALE NTS			SHEET 1 OF 5	DRAWING NUMBER <b>D190-06-201</b>	

1	2	3	4	5	6	7	8	9	10
							ISSUE	MOD No.	REASON - INITIAL - DATE
							A		SEE SHEET 1 D.H 18/11/20
							1		SEE SHEET 1 RSR 16/03/22
							2	ACN0123	SEE SHEET 1 RSR 31/03/23

D1xL2V070 & D1xL2V100 Line in Optional Line Monitoring	Config.: 2a	D1xL2V070 & D1xL2V100 Line in Optional Line Monitoring	Config.: 2b	D1xL2V070 & D1xL2V100 Line in Optional Line Monitoring	Config.: 2c	D1xL2V070 & D1xL2V100 Line in Optional Line Monitoring	Config.: 2d
25W: Apply Signal to Common & 25W		12.5W: Apply Signal to Common & 12.5W		6W: Apply Signal to Common & 6W		2W: Apply Signal to Common & 2W	

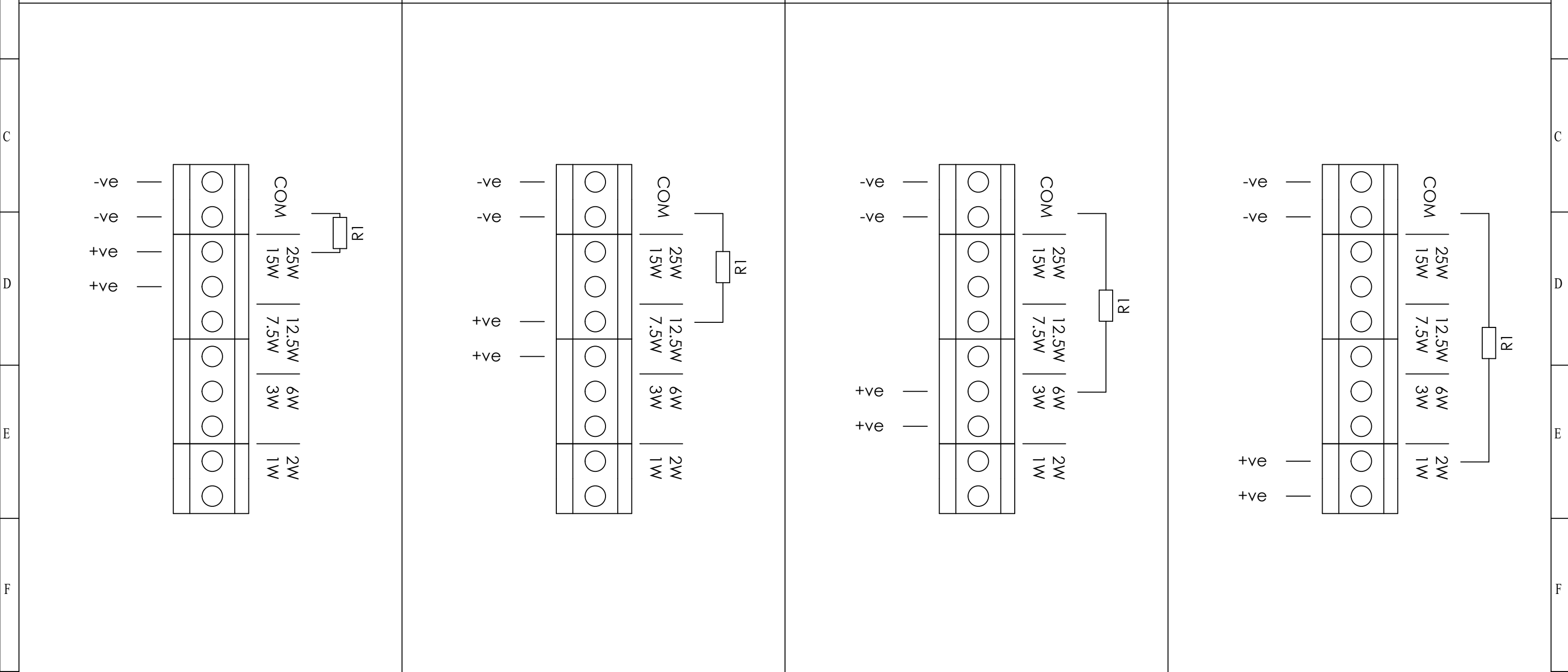

DRAWING TO BS8888:2000 GEOMETRIC TOLERANCES TO ISO1101:1983 LINEAR DIMENSIONAL TOLS ANGULAR DIMENSIONAL TOLS	DRAWN D.HOWGILL	DATE 18/11/20	SURFACE FINISH	WEIGHT (Kg)	THIS DRAWING AND ANY INFORMATION OR DESCRIPTIVE MATTER THEREIN IS COMMUNICATED IN CONFIDENCE AND IS THE COPYRIGHT PROPERTY OF EUROPEAN SAFETY SYSTEMS LTD. NEITHER THE WHOLE OR ANY EXTRACT MAY BE DISCLOSED, LOANED, COPIED OR USED FOR MANUFACTURING OR TENDERING PURPOSES WITHOUT THEIR WRITTEN CONSENT.	warning signals EUROPEAN SAFETY SYSTEMS LTD IMPRESS HOUSE MANSELL ROAD ACTON LONDON W3 7QH WWW.E2S.COM	ALL DIMENSIONS IN MM IF IN DOUBT, ASK - DO NOT SCALE		<b>A3</b>
	CHECKED R.N.POTTS	DATE 18/11/20	MATERIAL	TITLE <b>D1xL1 &amp; D1xL2 LINE IN &amp; LOW IMPEDANCE LOUDSPEAKER WIRING DIAGRAMS</b>					
	APPROVED R.N.POTTS	DATE 18/11/20	ALTERNATIVE MATERIAL	SCALE NTS			SHEET 2 OF 5	DRAWING NUMBER <b>D190-06-201</b>	

OPTIONAL LINE MONITORING RESISTOR, CUSTOMER SUPPLIED,  
 MINIMUM VALUES:  
 500Ω MIN, 2W MIN OR 2KΩ MIN, 0.5W MIN



ISSUE	MOD No.	REASON - INITIAL - DATE
A		SEE SHEET 1 D.H 18/11/20
1		SEE SHEET 1 RSR 16/03/22
2	ACN0123	SEE SHEET 1 RSR 31/03/23

D1xL1R008, D1xL1R016, D1xL2R008, D1xL2R016  
 Low Impedance  
 Config.: 3  
 Optional Line Monitoring  
 Apply Signal to +ve & -ve

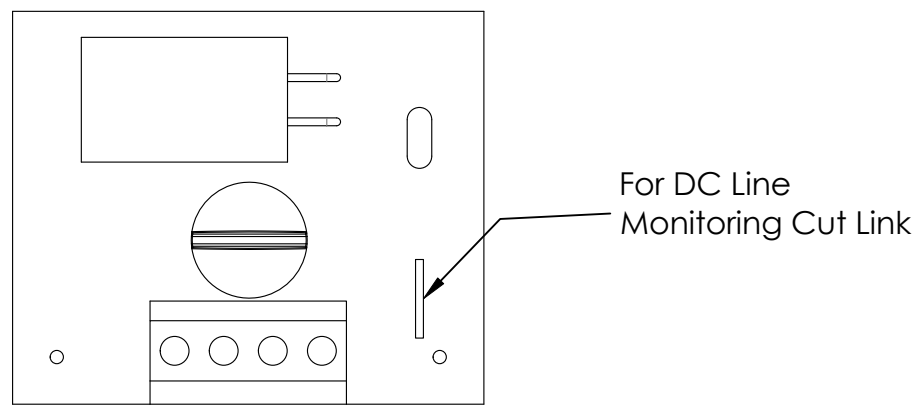
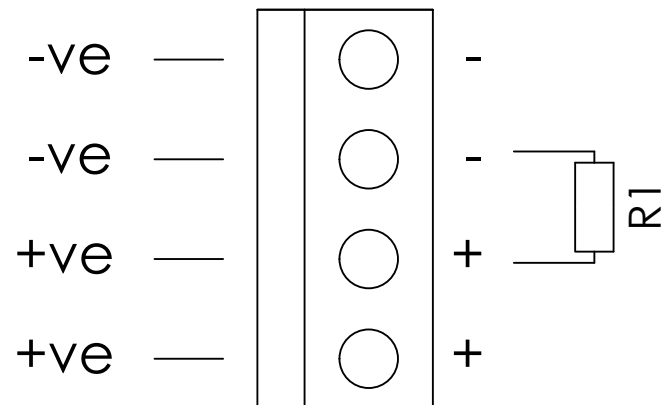

DRAWING TO BS8888:2000  
 GEOMETRIC TOLERANCES TO ISO1101:1983  
 LINEAR DIMENSIONAL TOLS  
 ANGULAR DIMENSIONAL TOLS

STANDARDS  
 D1xL1  
 D1xL2

DRAWN	DATE
D.HOWGILL	18/11/20
CHECKED	DATE
R.N.POTTS	18/11/20
APPROVED	DATE
R.N.POTTS	18/11/20

SURFACE FINISH	WEIGHT (Kg)
MATERIAL	
ALTERNATIVE MATERIAL	

THIS DRAWING AND ANY INFORMATION OR DESCRIPTIVE  
 MATTER THEREIN IS COMMUNICATED IN CONFIDENCE AND  
 IS THE COPYRIGHT PROPERTY OF EUROPEAN SAFETY  
 SYSTEMS LTD. NEITHER THE WHOLE OR ANY EXTRACT MAY  
 BE DISCLOSED, LOANED, COPIED OR USED FOR  
 MANUFACTURING OR TENDERING PURPOSES WITHOUT THEIR  
 WRITTEN CONSENT.

© EUROPEAN SAFETY SYSTEMS LTD.  
 AS PER LATEST DATE OF ISSUE SHOWN ABOVE

  
 warning signals  
 EUROPEAN SAFETY SYSTEMS LTD  
 IMPRESS HOUSE  
 MANSELL ROAD  
 ACTON  
 LONDON W3 7QH  
 WWW.E2S.COM

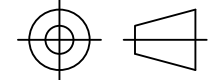
ALL DIMENSIONS IN MM IF IN DOUBT, ASK - DO NOT SCALE			<b>A3</b>
TITLE <b>D1xL1 &amp; D1xL2 LINE IN &amp; LOW IMPEDANCE LOUDSPEAKER WIRING DIAGRAMS</b>			
SCALE NTS	SHEET 3 OF 5	DRAWING NUMBER <b>D190-06-201</b>	

1	2	3	4	5	6	7	8	9	10	
								ISSUE	MOD No.	REASON - INITIAL - DATE
								A		INTRODUCTION D.H 18/11/20
								1		INTRODUCTION RSR 16/03/22
								2	ACN0123	SEE SHEET 1 RSR 31/03/23

D1xL1V725 Line in	Config.: 4a	D1xL1V725 Line in	Config.: 4b	D1xL1V725 Line in	Config.: 4c	D1xL1V725 Line in	Config.: 4d	D1xL1V725 Line in	Config.: 4e
Optional Line Monitoring		Optional Line Monitoring		Optional Line Monitoring		Optional Line Monitoring		Optional Line Monitoring	

15W: 25V: Apply Signal to Common & A 70V: Apply Signal to Common & C	7.5W: 25V: Apply Signal to Common & B 25V: Apply Signal to Common & D	5W: 25V: Apply Signal to Common & C 70V: Apply Signal to Common & E	4W: 25V: Apply Signal to Common & D 70V: Apply Signal to Common & F	2W: 25V: Apply Signal to Common & E 70V: Apply Signal to Common & G
--	---	---	---	---

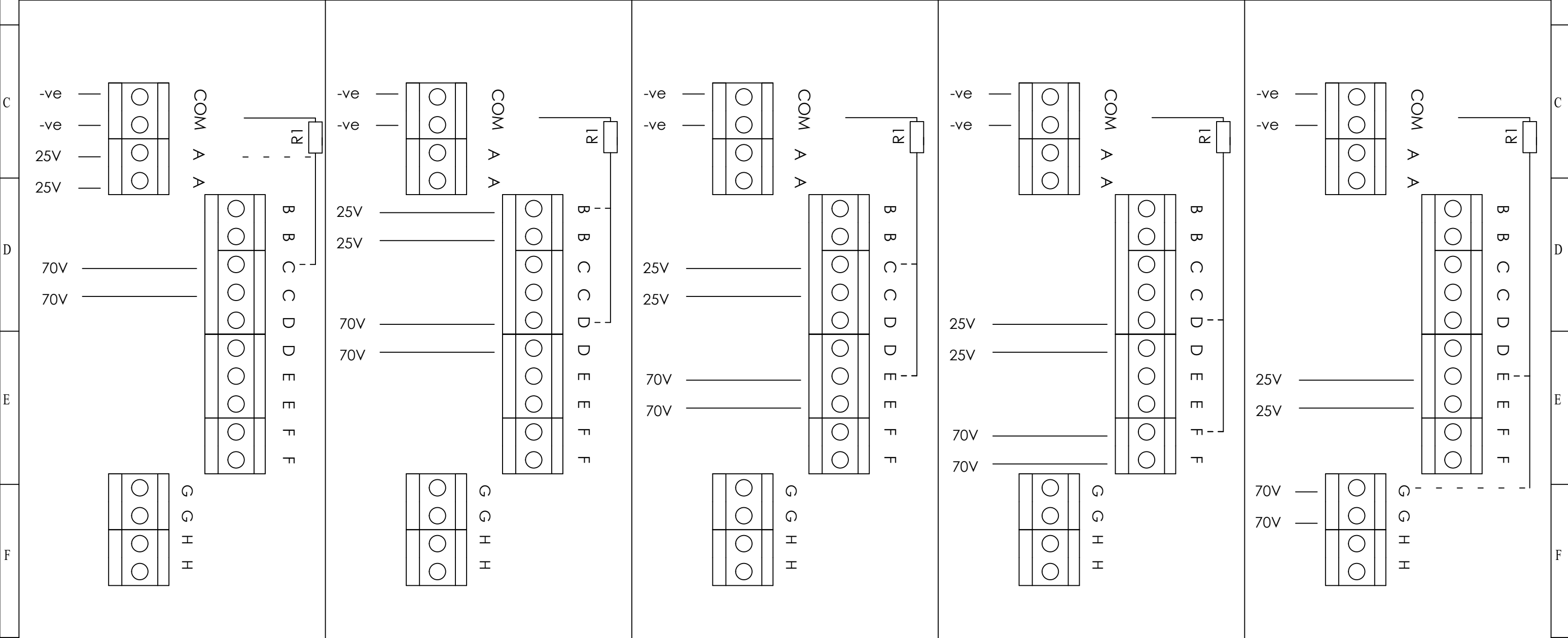

DRAWING TO BS8888:2000 GEOMETRIC TOLERANCES TO ISO1101:1983 LINEAR DIMENSIONAL TOLS ANGULAR DIMENSIONAL TOLS	DRAWN	DATE	SURFACE FINISH	WEIGHT (Kg)	THIS DRAWING AND ANY INFORMATION OR DESCRIPTIVE MATTER THEREIN IS COMMUNICATED IN CONFIDENCE AND IS THE COPYRIGHT PROPERTY OF EUROPEAN SAFETY SYSTEMS LTD. NEITHER THE WHOLE OR ANY EXTRACT MAY BE DISCLOSED, LOANED, COPIED OR USED FOR MANUFACTURING OR TENDERING PURPOSES WITHOUT THEIR WRITTEN CONSENT.	 EUROPEAN SAFETY SYSTEMS LTD IMPRESS HOUSE MANSELL ROAD ACTON LONDON W3 7QH WWW.E2S.COM	ALL DIMENSIONS IN MM			<b>A3</b>
	CHECKED	DATE					IF IN DOUBT, ASK - DO NOT SCALE			
	APPROVED	DATE					TITLE <b>D1xL1 &amp; D1xL2 LINE IN &amp; LOW IMPEDANCE LOUDSPEAKER WIRING DIAGRAMS</b>			
STANDARDS <b>D1xL1</b> <b>D1xL2</b>	R.N.POTTS	18/11/20	ALTERNATIVE MATERIAL		© EUROPEAN SAFETY SYSTEMS LTD. AS PER LATEST DATE OF ISSUE SHOWN ABOVE		SCALE	SHEET	DRAWING NUMBER	
	R.N.POTTS	18/11/20					NTS	4 OF 5	<b>D190-06-201</b>	

1	2	3	4	5	6	7	8	9	10	
								ISSUE	MOD No.	REASON - INITIAL - DATE
								A		INTRODUCTION D.H 18/11/20
								1		INTRODUCTION RSR 16/03/22
								2	ACN0123	SEE SHEET 1 RSR 31/03/23

D1xL2V725 Line in	Config.: 5a	D1xL2V725 Line in	Config.: 5b	D1xL2V725 Line in	Config.: 5c	D1xL2V725 Line in	Config.: 5d	D1xL2V725 Line in	Config.: 5e	D1xL2V725 Line in	Config.: 5f
Optional Line Monitoring		Optional Line Monitoring		Optional Line Monitoring		Optional Line Monitoring		Optional Line Monitoring		Optional Line Monitoring	
25W: 25V: Apply Signal to Common & A 70V: Apply Signal to Common & C		12.5W: 25V: Apply Signal to Common & B 70V: Apply Signal to Common & D		6W: 25V: Apply Signal to Common & C 70V: Apply Signal to Common & E		4W: 25V: Apply Signal to Common & D 70V: Apply Signal to Common & F		2W: 25V: Apply Signal to Common & E 70V: Apply Signal to Common & G		1W: 25V: Apply Signal to Common & F 70V: Apply Signal to Common & H	

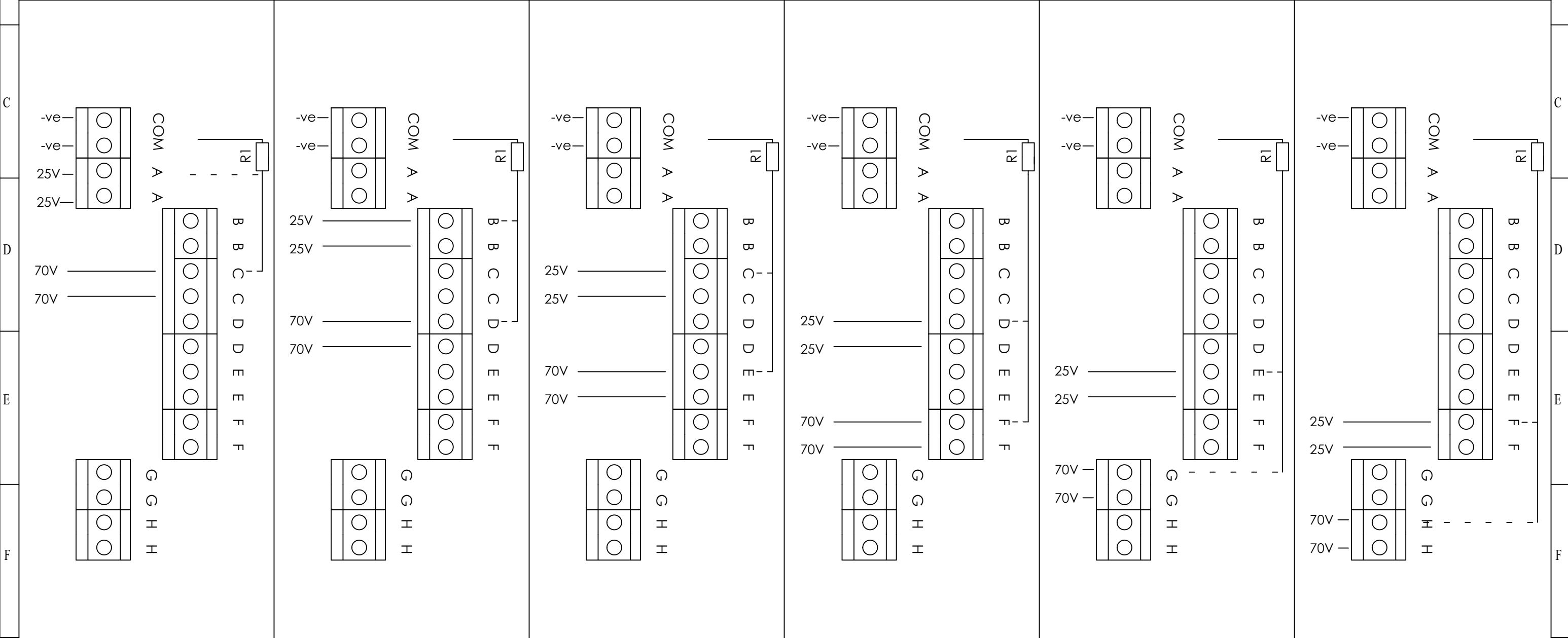

DRAWING TO BS8888:2000 GEOMETRIC TOLERANCES TO ISO1101:1983 LINEAR DIMENSIONAL TOLS ANGULAR DIMENSIONAL TOLS	DRAWN	DATE	SURFACE FINISH	WEIGHT (Kg)	THIS DRAWING AND ANY INFORMATION OR DESCRIPTIVE MATTER THEREIN IS COMMUNICATED IN CONFIDENCE AND IS THE COPYRIGHT PROPERTY OF EUROPEAN SAFETY SYSTEMS LTD. NEITHER THE WHOLE OR ANY EXTRACT MAY BE DISCLOSED, LOANED, COPIED OR USED FOR MANUFACTURING OR TENDERING PURPOSES WITHOUT THEIR WRITTEN CONSENT.	warning signals EUROPEAN SAFETY SYSTEMS LTD IMPRESS HOUSE MANSELL ROAD ACTON LONDON W3 7QH WWW.E2S.COM	ALL DIMENSIONS IN MM			<b>A3</b>
	D.HOWGILL	18/11/20					IF IN DOUBT, ASK - DO NOT SCALE			
	CHECKED	DATE	MATERIAL				TITLE <b>D1xL1 &amp; D1xL2 LINE IN &amp; LOW IMPEDANCE          LOUDSPEAKER WIRING DIAGRAMS</b>			
	R.N.POTTS	18/11/20					ALTERNATIVE MATERIAL		SCALE	SHEET
STANDARDS	APPROVED	DATE			© EUROPEAN SAFETY SYSTEMS LTD. AS PER LATEST DATE OF ISSUE SHOWN ABOVE	NTS	5 OF 5	<b>D190-06-201</b>		
<b>D1xL1</b> <b>D1xL2</b>	R.N.POTTS	18/11/20								

# EU Declaration of Conformity



Manufacturer: European Safety Systems Ltd.  
Impress House, Mansell Road, Acton  
London, W3 7QH  
United Kingdom

Authorised Representative: E2S Warnsignaltechnik UG  
Charlottenstrasse 45-51  
72764 Reutlingen  
Germany

Equipment Type: D1xS1, D1xS2  
D1xL1, D1xL2  
D1xC1X05, D1xC1X10, D1xC2X05, D1xC2X10  
D1xB2XH1, D1xB2XH2

---

Directive 2014/34/EU: Equipment and Protective Systems for use in Potentially Explosive Atmospheres (ATEX) - D1xS1, D1xS2, D1xL1, D1xL2, D1xC1X05, D1xC1X10, D1xC2X05 and D1xC2X10 only

Notified Body for EU type Examination (Module B): UL International Demko A/S  
Borupvang 5A  
2750 Ballerup  
Denmark

EU-type Examination Certificate (Module B): DEMKO 19 ATEX 2141X

Notified Body for Quality Assurance Notification / Conformity to EU-type based on quality assurance of the production process (Module D): Sira Certification Service  
Notified Body No.: 2813  
Unit 6, Hawarden Industrial Park, Hawarden, Deeside, CH5 3US, UK

Quality Assurance Notification (Module D): SIRA 05 ATEX M342

Provisions fulfilled by the equipment: II 2G Ex db IIC T6...T3 GB  
II 2D Ex tb IIIC T82°C...145°C Db

Standards applied: EN 60079-0:2018  
EN 60079-1:2014  
EN60079-31:2014

Regulation EU No. 305/2011: Construction Products Regulation (CPR) – D1xS1FDC024\*\*\*A1R & D1xS1FDC024\*\*\*A1G only – tones 1, 2, 5, 8, 40, 44, 53 only

Notified Product Certification Body for Certificate of Constancy of Performance or EC Type Examination Certificate and continuous surveillance, assessment and evaluation of factory production control: BRE Global Assurance (Ireland) Limited  
Notified Body No.: 2831  
DCU Alpha, Old Finglas Road, Glasnevin, Dublin, D11 KXN4

Certificate of Constancy of Performance or EC Type Examination Certificate: 2831-CPR-F4858

Standards applied: EN 54-3:2001 + A1:2002 + A2:2006

Directive 2014/30/EU: Electromagnetic Compatibility Directive (EMC)

Standards applied: EN 61000-6-1:2007  
EN 61000-6-2:2005  
EN 61000-6-3:2007 / A1:2011 / AC: 2012  
EN 61000-6-4:2007 / A1: 2011

Directive 2014/35/EU: Low Voltage Directive (LVD)

Standards applied: EN 60947-1:2007 + A2:2014

# EU Declaration of Conformity



Directive 2011/65/EU: Restriction of the use of certain hazardous substances in electrical and electronic equipment (RoHS)

The product and all the components contained within it are in accordance with the restriction of the use of hazardous substances in electrical and electronic equipment, including amendment by Directive 2015/863/EU.

Regulation (EC) 1907/2006: Registration, Evaluation, Authorisation and Restriction of Chemicals (REACH)

The product and all the components contained within it are free from substances of very high concern.

Other Standards and Regulations

EN 60529:1992+A2:2013 - Degrees of protection provided by enclosures (IP code) – enclosure rated IP66/67

---

On behalf of European Safety Systems Ltd., I declare that, on the date the equipment accompanied by this declaration is placed on the market, the equipment conforms with all technical and regulatory requirements of the above listed directives, regulations and standards.

This Declaration is issued under the sole responsibility of the manufacturer.

A handwritten signature in black ink, appearing to read 'Martin Streetz'.

Martin Streetz  
Quality Assurance Manager

Document No.: DC-067\_Issue\_J  
Date and Place of Issue: London, 01/09/2023

**Manufacturer:** European Safety Systems Ltd.  
 Impress House, Mansell Road, Acton  
 London, W3 7QH  
 United Kingdom

**Equipment Type:** D1xS1, D1xS2  
 D1xL1, D1xL2  
 D1xC1X05, D1xC1X10, D1xC2X05, D1xC2X10

Directive UKSI 2016:1107 (as amended by UKSI 2019:696) – Schedule 3A, Part 1 : Product or Protective System Intended for use in Potentially Explosive Atmospheres (UKCA)

Notified Body for UK type Examination (Module B):	UL International (UK) Ltd Notified Body No.: 0843 Unit 1-3 Horizon Kingsland Business Park, Wade Road, Basingstoke, Hampshire RG24 8AH UK
UK-type Examination Certificate (Module B):	UL21UKEX2132X
Notified Body for Quality Assurance Notification / Conformity to EU-type based on quality assurance of the production process (Module D):	Sira Certification Service Notified Body No.: 0518 Rake Lane, Eccleston, Chester CH4 9JN, UK
Quality Assurance Notification (Module D):	CSAE 22UKQAN0046
Provisions fulfilled by the equipment:	II 2G Ex db IIC T6...T3 GB II 2D Ex tb IIIC T82°C...145°C Db
Standards applied:	EN 60079-0:2018 EN 60079-1:2014 EN60079-31:2014

Directive 2014/30/EU: Electromagnetic Compatibility Directive (EMC)

Standards applied:	EN 61000-6-1:2007 EN 61000-6-2:2005 EN 61000-6-3:2007 / A1:2011 / AC: 2012 EN 61000-6-4:2007 / A1: 2011
--------------------	--

Regulation EU No. 305/2011: Construction Products Regulation (CPR) – D1xS1FDC024\*\*\*A1R & D1xS1FDC024\*\*\*A1G only – tones 1, 2, 5, 8, 40, 44, 53 only

Notified Product Certification Body for Certificate of Constancy of Performance or EC Type Examination Certificate and continuous surveillance, assessment and evaluation of factory production control:	BRE Global Limited Notified Body No.: 0832 Bucknalls Lane, Garston, Watord, Hertfordshire, UK, WD25 9XX
Certificate of Constancy of Performance or EC Type Examination Certificate:	0832-UKCA-CPR-F1782
Standards applied:	EN 54-3:2001 + A1:2002 + A2:2006

Directive 2014/35/EU: Low Voltage Directive (LVD)

Standards applied:	EN 60947-1:2007 + A2:2014
--------------------	---------------------------

Directive 2011/65/EU: Restriction of the use of certain hazardous substances in electrical and electronic equipment (RoHS)

The product and all the components contained within it are in accordance with the restriction of the use of hazardous substances in electrical and electronic equipment, including amendment by Directive 2015/863/EU.

Regulation (EC) 1907/2006: Registration, Evaluation, Authorisation and Restriction of Chemicals (REACH)

The product and all the components contained within it are free from substances of very high concern.



# UKCA Declaration of Conformity



## Other Standards and Regulations

EN 60529:1992+A2:2013 - Degrees of protection provided by enclosures (IP code) – enclosure rated IP66/67

---

On behalf of European Safety Systems Ltd., I declare that, on the date the equipment accompanied by this declaration is placed on the market, the equipment conforms with all technical and regulatory requirements of the above listed directives, regulations and standards.

This Declaration is issued under the sole responsibility of the manufacturer.

A handwritten signature in black ink, appearing to read 'Martin Streetz'.

Martin Streetz  
Quality Assurance Manager

Document No.: DC-097\_Issue\_B  
Date and Place of Issue: London, 01/09/2023

Page left Intentionally blank

Page left Intentionally blank

Page left Intentionally blank