

AL100SONTEL Telephone Alarm & Xenon Strobe

The AL100SONTEL is a compact, high output, 100dB(A) telephone initiated alarm sounder and 5 Joule Xenon beacon.

Features

- Continuously rated
- Stainless steel fixings
- Unit can be mounted using external lugs or internal fixing positions
- Dual M20 clearance cable entries

Approvals

- CE
- UKCA
- EAC: CU TR 04/2011 CU TR 20/2011
- Russian Maritime Register of Shipping



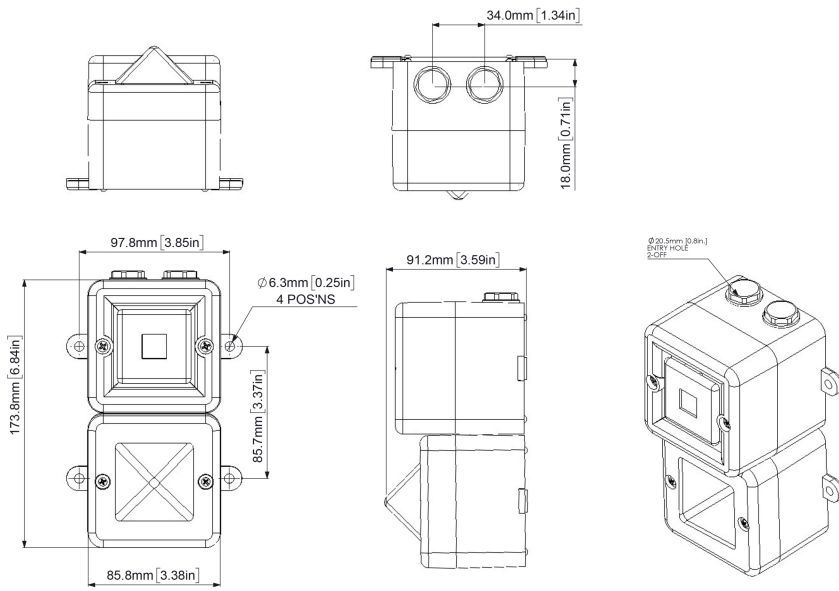

Specification

Sounder:	
Nominal output:	100dB(A) @ 1m +/- 3dB [91dB(A) @ 10ft/3m]
No. of tones:	3
Tone 1	Siren Tone
Tone 2	Alternating tone
Tone 3	Sweeping tone
Volume control:	Max. 100dB(A); Min. 90dB(A)
Effect. range:	32m/105ft @ 1KHz
Beacon:	
Energy:	5 Joules (5Ws)
Flash rate:	1Hz (60 fpm)
Peak Candela:	500,000 cd - calculated from energy (J)
Effect. Intensity cd:	250 cd - calculated from energy (J)
Peak Candela:	78,801 cd* - measured ref. to I.E.S.
Effect. Intensity cd:	196 cd* - measured ref. to I.E.S.
Lens colours:	Amber, Blue, Clear, Green, Opal, Red & Yellow
Tube life:	Emissions are reduced to 70% after 5 million flashes
General:	
Sounder Supply:	Direct power from telephone line (REN 1)
Beacon Supply:	230V ac (telephone initiated)
Ingress protection:	IP66
Enclosure matl:	High impact UL94 V0 & 5VA FR ABS
Colour:	Red (RAL3000), grey (RAL7038) & white.
Cable entries:	3 x M20 clearance gland knockouts in side & back
Terminals:	0.5 to 2.5mm ² cables.
Operating temp:	-40 to +66°C [-40° to +151°F]
Storage temp:	-40 to +70°C [-40° to +158°F]
Relative humidity:	90% at 20°C [68°F]
Weight:	0.46kg/1.01lbs
Candela measurements representative of performance with clear lens at optimum voltage.	
SPL data +/-3dB(A). Measured at optimum voltage	

Part Codes

Variable:	Identifier:	Description:
Product type:	AL100SONTEL	Telephone Initiated Alarm Horn Sounder & Xenon Strobe
Voltage:	230	230Vac 50/60Hz
Back box/cable entries:	M	Back box with mounting lugs - 2 x M20 clearance entries: [e]
Stopping plug material:	A	ABS
Equip. tag/Duty label:	0	No equip. tag or Duty label
	1	316 (A4) St/St Equip. tag/Duty label
	2	Metalised Polyester Equip. tag/Duty label
Product version:	A	RMRS, EAC, CE, UKCA [v]
Product option:	1	Standard product
	X	Custom configuration - contact E2S
	T	Conformal coated - tropicalised
Enclosure:	[x]	R Red (RAL 3000)
		G Grey (RAL 7038)
		W White
Lens colour:	[y]	A Amber
		B Blue
		C Clear
		G Green
		M Magenta
		R Red
		Y Yellow