

STExS1F Alarm Horn Sounder

The STExS1F is a UL, cUL, IECEx and ATEX certified alarm horn sounder featuring a re-entrant flare horn. The robust 316L stainless steel enclosure is approved for Zone 1, 2, 21 & 22 explosion proof signalling applications.

Featuring 64 alarm tone sounds, each of the available 4 stage/channels can be remotely triggered. Class D amplification provides a high sound output at optimum operating current. The threaded flameproof joint, multiple cable entries and duplicated, pluggable termination simplifies both installation and routine maintenance. SIL1 & SIL2 Route 2H compliant to IEC61508 (2010) as standard, with optional diagnostic module for Route 1H SIL2 compliance. DNV type approved for exposed locations.

Features

- Maximum sound pressure level output of 115dB(A)
- Choice of 64 alarm tone frequencies
- 4 remotely selectable alarm stages/channels
- Positive or negative line stage/channel switching
- Automatic synchronisation on multi-sounder system
- Ratchet adjustable 316 stainless steel bracket
- Triple cable entries
- Available with custom tone configurations and frequencies
- Robust corrosion proof 316L stainless steel enclosure
- DNV type approved IEC 60945 & DNVGL-CG-0339

Approvals

- UL/cUL - File ref: E230764
- IECEx ULD 16.0017X
- ATEX DEMKO 16 ATEX 1466X
- UKCA certificate: UL21UKEX2019X
- TR-CU Ex EAC certificate: RU C-GB.HA65.B.01252_21
- INMETRO IEx 20.0156X
- DNV type approved: TAA00001JN
- SIL1 & SIL2 compliant to IEC61508 (2010)

Coding

- NEC / Class / Zone
Class I Zone 1 AEx db IIC T5 Ta -50°C to +70°C
Class I Zone 1 AEx db IIC T6 Ta -50°C to +65°C
- CEC / Class / Zone
Class I Zone 1 Ex db IIC T5 Ta -50°C to +70°C
Class I Zone 1 Ex db IIC T6 Ta -50°C to +65°C
- NEC / CEC Class / Div
Class I Div 2 ABCD T5 Ta -50°C to +70°C
Class I Div 2 ABCD T6 Ta -50°C to +65°C
- IECEx / ATEX
II 2G Ex db IIC Gb T5 Ta -50°C to +70°C
II 2G Ex db IIC Gb T6 Ta -50°C to +65°C
II 2D Ex tb IIIC Db T85°C Ta -50°C to +70°C



Specification

Maximum output:	115dB(A) @ 1 m +/- 3dB [106dB(A) @ 10ft/3m +/- 3dB]
Nominal output:	110dB(A) @ 1m +/- 3dB [101dB(A) @ 10ft/3m] +/- 3dB
No. of tones:	64 (UK00A / PFEER compliant)
No. of stages:	4
Volume control:	Full range
Effective range:	125m/410ft @ 1KHz
Voltages DC:	24Vdc (11.5-54Vdc)
Voltages AC:	230Vac (100-240Vac)
In-rush:	815mA within 4ms @ 24Vdc
Stage switching:	DC units: positive or negative AC units: common supply line
Safety Integrity Level:	Product version A: SIL1 and SIL2 Route 2H Product version S: SIL2 Route 1H with diagnostics SFF: >99% See install manual for reliability & functional safety data
Ingress protection:	EN60529: IP66
Enclosure material:	316L Stainless Steel
Enclosure colour:	Red
Enclosure finish:	Chromate & powder coated finish
Cable entries:	3 x M20x1.5mm Stopping plugs included
Stopping plugs:	Stainless Steel
Terminals:	0.5 – 2.5mm ² (20-14 AWG) Pluggable & duplicated terminals
Line monitoring:	Diode polarized for use in supervised circuits Blocking diode for reverse polarity monitoring
Ground/Earth stud:	M5
Line monitoring:	Blocking diode included EOL Min. 500 Ohm 2W, or 3k3 Ohm 0.5W resistor or diode (DC versions) can be fitted
Enclosure volume:	<2 litres
Installation temp:	-50° to +70°C (-58°F to +158°F)
Storage temp:	-50° to +70°C (-58°F to +158°F)
Relative humidity:	99%
MTBF DC:	93.92 years / 822,706 hours – MIL 217
MTBF AC:	46.66 years / 408,508 hours – MIL 217
Weight:	6.25kg/13.75lbs

Part Codes

Part Code:	Identifier:	Description:
Product type:	STExS1	STExS1 alarm horn sounder
Horn type:	F	Flare re-entrant horn
Voltage:	DC024 AC230	11.5-54Vdc 100-240Vac
Cable entries:[e]	A B C D E F G	3 x M20x1.5mm 2 x 1/2" NPT – adaptors 2 x 3/4" NPT – adaptors 2 x M25x1.5mm – adaptors 1 x 1/2" NPT – adaptor 1 x 3/4" NPT – adaptor 1 x M25x1.5mm – adaptor
Stopping plug/ adaptor material: [m]	S	Stainless steel
Bracket material: [s]	1 3	A4 316 Stainless Steel A4 316 St/St with Equip. Tag
Product version: [v]A	S	UL, cUL, ULC, IECEx, ATEX, DNV, Ex EAC, INMETRO – SIL1 & SIL2 Route 2H UL, cUL, ULC, IECEx, ATEX, Ex EAC, INMETRO – SIL2 Route 1H with diagnostics SFF: >99%
Product option: [o]	1 Z X Y K V	Standard product Custom alarm tone software – contact E2S Custom configuration – contact E2S Stage control Config. 4 Stage control Config. 5 (DC) and Config. 2 (AC) Stage control Config. 6
Enclosure colour: [x]	R S	Red Special – contact E2S for alternative enclosure colours

Accessories:

SP65-0001-A4	Pole Mount Bracket Kit St/St A4 (316)
SP65-0003-A4	Sunshade – St/St A4 (316)

Alarm stage control:

Please review the installation manual and wiring schematics for remote stage control and EOL resistor monitoring configuration options:

Config. 1 [DC]:	Factory default. Common negative, positive switching. Up to 4 Alarm Stages. EOL monitoring Alarm Stage 1 only
Config. 2 [DC]:	User setting. Common positive, negative switching. Up to 4 Alarm Stages. EOL monitoring Alarm Stage 1 only
Config. 3 [DC]:	User setting. Common negative, positive switching activation of Alarm Stages 1 & 2 with EOL on both stages. Reverse polarity monitoring
Config. 4 [DC]:	Product option 'Y'. Independent activation of Alarm Stages 1 & 2 with EOL on both stages. Forward polarity monitoring
Config. 5 [DC]:	Product option 'K'. Horn continuously powered. Voltage free activation of up to 3 alarm stages
Config. 6 [DC]:	Product option 'V'. Independent activation of up to 4 Alarm Stages with EOL on all stages. Forward polarity monitoring
Config. 1 [AC]:	Factory default. Up to 4 Alarm Stages. Stage 1 activated at power on. Stages 2, 3 and 4 via volt free contacts
Config. 2 [AC]:	Product option 'K'. Horn continuously powered. Voltage free activation of up to 3 alarm stages

Current Consumption

Nominal Voltage:	Voltage range:	Nominal current:	Max. current:	In-rush:
12Vdc	11.5-54Vdc	221mA	221mA	-
24Vdc	11.5-54Vdc	185mA	221mA	815mA <4ms
48Vdc	11.5-54Vdc	115mA	221mA	-
115Vac 50/60Hz	100-260V ac	73mA	80mA	-
230Vac 50/60Hz	100-260V ac	48mA	80mA	-

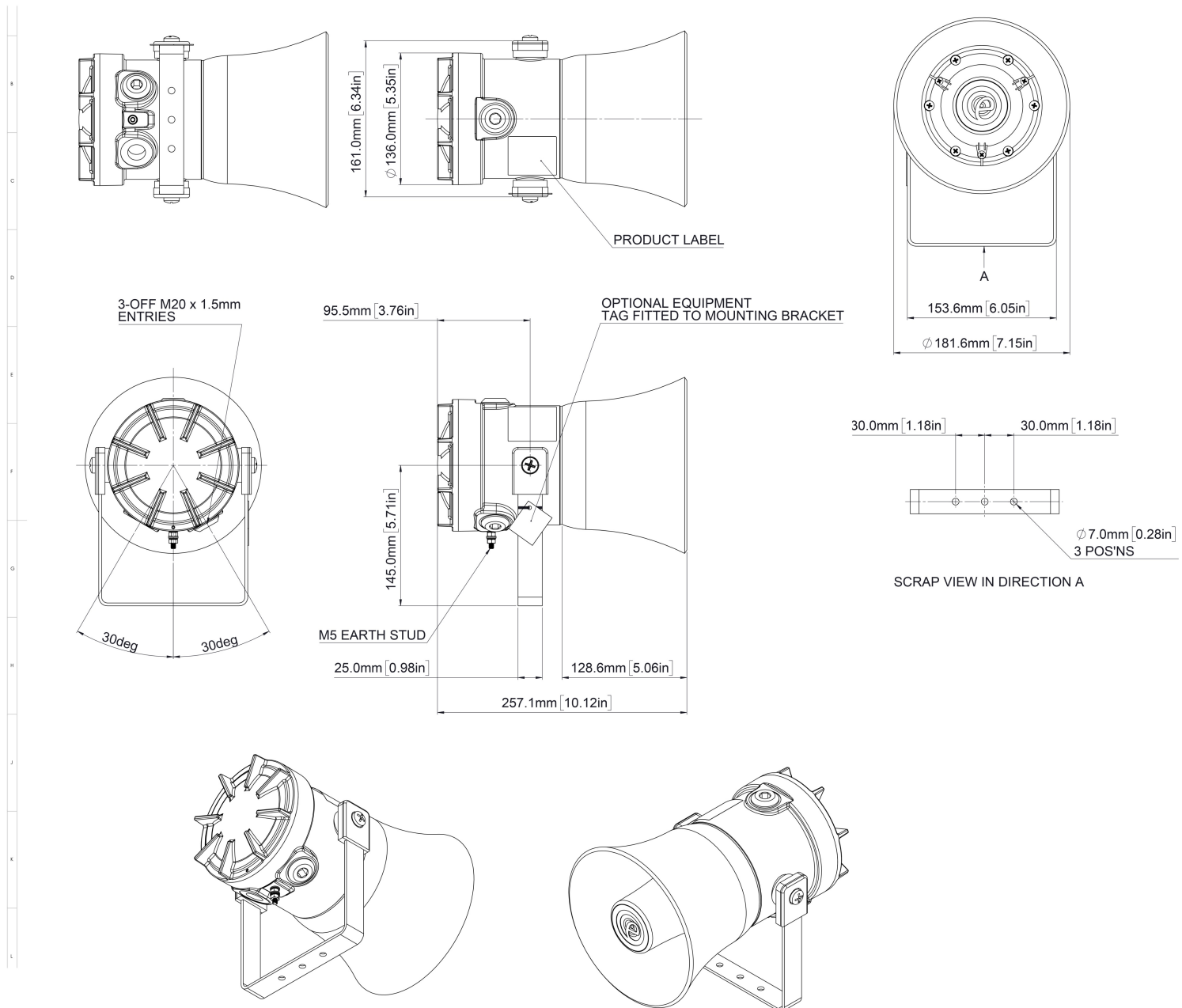

Assemblies

The STExS1F is available as a plated assembly configured with Xenon strobe or LED beacons with or without a STExJ2 Ex d junction box. Contact E2S for further information.

Tone table

S 1	Description	S 2	S 3	S 4	S 1	Description	S 2	S 3	S 4
T 1	1000 Continuous - PFEER Toxic Gas	Any	T 2	T 44	T 33	800 (0.25s on, 1.00s off) Intermittent	Any	T 24	T 8
T 2	1200/500 @ 1Hz Sweeping - DIN / PFEER P.T.A.P.	Any	T 3	T 44	T 34	800 @ 2Hz (0.25s on, 0.25s off) - IMO code 3...	Any	T 24	T 8
T 3	1000 @ 0.5Hz (1s on, 1s off) Intermittent - P...	Any	T 2	T 44	T 35	1000 @ 1Hz (0.50s on, 0.50s off) Intermittent	Any	T 24	T 8
T 4	1.4KH-1.6KHz 1s, 1.6KHz-1.4KHz 0.5s - NF C 48...	Any	T 24	T 1	T 36	2400 @ 1Hz (0.50s on, 0.50s off) Intermittent	Any	T 24	T 8
T 5	544(100mS)/440 (400mS) - NF S 32-001	Any	T 19	T 1	T 37	2900 @ 5Hz (0.10s on, 0.10s off) Intermittent	Any	T 24	T 8
T 6	1500/500 - (0.5s on , 0.5s off) x3 + 1s gap - ...	Any	T 44	T 1	T 38	363/518 @ 1Hz (0.50s / 0.50s) Alternating	Any	T 8	T 19
T 7	500-1500Hz Sweeping 2 sec on 1 sec off - AS4428	Any	T 44	T 1	T 39	450/500 @ 2Hz (0.25s / 0.25s) Alternating	Any	T 8	T 19
T 8	500/1200Hz @ 0.26Hz(3.3s on, 0.5s off) - NEN ...	Any	T 24	T 35	T 40	554/440 @ 1Hz (0.50s / 0.50s) Alternating	Any	T 24	T 19
T 9	1000 (1s on, 1s off)x7 + (7s on, 1s off) - IM...	Any	T 34	T 1	T 41	554/440 @ 0.65Hz (0.76s / 0.76s) Alternating	Any	T 8	T 19
T 10	1000 (1s on, 1s off)x7 + (7s on, 1s off) - IM...	Any	T 34	T 1	T 42	561/760 @ 0.83Hz (0.60s / 0.60s) Alternating	Any	T 8	T 19
T 11	420(0.5s on, 0.5s off)x3 + 1s gap - ISO 8201 ...	Any	T 1	T 8	T 43	780/600 @ 0.96Hz (0.52s / 0.52s) Alternating	Any	T 8	T 19
T 12	1000(0.5s on, 0.5s off)x3 + 1s gap - ISO 8201...	Any	T 1	T 8	T 44	800/1000 @ 2Hz (0.25s / 0.25s) Alternating	Any	T 24	T 19
T 13	422/775 - (0.85 on, 0.5 off) x3 + 1s gap - ...	Any	T 1	T 8	T 45	970/800 @ 2Hz (0.25s / 0.25s) Alternating	Any	T 8	T 19
T 14	1000/2000 @ 1Hz - Singapore	Any	T 3	T 35	T 46	800/1000 @ 0.875Hz (0.57s / 0.57s) Alternating	Any	T 24	T 19
T 15	300 Continuous	Any	T 24	T 35	T 47	2400/2900 @ 2Hz (0.25s / 0.25s) Alternating	Any	T 24	T 19
T 16	440 Continuous	Any	T 24	T 35	T 48	500/1200 @ 0.3Hz (1.67s / 1.67s) Sweeping	Any	T 24	T 12
T 17	470 Continuous	Any	T 24	T 35	T 49	560/1055 @ 0.18Hz (2.73s / 2.73s) Sweeping	Any	T 24	T 12
T 18	500 Continuous - IMO code 2 (Low)	Any	T 24	T 35	T 50	560/1055 @ 3.3Hz (0.15s / 0.15s) Sweeping	Any	T 24	T 12
T 19	554 Continuous	Any	T 24	T 35	T 51	600/1250 @ 0.125Hz (4s / 4s) Sweeping	Any	T 24	T 12
T 20	660 Continuous	Any	T 24	T 35	T 52	660/1200 @ 1Hz (0.50s / 0.50s) Sweeping	Any	T 24	T 12
T 21	800 Continuous - IMO code 2 (High)	Any	T 24	T 35	T 53	800/1000 @ 1Hz (0.50s / 0.50s) Sweeping	Any	T 24	T 12
T 22	1200 Continuous	Any	T 24	T 35	T 54	800/1000 @ 7Hz (0.07s / 0.07s) Sweeping	Any	T 24	T 12
T 23	2000 Continuous	Any	T 3	T 35	T 55	800/1000 @ 50Hz (0.01s / 0.01s) Sweeping	Any	T 24	T 12
T 24	2400 Continuous	Any	T 20	T 35	T 56	2400/2900 @ 7Hz (0.07s / 0.07s) Sweeping	Any	T 24	T 12
T 25	440 @ 0.83Hz (0.60s on, 0.60s off) Intermittent	Any	T 44	T 8	T 57	2400/2900 @ 1Hz (0.50s / 0.50s) Sweeping	Any	T 24	T 12
T 26	470 @ 0.9Hz (0.55s on, 0.55s off) Intermittent	Any	T 44	T 8	T 58	2400/2900 @ 50Hz (0.01s / 0.01s) Sweeping	Any	T 24	T 12
T 27	470 @ 5Hz (0.10s on, 0.10s off) Intermittent	Any	T 44	T 8	T 59	2500/3000 @ 2Hz (0.25s / 0.25s) Sweeping	Any	T 24	T 12
T 28	544 @ 1.14Hz (0.43s on, 0.44s off) Intermittent	Any	T 24	T 8	T 60	2500/3000 @ 7.7Hz (0.65s / 0.65s) Sweeping	Any	T 24	T 12
T 29	655 @ 0.875Hz (0.57s on, 0.57s off) Intermittent	Any	T 44	T 8	T 61	800Hz Motor Siren	Any	T 24	T 12
T 30	660 @ 0.28Hz (1.80s on, 1.80s off) Intermittent	Any	T 24	T 8	T 62	1200Hz Motor Siren	Any	T 24	T 12
T 31	660 @ 3.3Hz (0.15s on, 0.15s off) Intermittent	Any	T 24	T 8	T 63	2400Hz Motor Siren	Any	T 24	T 12
T 32	745 @ 1Hz (0.50s on, 0.50s off) Intermittent	Any	T 24	T 8	T 64	Simulated Bell	Any	T 21	T 12