

1) Warnings



- DO NOT OPEN WHEN AN EXPLOSIVE ATMOSPHERE IS PRESENT
- DO NOT OPEN WHEN ENERGISED
- POTENTIAL ELECTROSTATIC CHARGING HAZARD - CLEAN ONLY WITH A DAMP CLOTH
- DO NOT PAINT
- TO REDUCE THE RISK OF IGNITION OF HAZARDOUS ATMOSPHERES, THE FIRST CONDUIT RUN MUST HAVE A SEALING FITTING CONNECTED WITHIN 18 INCHES OF ENCLOSE. SUBSEQUENT CONDUIT RUNS MUST HAVE A SEALING FITTING CONNECTED AS CLOSE AS PRACTICAL TO THE WALL OF THE ENCLOSURE, BUT IN NO CASE MORE THAN THE SIZE OF THE CONDUIT OR 50MM, WHICHEVER IS THE LESSER.
- TO PREVENT IGNITION OF GROUP A, B, C AND D ATMOSPHERES - SEE INSTRUCTION FOR CHEMICAL COMPATIBILITY

Avertissement:

- NE PAS OUVRIR UN PRESENCE D'ATMOSPHERE EXPLOSIVE
- NE PAS OUVRIR ENERGIE
- DANGER POTENTIEL CHARGE ÉLECTROSTATIQUE - NETTOYER UNIQUEMENT AVEC UN CHIFFON HUMIDE
- NE PAS PEINTURER
- POUR RÉDUIRE LE RISQUE D'INFLAMMATION DES ATMOSPHÈRES DANGEREUSES, LE PREMIER CONDUIT DE CONDUIT DOIVENT AVOIR UN RACCORD D'ÉTANCHÉITÉ RACCORDÉ À MOINS DE 18 POUCHES DE L'ENFERMEMENT. POUR SUBSÉQUENT LES CONDUITES DE CONDUIT LA DISTANCE ENTRE LA SURFACE DE LA MASSE DE REMPLISSAGE AU PLUS PRÈS DE L'ENVELOPPE DOIT ÊTRE AUSSI PETITE QUE CE QUI EST RÉALISABLE MAIS EN AUCUN CAS SUPÉRIEURE À LA PLUS PETITE DES DIMENSIONS CORRESPONDANT À LA TAILLE DU CONDUIT OU À 50 MM.
- POUR PRÉVENIR L'INFLAMMATION DES ATMOSPHÈRES DES GROUPES A, B, C ET D-VOIR L'INSTRUCTION POUR LA COMPATIBILITÉ CHIMIQUE

2) Rating & Marking Information

2.1 NEC & CEC Class / Division Ratings for US / Canada

The D1xB2J2 Junction Box complies with the following standards:

UL 1203 (Ed. 5) 2018
CSA C22.2 No. 30-M1986 (Ed. 3) 2016
CSA C22.2 No. 25 (Ed. 4) 2017
CSA C22.2 No. 205 (Ed. 3) 2017

The D1xJ2 Junction Box is rated as follows:

Class I Div 1 Group ABCD T4A Ta -55°C to +80°C
Class I Div 1 Group ABCD T5 Ta -55°C to +75°C
Class I Div 1 Group ABCD T6 Ta -55°C to +60°C
Class II Div 1 Group EFG T4A Ta -55°C to +80°C
Class III Div 1 Ta -55°C to +80°C

Installation must be carried out in compliance with the National Electric Code / Canadian Electric Code

2.2 NEC Class / Zone ratings US

The D1xJ2 Junction Box complies with the following standards:

UL 60079-0 (Ed. 6) 2017
UL 60079-1 (Ed. 7) 2015
UL 60079-31 (Ed. 2) 2015

The D1xB2J2 Junction Box is rated as follows:

Class I Zone 1 AEx db IIC T4 Ta -55°C to +80°C
Class I Zone 1 AEx db IIC T5 Ta -55°C to +70°C
Class I Zone 1 AEx db IIC T6 Ta -55°C to +55°C
Zone 21 AEx tb IIIC T106°C Ta -55°C to +80°C

Installation must be carried out in compliance with the National Electric Code.

2.3 CEC Class / Zone ratings Canada

The D1xJ2 Junction Box complies with the following standards:

CAN/CSA C22.2 No. 60079-0 (Ed. 3) 2015
CAN/CSA C22.2 No. 60079-1 (Ed. 3) 2016
CAN/CSA C22.2 No. 60079-31 (Ed. 2) 2015

The D1xB2J2 Junction Box is rated as follows:

Ex db IIC T4 Ta -55°C to +80°C
Ex db IIC T5 Ta -55°C to +70°C
Ex db IIC T6 Ta -55°C to +55°C
Ex tb IIIC T106°C Ta -55°C to +80°C

Installation must be carried out in compliance with the Canadian Electric Code

2.4 ATEX / IECEx certification

The D1xJ2 Junction Box complies with the following standards:

EN IEC60079-0:2018 / IEC60079-0:2017 (Ed 7)
 EN60079-1:2014 / IEC60079-1 (Ed. 7) (2014)
 EN60079-31:2014 / IEC60079-31 (Ed. 2) (2013)

The D1xJ2 Junction Box is rated as follows:

Ex db IIC T4 Gb Ta -55°C to +80°C
 Ex db IIC T5 Gb Ta -55°C to +70°C
 Ex db IIC T6 Gb Ta -55°C to +55°C
 Ex tb IIIC T106°C Db Ta -55°C to +80°C

Model No.: D1xJ2

Certificate No. DEMKO 19 ATEX 2009X
 IECEX ULD 19.0006X

ATEX Mark, Equipment Group and Category:

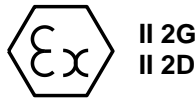

CE Marking Notified Body No.:

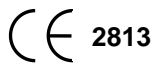

The units can be installed in locations with the following conditions:

Area Classification Gas:

Zone 1	Explosive gas air mixture likely to occur in normal operation.
Zone 2	Explosive gas air mixture not likely to occur in normal operation, and if it does, it will only exist for a short time.

Gas Groupings:

Group IIA	Propane
Group IIB	Ethylene
Group IIC	Hydrogen and Acetylene

Temperature Classification:

T1	450°C
T2	300°C
T3	200°C
T4	135°C
T5	100°C (Up to 70°C ambient)
T6	85°C (Up to 55°C ambient)

Dust Groupings:

Group IIIA	Combustible Flyings
Group IIIB	Non-conductive Dust
Group IIIC	Conductive Dust

Maximum Surface Temperature for Dust Applications:
 106°C

Equipment Category: 2G / 2D

Equipment Protection Level: Gb, Gc, Db, Dc

Ambient Temperature Range: -55°C to +80°C

The junction box must only be installed by suitably qualified personnel in accordance with the latest issues of the relevant standards:

EN60079-14 / IEC60079-14: Explosive atmospheres - Electrical installations design, selection and erection

EN60079-10-1 / IEC60079-10-1: Explosive atmospheres - Classification of areas. Explosive gas atmospheres
 EN60079-10-2 / IEC60079-10-2: Explosive atmospheres - Classification of areas. Explosive dust atmospheres
 CSA C22.1, Canadian Electrical Code, Part I, Safety Standard for Electrical Installations, Section 32
 NFPA 70, and the National Fire Alarm and signaling Code, NFPA 72

The installation of the units must also be in accordance with any local codes that may apply and should only be carried out by a competent electrical engineer who has the necessary training.

2.2 Ingress Protection Ratings

The product is rated for ingress Protection as follows:

IP rating per EN60529: IP66
 Type rating per UL50E / NEMA250: 4 / 4X / 3R / 13

Suitable for exposure to Acetone , Ammonium Hydroxide , Diethyl Ether , Ethyl Acetate , Ethylene Dichloride , Furfural , n-hexane , Methyl Ethyl Ketone , Methanol , 2-NitroPropane and Toluene.

To maintain the ingress protection rating, the cable entries must be fitted with suitably rated, certified cable entry and/or blanking devices during installation.

2.3 Electrical Ratings

Model No.	Max Current	Voltage Range	Max. Power*
D1xJ2T01	20A	60Vdc max / 260Vac 50/60Hz max.	10W
D1xJ2D01	10A		
D1xJ2M01			

The combined current load of all electrical devices powered via the Junction Box must be lower than the maximum current stated in the table above. Please refer to the specific electrical load ratings for each device powered via the junction box.

*Maximum power rating applies to allowable modules that could be mounted inside the junction box.

3) Special Conditions of Use

The enclosure coating is non-conductive and may generate an ignition-capable level of electrostatic charges under certain extreme conditions. The user should ensure that the equipment is not installed in a location where it may be subjected to external conditions (such as high pressure steam) which might cause a buildup of electrostatic charges on non-conducting surfaces. Additionally, cleaning of the equipment should be done only with a damp cloth.

Flame Path Positions

Flame Path internal thread on base shown hatched

Flame Path external thread on lid shown hatched

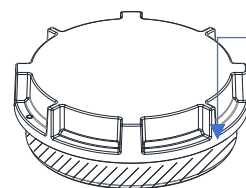
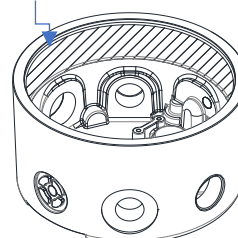

4) Installation

There are no restrictions on unit orientation.

4.1 Safe Installation Requirements

To maintain the ingress protection rating and mode of protection, the cable entries must be fitted with suitably certified cable entry and/or blanking devices during installation. If conduit is used for installation, seal conduit within 18 inches from the enclosure.

If entries are fitted with adaptors they must be suitably certified for the application. Fitting of blanking elements into adaptors is not permitted.

Check that the 'O' ring seal is in place before replacing the explosionproof cover.

5) Location and Mounting

The Junction Box should only be fixed to services that can carry the weight of the unit.

The D1xJ2X Junction box can be mounted using one of three methods.

1. The Junction Box can be surface mounted by removing, rotating and reinstalling the stowed mounting lugs. These are suitable for 6mm diameter fixings.

- a. Remove 2 x M5 fasteners per mounting lug
- b. Reverse and rotate lug and reseat onto enclosure
- c. Secure lug using the 2 x M5 Fasteners

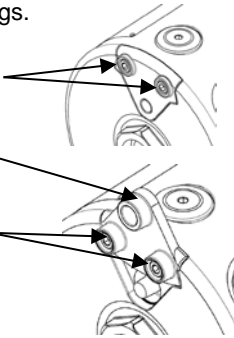

2. Alternatively the Junction Box can be conduit mounted using the 3/4" NPT entry on the base of the unit.
3. Additionally, the Junction Box can be mounted using the ratchet adjustable stainless-steel wall bracket assembly. This is available as an accessory – part code: SP77-0001.

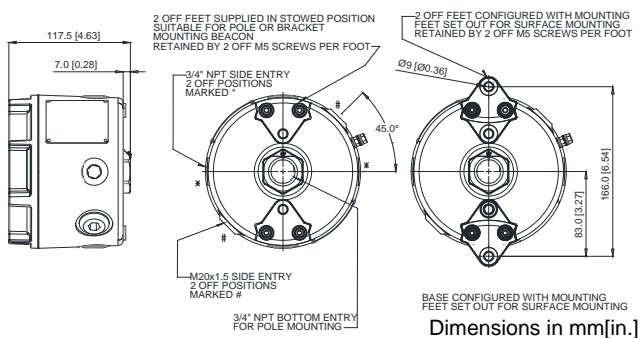

Fig. 1 Fixing Location for Junction Box

6) Access to the Enclosure



Warning – High voltage may be present, risk of electric shock. DO NOT open when energised, disconnect power before opening.



Warning – Hot surfaces. External surfaces and internal components may be hot after operation, take care when handling the equipment.

In order to connect the electrical supply cables to the junction box, it is necessary to open the explosion proof enclosure. Loosen the locking grub screw in the junction box cover and then remove the lid to gain access to the chamber. This can be achieved by unscrewing the cover, taking extreme care not to damage the threads when doing so.

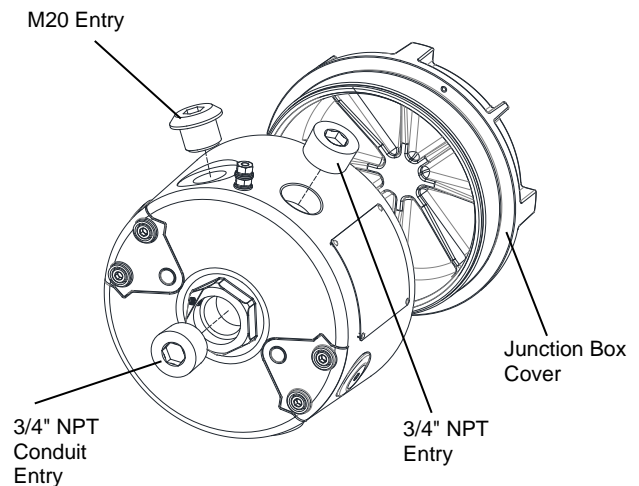

Fig. 2 Accessing the Enclosure.

On completion of the installation the flameproof threads should be inspected to ensure that they are clean and that they have not been damaged during installation. Ensure the O-ring seal is in place and undamaged.

When fitting the flameproof cover ensure the thread is engaged correctly. Fully tighten the cover all the way, ensure no gap is visible between the cover and base of the enclosure.

7) Selection of Cable, Cable Glands, Blanking Elements & Adapters

When selecting the cable size, consideration must be given to the input current that each unit is carrying (see section 2.3). The cable size selected must have the necessary capacity to provide the input current to all of the units connected to the line.

The entries are 2-off M20 x 1.5 thread & 5-off 3/4" NPT thread

If a high IP (Ingress Protection) rating is required then a suitable sealing washer must be fitted under the cable glands or blanking plugs.

For use in explosive dust atmospheres, a minimum ingress protection rating of IP6X must be maintained.

For use in explosive gas atmospheres, a minimum ingress protection rating of IP54 must be maintained.

NPT plugs should be greased before insertion.

For high ambient temperatures the cable entry temperature or the cable branching point temperature may exceed 60°C and therefore suitable heat resisting cables and cable glands must be used, with a rated service temperature of at least the values stated below:

Max Ambient temperature (°C)	45	50	55	60	65	70	75	80
Req. cable gland rating (°C)	65	70	75	80	85	90	95	100

8) Cable Connections

The units have 2-off M20 x 1.5 threaded entries and 5-off 3/4" NPT x 14 threaded entries.

Electrical connections are to be made into the terminal blocks or DIN-rail mounted inside the junction box enclosure. See section 5 of this manual for access to the enclosure.

Wires having a cross sectional area between 0.5 mm² to 2.5mm² can be connected to each terminal way. If fitting 2-off wires to one terminal way the sum of the 2-off wires must be a maximum cross sectional area of 2.5mm². For Terminals strip wires to 5mm, for DIN rails strip to 8mm. Wires may also be fitted using ferrules. Terminal screws need to be tightened down with a tightening torque of 0.4Nm / 3.5lb-in and DIN rails screws to 0.56 Nm / 5 Lb-in. When connecting wires to any terminals great care should be taken to dress the wires so that when the cover is inserted into the chamber the wires do not exert excess pressure on the terminal blocks. This is particularly important when using cables with large cross sectional areas such as 2.5mm².

9) Variants

The D1xJ2 Junction boxes are available pre-fitted with 12-way terminal (Fig. 3a) or DIN Rail (Fig. 3b) connections. A D1xJ2M01 custom module variant is also available, please refer to the website for further info.

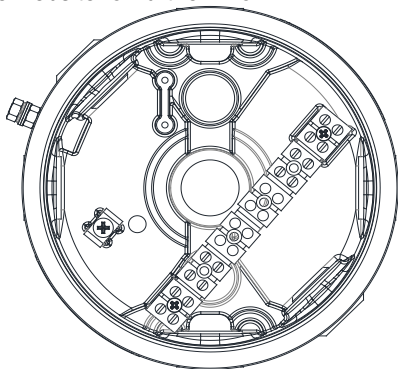

Fig. 3a – D2xJ2T01 12-way terminal block variant.

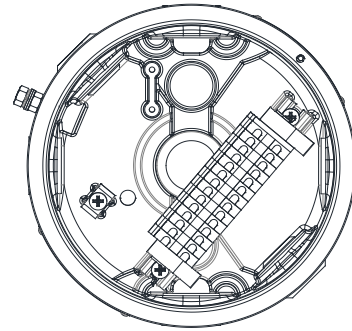

Fig. 3b – D2xJ2D01 12-way DIN Rail variant.

10) Earthing

The unit has an external and an internal earth terminal, (please see fig 4).

Internal earthing connections should be made to the internal Earth terminal in the base of the housing using a ring crimped terminal to secure the earth conductor under the earth clamp. The earth conductor should be at least equal in size and rating to the incoming power conductors.

External earthing connections should be made to the M5 earth stud, using a ring crimp terminal to secure the earth conductor to the earth stud. The external earth conductor should be at least 4mm² in size.

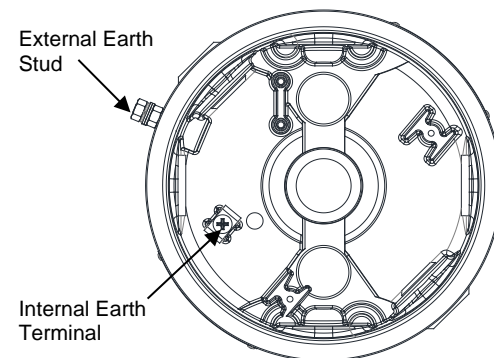
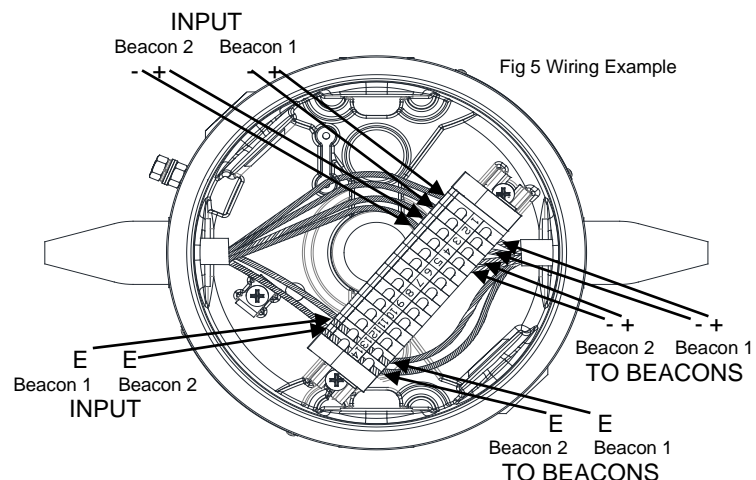

Fig. 4: Internal & External Earth Locations

11) Typical Example of 2-way Beacon Wiring through Junction Box



Note: D1xJ2D01 shown. DIN Rail Earth terminals are colour coded Green/Yellow.

12) Maintenance, Overhaul & Repair

Maintenance, repair and overhaul of the equipment should only be carried out by suitably qualified personnel in accordance with the current relevant standards:

EN60079-19 / IEC60079-19 Explosive atmospheres -
Equipment repair, overhaul and reclamation
EN 60079-17 / IEC60079-17 Explosive atmospheres -
Electrical installations inspection and maintenance

To avoid a possible ELECTROSTATIC CHARGE the unit must only be cleaned with a damp cloth.

Units must not be opened while an explosive atmosphere is present.

If opening the unit during maintenance operations a clean environment must be maintained and any dust layer removed

Flameproof joints are not intended to be repaired.