

INSTRUCTION MANUAL

D2xB1X05 & D2xB1X10 Xenon Beacons

For use in Hazardous Locations

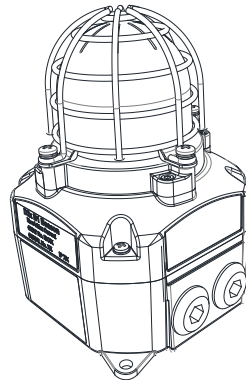

D2XB1X05
D2XB1X10

1) Product Table

Model	Nom. Voltage	Voltage Range	Operating rms Current
D2xB1X05DC024	24Vdc	20-28Vdc	296mA
D2xB1X05DC048	48Vdc	48Vdc	145mA
D2xB1X05AC115	115Vac	115-120Vac 50/60Hz	80mA
D2xB1X05AC230	230Vac	220-230Vac 50/60Hz	30mA
D2xB1X10DC024	24Vdc	20-28Vdc	609mA
D2xB1X10DC048	48Vdc	48Vdc	260mA
D2xB1X10AC115	115Vac	115-120Vac 50/60Hz	185mA
D2xB1X10AC230	230Vac	220-230Vac 50/60Hz	107mA

Table 1: Electrical Ratings.

2) Warnings



- DO NOT OPEN WHEN AN EXPLOSIVE ATMOSPHERE IS PRESENT
- DO NOT OPEN WHEN ENERGISED
- POTENTIAL ELECTROSTATIC CHARGING HAZARD - CLEAN ONLY WITH A DAMP CLOTH
- HIGH VOLTAGE SHOCK HAZARD. WAIT 5 MINUTES AFTER REMOVING POWER BEFORE OPENING THE ENCLOSURE

Avertissement:

- NE PAS OUVRIR UN PRESENCE D'ATMOSPHERE EXPLOSIVE
- NE PAS OUVRIR ENERGIE
- DANGER POTENTIEL CHARGE ÉLECTROSTATIQUE - NETTOYER UNIQUEMENT AVEC UN CHIFFON HUMIDE
- HAUT TENSION, RISK DE CHOC. ATTENDEZ 5 MINUTES APRES AVOIR DEBRANCHE L'ALIMENTATION AVANT D'OUVRIR LA BOITIER

3) Rating & Marking Information

All units have a rating label, which carries the following important information:

- Unit Model.
- Voltage Range
- Nominal Voltage

See Table 1 for electrical ratings of each Unit Model.

3.1. Fire Alarm Ratings

The Following models are certified as visual alarm devices for private mode visual alarm devices in accordance with UL1638 Fifth Edition / CAN/ULC-S526 Fourth Edition when used with clear or red lens covers:

D2XB1X05DC024 ; D2XB1X05DC048
D2XB1X10DC024 ; D2XB1X10DC048

See fire instruction manual D211-00-201-IS-SC-UL

3.2. ATEX / IECEx / UKEx Ratings

Standards	
EN IEC 60079-0:2018 / IEC60079-0:2017 (Ed 7): Explosive Atmospheres - Equipment. General Requirements EN IEC 60079-7:2015 +A1:2018 / IEC 60079-7:2018 (Ed. 5.1): Explosive Atmospheres - Equipment Protection by Increased Safety "e" EN 60079-31:2014 / IEC 60079-31:2013 (Ed 2): Explosive Atmospheres - Equipment Dust Ignition Protection by Enclosure "t"	
Ratings	
D2xB1: X05DC024	Ex ec IIC T2 Gc Ta -40°C to +50°C Ex tc IIIC T80°C Dc Ta -40°C to +50°C
D2xB1: X05DC048 X05AC115 X05AC230	Ex ec IIC T3 Gc Ta -40°C to +50°C Ex tc IIIC T95°C Dc Ta -40°C to +50°C
D2xB1: X10DC024	Ex ec IIC T1 Gc Ta -40°C to +50°C Ex tc IIIC T105°C Dc Ta -40°C to +50°C
D2xB1: X10DC048 X10AC115 X10AC230	Ex ec IIC T2 Gc Ta -40°C to +50°C Ex tc IIIC T95°C Dc Ta -40°C to +50°C

Certificate No. DEMKO 14 ATEX 4786493904X
IECEx ULD 14.0004X
UL21UKEX2131X

ATEX Mark, Equipment Group and Category:

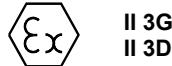

CE Marking



UKCA Marking



3.3. NEC & CEC Ratings

NEC & CEC Class / Division Ratings for US / Canada

Standards	
UL 121201-2021 (Ed. 9) CAN/CSA C22.2 No. 213-17 (Ed. 3)	
Ratings	
D2xB1: X05DC024	Class I Div 2 ABCD T2D Ta -40°C to +50°C Class I Div 2 ABCD T3 Ta -40°C to +45°C Class II Div 2 FG T6 Ta -40°C to +50°C Class III Div 1&2 Ta -40°C to +50°C
D2xB1: X05DC048 X05AC115 X05AC230	Class I Div 2 ABCD T3 Ta -40°C to +50°C Class II Div 2 FG T5 Ta -40°C to +50°C Class II Div 2 FG T6 Ta -40°C to +40°C Class III Div 1&2 Ta -40°C to +50°C
D2xB1: X10DC024	Class I Div 2 ABCD T1 Ta -40°C to +50°C Class I Div 2 ABCD T2 Ta -40°C to +45°C Class II Div 2 FG T4A Ta -40°C to +50°C Class II Div 2 FG T5 Ta -40°C to +45°C Class III Div 1&2 Ta -40°C to +50°C

D2xB1: X10DC048 X10AC115 X10AC230	Class I Div 2 ABCD T2B Ta -40°C to +50°C Class II Div 2 FG T5 Ta -40°C to +50°C Class II Div 2 FG T6 Ta -40°C to +40°C Class III Div 1&2 Ta -40°C to +50°C
Installation must be carried out in compliance with the National Electric Code / Canadian Electric Code	

NEC Class / Zone ratings US

Standards	
UL 60079-0 (Ed. 7): Explosive Atmospheres - part 0: Equipment - General Requirements UL 60079-7 (Ed. 5): Explosive Atmospheres - Equipment Protection by Increased Safety "e" UL 60079-31 (Ed. 2) Explosive Atmospheres - Equipment Dust Ignition Protection by Enclosure "t"	
Ratings	
D2xB1: X05DC024	Class I Zone 2 AEx ec IIC T2 Gc Ta -40°C to +50°C Zone 22 AEx tc IIIC T80°C Dc Ta -40°C to +50°C
D2xB1: X05DC048 X05AC115 X05AC230	Class I Zone 2 AEx ec IIC T3 Gc Ta -40°C to +50°C Zone 22 AEx tc IIIC T95°C Dc Ta -40°C to +50°C
D2xB1: X10DC024	Class I Zone 2 AEx ec IIC T1 Gc Ta -40°C to +50°C Zone 22 AEx tc IIIC T105°C Dc Ta -40°C to +50°C
D2xB1: X10DC048 X10AC115 X10AC230	Class I Zone 2 AEx ec IIC T2 Gc Ta -40°C to +50°C Zone 22 AEx tc IIIC T95°C Dc Ta -40°C to +50°C
Installation must be carried out in compliance with the National Electric Code.	

CEC Class / Zone ratings Canada

Standards	
CAN/CSA C22.2 No. 60079-0 (Ed. 4) 02/2019 Explosive Atmospheres - Part 0: Equipment - General Requirements CAN/CSA C22.2 No. 60079-7 (Ed. 2) Explosive Atmospheres - Equipment Protection by Increased Safety "e" CAN/CSA C22.2 No. 60079-31 (Ed. 2) Explosive Atmospheres - Equipment Dust Ignition Protection by Enclosure "t"	
Rating	
D2xB1: X05DC024	Ex ec IIC T2 Gc X Ta -40°C to +50°C Ex tc IIIC T80°C Dc Ta -40°C to +50°C
D2xB1: X10DC024	Ex ec IIC T1 Gc X Ta -40°C to +50°C Ex tc IIIC T105°C Dc Ta -40°C to +50°C
D2xB1: X05DC048 X05AC115 X05AC230	Ex ec IIC T3 Gc X Ta -40°C to +50°C Ex tc IIIC T95°C Dc X Ta -40°C to +50°C

D2xB1: X10DC048 X10AC115 X10AC230	Ex ec IIC T2 Gc X Ta -40°C to +50°C Ex tc IIIC T95°C Dc Ta -40°C to +50°C
Installation must be carried out in compliance with the Canadian Electric Code	

IP6X to EN/IEC60079-0 IP66 to EN60529 To maintain the ingress protection rating, the two off cable entries must be fitted with suitably rated, certified cable entry and/or blanking devices during installation.
Type Rating
Per UL50E / NEMA250: 4 / 4X / 3R / 13

4) Zones, Gas Group, Category and Temperature Classification

When connected to an approved system the D2X beacon may be installed in:

Area Classification	
Zone 2	Explosive gas air mixture not likely to occur in normal operation, and if it does, it will only exist for a short time.
Zone 22	Explosive dust air mixture not likely to occur in normal operation, and if it does, it will only exist for a short time.
Gas Groupings	
Group IIA	Propane
Group IIB	Ethylene
Group IIC	Hydrogen and Acetylene
Temperature Classification for Gas Applications	
T1	450°C
T2	300°C (Excluding D2xB1X10DC024)
T3	200°C (D2xB1X05DC048 & D2xB1X05AC only)
Dust Groupings (ATEX / IECEx / UKEX only)	
Group IIIA	Combustible Flyings
Group IIIB	Non-conductive Dust
Group IIIC	Conductive Dust
Maximum Surface Temperature for Dust Applications (ATEX / IECEx / UKEX only)	
D2xB1: X05DC024	80°C
All 48VDC, 115VAC & 230VAC units	95°C
D2xB1: X10DC024	105°C
Equipment Category	
3G / 3D	
Equipment Level Protection	
Gc, Dc	
Ambient Temperature Range	
-40°C to +70°C	
IP Rating	

5) Special Conditions of Use

Special Condition for safe Use as stated on the Type Examination Certificate DEMKO 14 ATEX 4786493904X / CoC IECEx ULD 14.0004X / UL21UKEX2131X:

When used for a Group III application, the surface of the enclosure may store electrostatic charge and become a source of ignition in applications with a low relative humidity <~30% relative humidity where the surface is relatively free of surface contamination such as dirt, dust, or oil.

Guidance on protection against the risk of ignition due to electrostatic discharge can be found in EN TR50404 and IEC TR60079-32.

End user shall adhere to the manufacturer's installation and instruction when performing housekeeping to avoid the potential for hazardous electrostatic charges during cleaning, by using a damp cloth.

To maintain the ingress protection rating and mode of protection, the cable entries must be fitted with suitably rated, certified cable entry and/or blanking devices during installation.

6) Product Mounting and Access

6.1. Location and Mounting

The location of the beacon should be made with due regard to the area over which the warning signal must be visible. It should only be fixed to services that can carry the weight of the unit.

The D2x beacon should be secured to any flat surface using the two 7mm fixing holes in the feet of the base. The 2-off feet must first be fitted to the base using the 2-off M4 X 12mm countersunk screws provided. The unit can also be pole mounted using the 3/4" NPT Entry in the centre of the base. See Fig. 1.

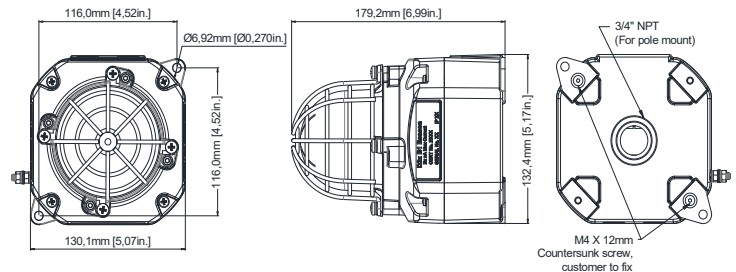

Fig. 1 Fixing Location for Beacon

6.2. Access to the Enclosure



Warning – High voltage may be present, risk of electric shock. DO NOT open when energised, disconnect power before opening.

Warning – Hot surfaces. External surfaces and internal components may be hot after operation, take care when handling the equipment.

To access the enclosure, loosen the four M4 posi pan head screws and withdraw the cover.

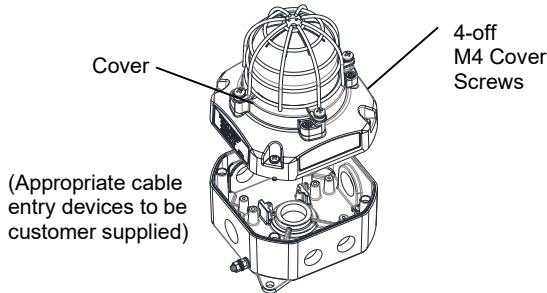

Fig. 2 Accessing the Enclosure.

To replace cover, check that the 'O' ring seal is in place. Carefully push the cover in place. Insert M4 screws with fiber washers and tighten to 3Nm torque.

7) Selection of Cable. Cable Glands, Blanking Elements & Adapters

When selecting the cable size, consideration must be given to the input current that each unit draws (see Table 1), the number of sounders on the line and the length of the cable runs. The cable size selected must have the necessary capacity to provide the input current to all of the sounders connected to the line.

The entries can be ordered with one of the following options:

2-off M20 x 1.5 thread, 2-off 1/2" NPT thread & 1-off 3/4" NPT thread

If a high IP (Ingress Protection) rating is required then a suitable sealing washer must be fitted under the cable glands or blanking plugs.

For use in explosive dust atmospheres, a minimum ingress protection rating of IP6X must be maintained.

For use in explosive gas atmospheres, a minimum ingress protection rating of IP54 must be maintained.

NPT plugs should be greased before insertion.

8) Cable Connections

Electrical connections are to be made into the terminal blocks on the PCBA located in the enclosure. See section 6 of this manual for access to the enclosure.

Wires having a cross sectional area between 0.5 mm² to 2.5mm² can be connected to each terminal way. If an input and output wire is required the 2-off Live/Neutral or +/- terminals can be used. If fitting 2-off wires to one terminal way the sum of the 2-off wires must be a maximum cross

sectional area of 2.5mm². Strip wires to 8mm. Wires may also be fitted using ferrules. Terminal screws need to be tightened down with a tightening torque of 0.56 Nm / 5 Lb-in. When connecting wires to the terminals great care should be taken to dress the wires so that when the cover is inserted into the chamber the wires do not exert excess pressure on the terminal blocks. This is particularly important when using cables with large cross sectional areas such as 2.5mm².

9) Wiring

For further wiring schematics refer to document D211-06-201

9.1. AC Wiring

3-off 2-way terminal blocks are provided on the AC beacon for power. There are 2-off Live, 2-off Neutral and 2-off Earth terminals in total.

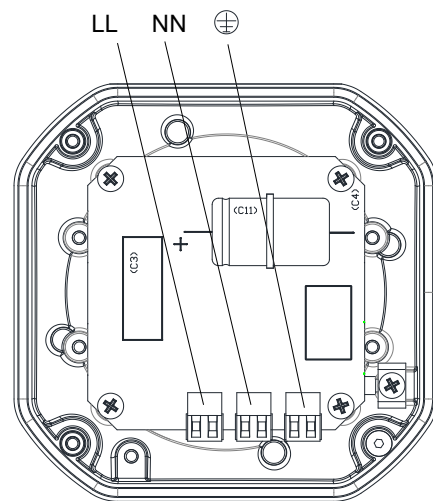

Fig. 4 D2xB1X05/D2xB1X10 AC Terminals

9.2. DC Wiring

3-off 2-way terminal blocks are provided on the AC beacon for power. There are 2-off +ve, 2-off -ve and 2-off Earth terminals in total.

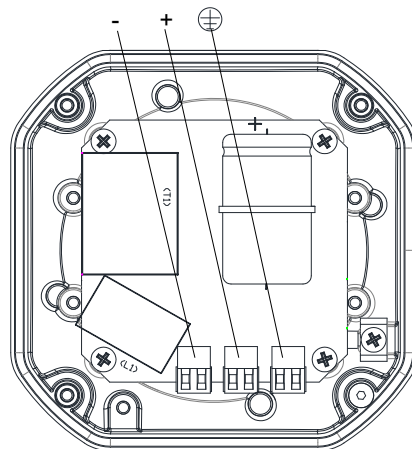

Fig. 6a D2xB1X05/D2xB1X10 48 VDC Terminals

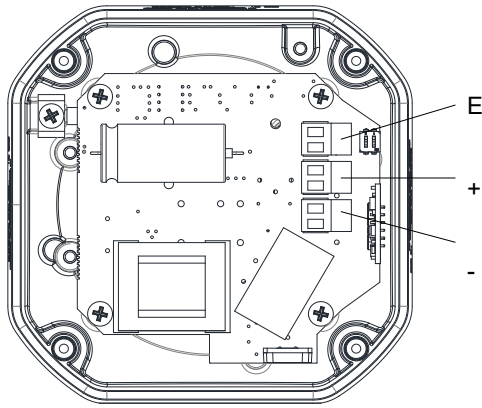

Fig. 6b D2xB1X05/D2xB1X10 24 VDC Terminals

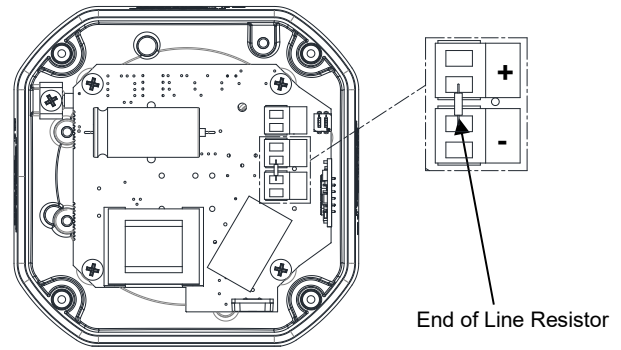

Fig. 8b End of Line Resistor Placement (D2xB1DC024)

10) Line Monitoring (DC Units only)

On D2xB1X05/D2xB1X10 DC units, DC reverse line monitoring can be used if required. All DC beacons have a blocking diode fitted in their supply input lines. An end of line monitoring resistor can be connected across the +ve and -ve terminals. If an end of line resistor is used it must have the following values:

	Min. Resistance	Min. Power
24V DC	3.9KΩ	0.5W
	1KΩ	2W
48V DC	15KΩ	0.5W
	3.9KΩ	2W

The resistor must be connected directly across the +ve and -ve terminals as shown in the following drawing. Form the resistor legs as shown in Fig. 8a, remove the +ve and -ve terminal plugs and fit the resistor across the two terminal plugs before refitting them to the PCBA as shown in Fig. 8a or 8b. A spacing of at least 1/16" (1.58mm) must be provided through air and over surfaces between uninsulated live parts.

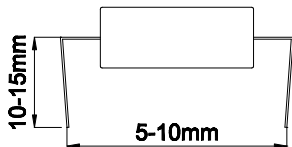

Fig. 7 End of Line Resistor Forming

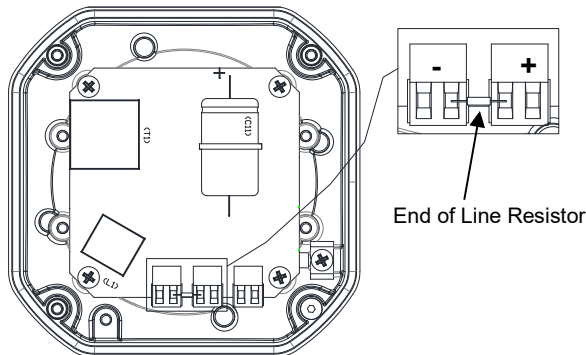

Fig. 8a End of Line Resistor Placement (D2xB1DC048)

11) Interchangeable & Spare Parts



Warning – Hot surfaces. External surfaces and internal components may be hot after operation, take care when handling the equipment.

The Beacon lens cover is interchangeable, contact E2S Ltd for a replacement lens cover available in various colours.

To change the lens cover, unscrew the 4-off M5 posi pan head screws, spring and flat washers using a screwdriver. Remove the wire guard and replace the old lens cover with the new lens cover.

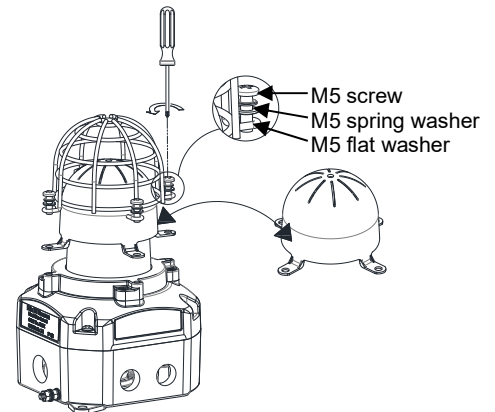

Fig. 9 Replacement of beacon lens cover

Fit the wire guard back onto the housing, over the new lens cover aligning the fixing holes of the guard, lens cover and housing. Refit the fixings to hold into place, the fixings MUST be fitted in the order shown above.

12) DIP Switch

Please note that the D2xB1X05DC024 & D2xB1X10DC024 beacon PCBAs have a DIP Switch that is NOT customer configurable. This should only ever be set to '00'.

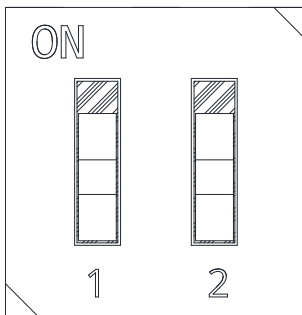

Fig. 7 DIP Switch setting '00'

13) Maintenance, Overhaul & Repair

Maintenance, repair and overhaul of the equipment should only be carried out by suitably qualified personnel in accordance with the current relevant standards:

- EN60079-19 Explosive atmospheres - Equipment repair, overhaul and reclamation
- IEC60079-19
- EN 60079-17 Explosive atmospheres - Electrical installations inspection and maintenance
- IEC60079-17

To avoid a possible ELECTROSTATIC CHARGE the unit must only be cleaned with a damp cloth.

Units must not be opened while an explosive atmosphere is present.

If opening the unit during maintenance operations a clean environment must be maintained and any dust layer removed prior to opening the unit.

FIRE INSTRUCTION MANUAL

D2xB1X05 & D2xB1X10 Xenon Beacons

For use in Hazardous Locations



1) Warnings

- DO NOT PAINT



Avertissement:

- NE PAS PEINTURER

2) Rating & Marking Information

2.1 Fire Alarm Ratings

The Following models are certified as visual alarm devices for private mode visual alarm devices in accordance with UL1638 Fifth Edition / CAN/ULC-S526 Fourth Edition when used with clear or red lens covers:

D2xB1X05DC024 / D2xB1X05DC048
D2xB1X10DC024 / D2xB1X10DC048

On-axis light output per UL1638 at 1Hz:

Model	Lens cover colour	Light output in cd
D2xB1X05DC024	clear	17.4
	red	5.4
D2xB1X05DC048	clear	30
	red	12
D2xB1X10DC024	clear	53.4
	red	17.4
D2xB1X10DC048	clear	82
	red	26

2.2 surge current ratings for use in fire alarm systems

Model	Peak Surge current	RMS surge current
D2xB1X05DC024	1.04A	437mA
D2xB1X05DC048	12.7A	1.45A
D2xB1X10DC024	0.99A	620mA
D2xB1X10DC048	14.5A	780mA

1	2	3	4	5	6	7	8	9	10
							ISSUE	MOD No.	REASON - INITIAL - DATE
							1		INTRODUCTION RSR 02-01-2020
							2		UPDATED FORMAT DH 17-05-2022

DC XENON D2XB1X05 / X10 UNITS
Line Monitoring
Power: +ve & -ve

AC D2XB1X05 / X10 UNITS
Power: Live & Neutral

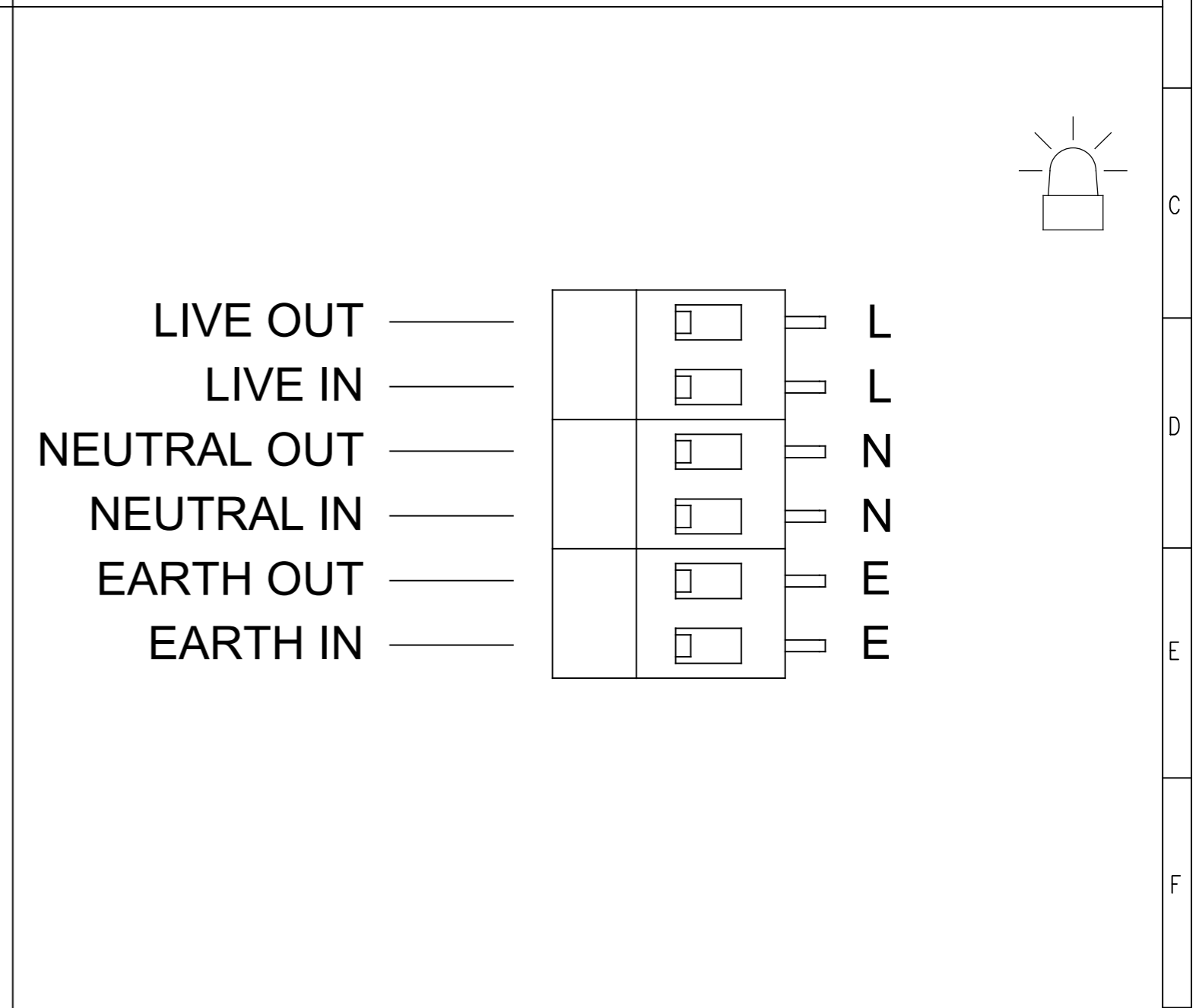
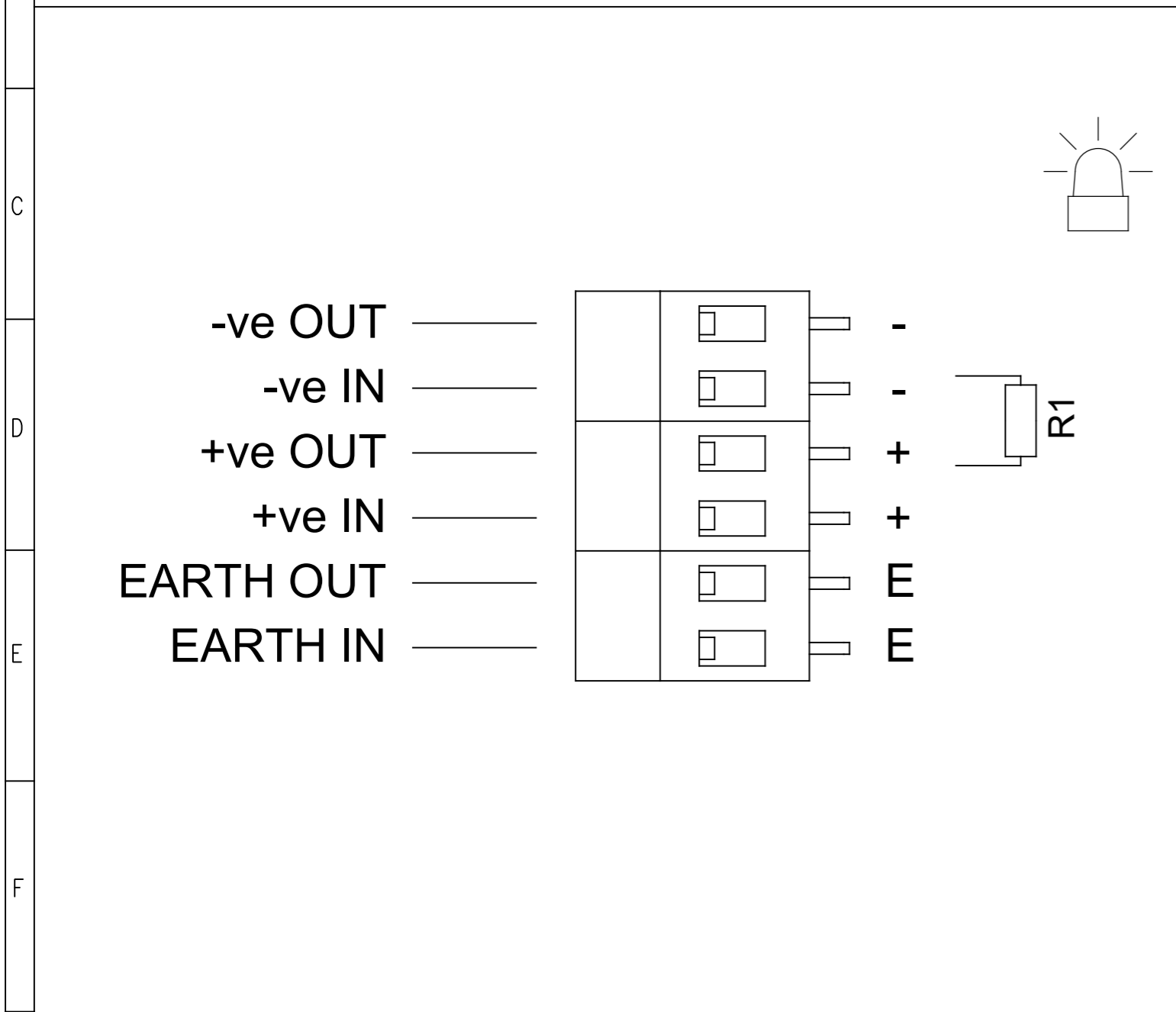

DRAWING TO BS8888:2000 GEOMETRIC TOLERANCES TO ISO1101:1983 LINEAR DIMENSIONAL TOLS +/-0.35mm ANGULAR DIMENSIONAL TOLS +/-2 deg STANDARDS D2x	DRAWN R.S. RAIT	DATE 27-06-2019	SURFACE FINISH	WEIGHT (Kg)	THIS DRAWING AND ANY INFORMATION OR DESCRIPTIVE MATTER THEREIN IS COMMUNICATED IN CONFIDENCE AND IS THE COPYRIGHT PROPERTY OF EUROPEAN SAFETY SYSTEMS LTD. NEITHER THE WHOLE OR ANY EXTRACT MAY BE DISCLOSED, LOANED, COPIED OR USED FOR MANUFACTURING OR TENDERING PURPOSES WITHOUT THEIR WRITTEN CONSENT. © EUROPEAN SAFETY SYSTEMS LTD. AS PER LATEST DATE OF ISSUE SHOWN ABOVE	 EUROPEAN SAFETY SYSTEMS LTD IMPRESS HOUSE MANSELL ROAD ACTON LONDON W3 7QH WWW.E2S.COM	ALL DIMENSIONS IN MM IF IN DOUBT, ASK - DO NOT SCALE	 A3
	CHECKED B. ISARD	DATE 27-06-2019	MATERIAL				TITLE D2xB1X05 & D2xB1X10 WIRING DIAGRAM	
	APPROVED R.N.POTTS	DATE 27-06-2019	ALTERNATIVE MATERIAL				SCALE NTS	SHEET 1 OF 1

EU Declaration of Conformity



Manufacturer: European Safety Systems Ltd.
Impress House, Mansell Road, Acton
London, W3 7QH
United Kingdom

Authorised Representative: E2S Warnsignaltechnik UG
Charlottenstrasse 45-51
72764 Reutlingen
Germany

Equipment Type: D2xS1, D2xC1X05, D2xC1X10
D2xB1X05, D2xB1X10, D2xB1LD2, D2xB1XH1, D2xB1XH2, D2xB1LD3
D2xC2X05, D2xC2X10, D2xC2LD2, D2xC2XH1, D2xC2XH2, D2xC2LD3
D2xJ1

Directive 2014/34/EU: Equipment and Protective Systems for use in Potentially Explosive Atmospheres (ATEX)

Notified Body for EU type Examination (Module B):	UL International Demko A/S Notified Body No.: 0539 Borupvang 5A, 2750 Ballerup, Denmark
EU-type Examination Certificate (Module B):	DEMKO 14 ATEX 4786493904X
Notified Body for Quality Assurance Notification / Conformity to EU-type based on quality assurance of the production process (Module D):	Sira Certification Service Notified Body No.: 2813 CSA Group Netherlands B.V, Utrechtseweg 310, 6812 AR, Arnhem, Netherlands
Quality Assurance Notification (Module D):	SIRA 05 ATEX M342
Provisions fulfilled by the equipment:	II 3G Ex ec IIC T6/T4/T3/T2/T1 Gc II 3D Ex tc IIIC Ex tc IIIC T5/75/80/85/90/95/105/110°C Dc IP66 Ingress / Dust Protection to EN60079-0 / EN60079-31
Standards applied:	EN IEC 60079-0:2018 EN IEC 60079-7:2015 +A1:2018 EN 60079-31:2014

Directive 2014/30/EU: Electromagnetic Compatibility Directive (EMC)

Standards applied:	EN 61000-6-1:2007 EN 61000-6-2:2005 EN 61000-6-3:2007 / A1:2011 / AC: 2012 EN 61000-6-4:2007 / A1: 2011
--------------------	--

Directive 2011/65/EU: Restriction of the use of certain hazardous substances in electrical and electronic equipment (RoHS)

The product and all the components contained within it are in accordance with the restriction of the use of hazardous substances in electrical and electronic equipment, including amendment by Directive 2015/863/EU.

Regulation (EC) 1907/2006: Registration, Evaluation, Authorisation and Restriction of Chemicals (REACH)

The product and all the components contained within it are free from substances of very high concern.

Other Standards and Regulations

EN 60529:1992+A2:2013 - Degrees of protection provided by enclosures (IP code) – enclosure rated IP66

EU Declaration of Conformity



On behalf of European Safety Systems Ltd., I declare that, on the date the equipment accompanied by this declaration is placed on the market, the equipment conforms with all technical and regulatory requirements of the above listed directives, regulations and standards.

This Declaration is issued under the sole responsibility of the manufacturer.

A handwritten signature in black ink, appearing to read 'Martin Streetz'.

Martin Streetz
Quality Assurance Manager

Document No.: DC-061_Issue_J
Date and Place of Issue: London, 22/08/2022



UKCA Declaration of Conformity



Manufacturer: European Safety Systems Ltd.
Impress House, Mansell Road, Acton
London, W3 7QH
United Kingdom

Equipment Type: D2xS1, D2xC1X05, D2xC1X10
D2xB1X05, D2xB1X10, D2xB1LD2, D2xB1XH1, D2xB1XH2, D2xB1LD3
D2xC2X05, D2xC2X10, D2xC2LD2, D2xC2XH1, D2xC2XH2, D2xC2LD3
D2xJ1

Directive UKSI 2016:1107 (as amended by UKSI 2019:696) – Schedule 3A, Part 1 : Product or Protective System Intended for use in Potentially Explosive Atmospheres (UKCA)

Notified Body for UK type Examination (Module B):	UL International (UK) Ltd Notified Body No.: 0843 Unit 1-3 Horizon Kingsland Business Park, Wade Road, Basingstoke, Hampshire RG24 8AH UK
UK-type Examination Certificate (Module B):	UL21UKEX2131X
Notified Body for Quality Assurance Notification / Conformity to EU-type based on quality assurance of the production process (Module D):	Sira Certification Service Notified Body No.: 0518 Rake Lane, Eccleston, Chester CH4 9JN, UK
Quality Assurance Notification (Module D):	CSAE 22UKQAN0046
Provisions fulfilled by the equipment:	II 3G Ex ec IIC T6/T4/T3/T2/T1 Gc II 3D Ex tc IIIC Ex tc IIIC T5/75/80/85/90/95/105/110°C Dc IP66 Ingress / Dust Protection to EN60079-0 / EN60079-31
Standards applied:	EN IEC 60079-0:2018 EN IEC 60079-7:2015 +A1:2018 EN 60079-31:2014

Directive 2014/30/EU: Electromagnetic Compatibility Directive (EMC)

Standards applied:	EN 61000-6-1:2007 EN 61000-6-2:2005 EN 61000-6-3:2007 / A1:2011 / AC: 2012 EN 61000-6-4:2007 / A1: 2011
--------------------	--

Directive 2011/65/EU: Restriction of the use of certain hazardous substances in electrical and electronic equipment (RoHS)

The product and all the components contained within it are in accordance with the restriction of the use of hazardous substances in electrical and electronic equipment, including amendment by Directive 2015/863/EU.

Regulation (EC) 1907/2006: Registration, Evaluation, Authorisation and Restriction of Chemicals (REACH)

The product and all the components contained within it are free from substances of very high concern.

Other Standards and Regulations

EN 60529:1992+A2:2013 - Degrees of protection provided by enclosures (IP code) – enclosure rated IP66



UKCA Declaration of Conformity



On behalf of European Safety Systems Ltd., I declare that, on the date the equipment accompanied by this declaration is placed on the market, the equipment conforms with all technical and regulatory requirements of the above listed directives, regulations and standards.

This Declaration is issued under the sole responsibility of the manufacturer.

Martin Streetz
Quality Assurance Manager

Document No.:
Date and Place of Issue:

DC-102_Issue_A
London, 22/08/2022