

INSTRUCTION MANUAL

D2xC2LD3 Alarm Horn and LED

For use in Hazardous Locations

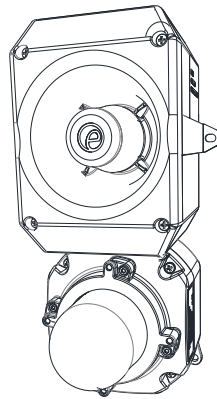

D2XC2LD3

1) Product Table

Model	Nominal Voltage	Nominal Beacon Current	Nominal Sounder Current
D2xC2LD3DC024	20-28Vdc	248mA	250mA
For detailed max current ratings of the device please see Section 14.			
Table 1: Electrical Ratings			

2) Warnings



- DO NOT OPEN WHEN AN EXPLOSIVE ATMOSPHERE IS PRESENT
- DO NOT OPEN WHEN ENERGISED
- POTENTIAL ELECTROSTATIC CHARGING HAZARD - CLEAN ONLY WITH A DAMP CLOTH

Avertissement:

- NE PAS OUVRIR UN PRESENCE D'ATMOSPHERE EXPLOSIVE
- NE PAS OUVRIR ENERGIE
- DANGER POTENTIEL CHARGE ÉLECTROSTATIQUE - NETTOYER UNIQUEMENT AVEC UN CHIFFON HUMIDE

3.1. ATEX / IECEx / UKEx certification

Standards	
EN IEC 60079-0:2018 / IEC60079-0:2017 (Ed 7): Explosive Atmospheres - Equipment. General Requirements	
EN IEC 60079-7:2015 +A1:2018 / IEC 60079-7:2018 (Ed. 5.1): Explosive Atmospheres - Equipment Protection by Increased Safety "e"	
EN 60079-31:2014 / IEC 60079-31:2013 (Ed 2): Explosive Atmospheres - Equipment Dust Ignition Protection by Enclosure "t"	
Ratings	
D2xC2LD3:	Ex ec IIC T4 Gc Ta -40°C to +50°C Ex tc IIIC T75°C Dc Ta -40°C to +50°C

3) Rating & Marking Information

3.1. Fire Alarm Ratings

The D2xC2LD3DC024 is certified for use as a public mode audible and visual alarm device in accordance with UL464 Tenth Edition / CAN/ULC-S525 Fourth Edition and UL1638 Fifth Edition / CAN/ULC-S526 Fourth Edition.

The D2xC2LD3DC024 is approved for use as an Audible and Visual Appliance for use in Private Mode Fire Alarm System in accordance with UL464 Tenth Edition / CAN/ULC-S525 Fourth Edition and UL1638 Fifth Edition / CAN/ULC-S526 Fourth Edition.

See fire instructions D211-00-671-IS-SC-UL

Certificate No. DEMKO 14 ATEX 4786493904X
IECEX ULD 14.0004X
UL21UKEX2131X

ATEX Mark, Equipment Group and Category:

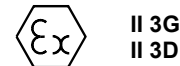

II 3G
II 3D

CE Marking



UKCA Marking



3.2. NEC & CEC Ratings

NEC & CEC Class / Division Ratings for US / Canada

Standards	
UL1971 Ed. 3 2018 UL1638 Ed. 5 2017 / CAN/ULC-S526 Ed. 4 UL464 Ed. 10 2017 / CAN/ULC-S525 Ed. 4 CSA C22.2 No. 205-17 UL 121201-2021 Edition 9 CAN/CSA C22.2 No. 213-17 Edition 3	
Ratings	
D2xC2LD3:	Class I Div 2 ABCD T4 Ta -40°C to +50°C Class II Div 2 FG T6 Ta -40°C to +50°C Class III Div 1&2 Ta -40°C to +50°C
The certification approval has validated continuous use up to 38°C and are for transient use up to 50°C ambient.	
Installation must be carried out in compliance with the National Electric Code / Canadian Electric Code	

NEC Class / Zone ratings US

Standards	
UL 60079-0 (Ed. 7): Explosive Atmospheres - part 0: Equipment - General Requirements UL 60079-7 (Ed. 5): Explosive Atmospheres - Equipment Protection by Increased Safety "e" UL 60079-31 (Ed. 2) Explosive Atmospheres - Equipment Dust Ignition Protection by Enclosure "t"	
Ratings	
D2xC2LD3:	Class I Zone 2 AEx ec IIC Gc T4 Ta -40°C to +50°C AEx tc IIIC T75°C Dc Ta -40°C to +50°C
Installation must be carried out in compliance with the National Electric Code.	

CEC Class / Zone ratings Canada

Standards	
CAN/CSA C22.2 No. 60079-0 (Ed. 4) 02/2019 Explosive Atmospheres - Part 0: Equipment - General Requirements CAN/CSA C22.2 No. 60079-7 (Ed. 2) Explosive Atmospheres - Equipment Protection by Increased Safety "e" CAN/CSA C22.2 No. 60079-31 (Ed. 2) Explosive Atmospheres - Equipment Dust Ignition Protection by Enclosure "t"	
Rating	
D2xC2LD3:	Ex ec IIC Gc X T4 Ta -40°C to +50°C Ex tc IIIC T75°C Dc X Ta -40°C to +50°C
Installation must be carried out in compliance with the Canadian Electric Code	

4) Zones, Gas / Dust Groups and Temperature Classification

When connected to an approved system the D2XC2LD3 LED beacon may be installed in:

Area Classification	
Zone 2	Explosive gas air mixture not likely to occur in normal operation, and if it does, it will only exist for a short time.
Zone 22	Explosive dust air mixture not likely to occur in normal operation, and if it does, it will only exist for a short time.
Gas Groupings	
Group IIA	Propane
Group IIB	Ethylene
Group IIC	Hydrogen and Acetylene
Temperature Classification for Gas Applications	
T1	450°C
T2	300°C
T3	200°C
T4	135°C
Dust Groupings (ATEX / IECEx / UKEX only)	
Group IIIA	Combustible Flyings
Group IIIB	Non-conductive Dust
Group IIIC	Conductive Dust
Maximum Surface Temperature for Dust Applications (ATEX / IECEx / UKEX only)	
D2xC2LD3:	75°C
Equipment Category	
3G / 3D	
Equipment Level Protection	
Gc, Dc	
Ambient Temperature Range	
-40°C to +50°C	
IP Rating	
IP6X to EN/IEC60079-0 IP66 to EN60529 To maintain the ingress protection rating, the two off cable entries must be fitted with suitably rated, certified cable entry and/or blanking devices during installation.	
Type Rating	
Per UL50E / NEMA250: 4 / 4X / 3R / 13	

Installation must be carried out in compliance with the latest issue of the following standards:

EN60079-14 / IEC60079-14: Explosive atmospheres - Electrical installations design, selection and erection
 EN60079-10-1 / IEC60079-10-1: Explosive atmospheres - Classification of areas. Explosive gas atmospheres
 EN60079-10-2 / IEC60079-10-2: Explosive atmospheres - Classification of areas. Explosive dust atmospheres

5) Special Conditions for Safe Use

Special Condition for safe Use as stated on the Type Examination Certificate DEMKO 14 ATEX 4786493904X / CoC/IECEX ULD 14.0004X / UL21UKEX2131X:

When used for a Group III application, the surface of the enclosure may store electrostatic charge and become a source of ignition in applications with a low relative humidity <~30% relative humidity where the surface is relatively free of surface contamination such as dirt, dust, or oil.

Guidance on protection against the risk of ignition due to electrostatic discharge can be found in EN TR50404 and IEC TR60079-32.

End user shall adhere to the manufacturer's installation and instruction when performing housekeeping to avoid the potential for hazardous electrostatic charges during cleaning, by using a damp cloth.

To maintain the ingress protection rating and mode of protection, the cable entries must be fitted with suitably rated, certified cable entry and/or blanking devices during installation.

The equipment shall only be used in an area of at least pollution degree 2, as defined in IEC 60664-1.

6) Product Mounting and Access

6.1. Location and Mounting

The location of the combined alarm horn and beacon should be made with due regard to the area over which the warning signal must be visible and audible. It should only be fixed to services that can carry the weight of the unit.

DxC2 Alarm Horn and Strobe to a flat surface via the two 9.7 x 6.7mm, 147mm pitch fixing holes in the mounting feet of the sounder section and the two 7mm fixing holes in the feet of the base.

The equipment is not to be mounted with the horn facing upwards.

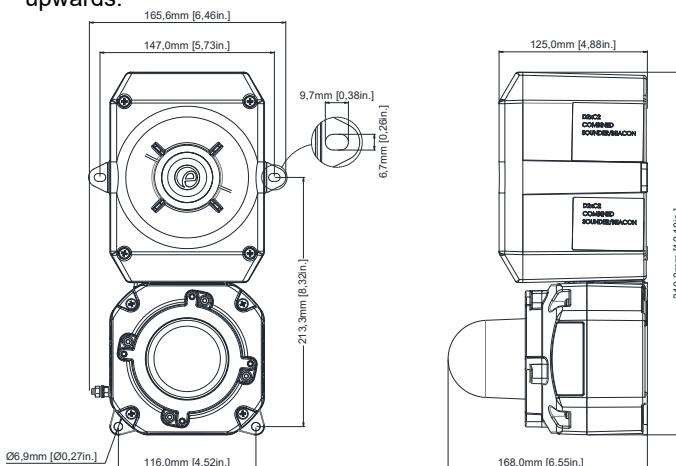

Fig. 1 Fixing locations.

6.2. Access to the Enclosure



Warning – High voltage may be present, risk of electric shock. DO NOT open when energised, disconnect power before opening.



Warning – Hot surfaces. External surfaces and internal components may be hot after operation, take care when handling the equipment.

To access the enclosures, loosen the four M4 posi pan head screws of the beacon and loosen the four M4 posi pan head screws of the sounder and withdraw the covers.

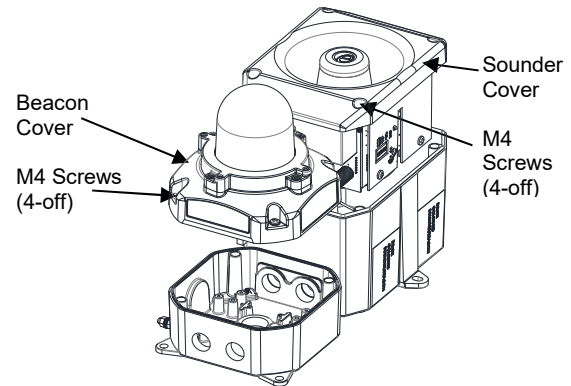

Fig. 2 Accessing the Enclosures.

To replace covers, check that the 'O' ring seals are in place. Carefully push the covers in place. Insert M4 screws with fibre washers and tighten to 3Nm torque.

7) Selection of Cable, Cable Glands, Blanking Elements & Adapters

When selecting the cable size, consideration must be given to the input current that each unit draws (see Table 1), the number of units on the line and the length of the cable runs. The cable size selected must have the necessary capacity to provide the input current to all of the sounders connected to the line.

When selecting the cable size consideration must be given to the voltage drop over the length of the cable run to ensure the min. input voltage at the point of use (voltage range, see section 15)

The voltage drop depends on:

- The total current draw of the devices installed on this cable run
- The wire size and total length of the cable run, determining the total resistance of this cable run
- The minimum output voltage supplied by the power supply

The voltage drop and input voltage at the point of use can be calculated as follows:

$$\text{Total Wire resistance} = \text{Wire resistance} / 1000\text{ft} \times \text{length of cable run} \times 2$$

(length of cable run needs to be multiplied by two to account for two wires going to and from the unit)

$$\text{Total current draw} = \text{Current draw per unit} \times \text{number of units}$$

$$\text{Voltage Drop} = \text{Total current draw} \times \text{Total wire resistance}$$

$$\text{Minimum output of power supply} = \text{Min. voltage at point of use} + \text{voltage drop}$$

The entries are available as one of the following options:

2-off M20 x 1.5 thread & 1-off 3/4" NPT thread;

2-off ½" NPT thread & 1-off ¾" NPT thread

If a high IP (Ingress Protection) rating is required then a suitable sealing washer must be fitted under the cable glands or blanking plugs.

For use in explosive dust atmospheres, a minimum ingress protection rating of IP6X must be maintained.

For use in explosive gas atmospheres, a minimum ingress protection rating of IP54 must be maintained.

NPT plugs should be greased before insertion.

8) Cable Connections

Electrical connections are to be made into the terminal blocks on the PCBAs located in the enclosures. See section 6 of this manual for access to the enclosures.

The Sounder and Beacon are supplied connected by default. In order to power the beacon and sounder separately, the link wires between the units must be disconnected.

Wires having a cross sectional area between 0.5 mm² to 2.5mm² can be connected to each terminal way. If an input and output wire is required the 2-off +/- terminals of the beacon or 3-off +/- terminals of the sounder can be used. If fitting 2-off wires to one terminal way the sum of the 2-off wires must be a maximum cross sectional area of 2.5mm². Strip wires to 8mm. Wires may also be fitted using ferrules. Terminal screws need to be tightened down with a tightening torque of 0.56 Nm / 5 Lb-in. When connecting wires to the terminals great care should be taken to dress the wires so that when the cover is inserted into the chamber the wires do not exert excess pressure on the terminal blocks. This is particularly important when using cables with large cross sectional areas such as 2.5mm².

9) Wiring

The beacon is powered via factory installed wires connected to the alarm horn. The wires connecting the alarm horn and strobe can be removed if the user wishes to power the strobe separately. For further wiring schematics refer to document D211-06-651

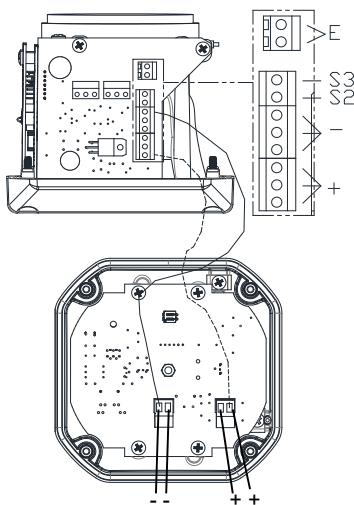

Fig. 4 Terminals

10) Earthing

The beacon has both internal and external earth points, (please see fig 5). The sounder PCBA also has earth terminals, (see fig 4).

Internal earthing connections should be made to the internal earth point on the beacon, (please see fig 5). The earth conductor should be at least equal in size and rating to the incoming power conductors. The internal earth bonding wires connect the covers to the internal earth points in the bases.

External earth connections should be made to the M5 earth stud, using a ring crimp terminal to secure the earth conductor to the earth stud. The external earth conductor should be at least 4mm² in size. The external earth crimp ring should be located between the two M5 plain washers provided and securely locked down with the M5 spring washer and M5 nut.

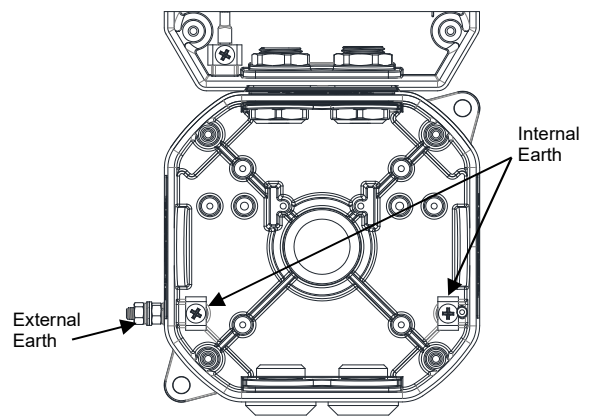

Fig. 5 Earth locations

11) End Of Line Monitoring

On Dx2 DC units, dc reverse line monitoring can be used if required. All DC units have a blocking diode fitted in their supply input lines. An end of line monitoring resistor can be connected across the +ve and -ve terminals. If an end of line resistor is used it must have the following values:-

Min. Resistance	Min. Power
3.9KΩ	0.5W
1KΩ	2W

The resistor must be connected directly across the +ve and -ve terminals of the PCBA, as shown in the following diagrams. Whilst keeping its leads as short as possible, a spacing of at least 1/16 inch (1.58mm) must be provided through air and over surfaces between uninsulated live parts.

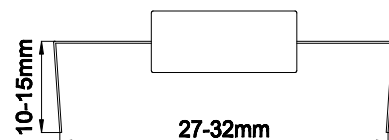

Fig. 6a End of Line Resistor Forming

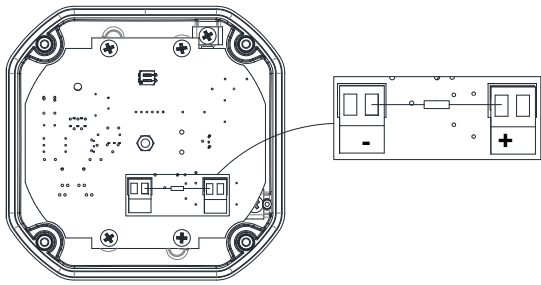

Fig. 6b End of Line Resistor Placement - Beacon

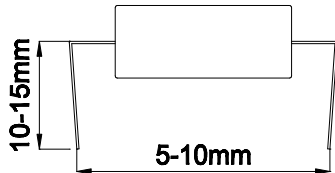

Fig. 7a End of Line Resistor Forming

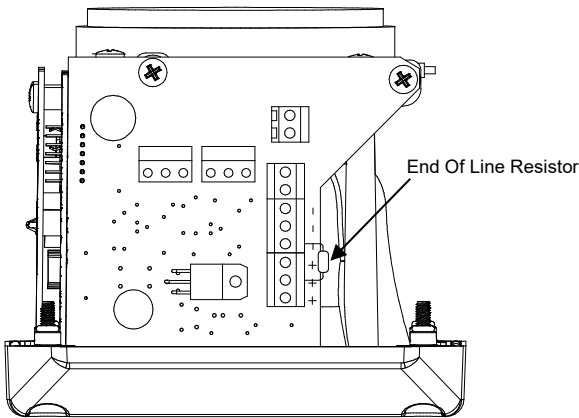

Fig. 7b End of Line Resistor Placement – Sounder

the 64 tone and which tones are available for the second, third and fourth stages.

12.3. Flash Rate Setting



Warning – high-intensity light source. Avoid looking directly at the light source for extended periods of time.

The D2xC2LD3 beacons can produce different flash patterns as shown in Table 1. The flash patterns are selected by operation of the flash setting DIP switch on the PCB, Fig 10.

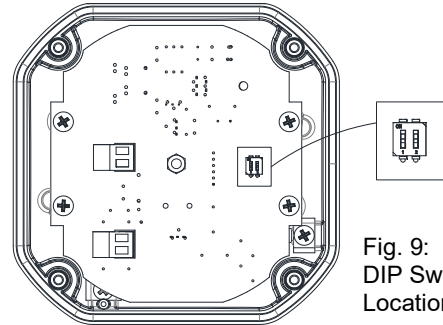

Fig. 9: DIP Switch Location

Switch Setting	Mode
00	1Hz (60FPM)
01	1.33Hz (80FPM)
10	1.5Hz (90FPM)
11	2Hz (120FPM)

1=ON; 0=OFF

Table 1: Switch Positions for Flash Patterns

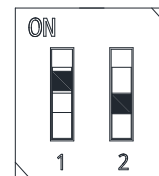

Fig. 10 Dip Switch

Example shown: 01 = Flashing 1.33Hz

13) Maintenance, Overhaul & Repair

Maintenance, repair and overhaul of the equipment should only be carried out by suitably qualified personnel in accordance with the current relevant standards:

- IEC/EN60079-19 Explosive atmospheres - Equipment repair, overhaul and reclamation
- IEC/EN60079-17 Explosive atmospheres - Electrical installations inspection and maintenance

To avoid a possible ELECTROSTATIC CHARGE the unit must only be cleaned with a damp cloth.

Units must not be opened while an explosive atmosphere is present.

If opening the unit during maintenance operations a clean environment must be maintained and any dust layer removed prior to opening the unit.

12) Setting

12.1. Volume Control

The alarm horn output level of the DxC2 unit can be set by adjusting the volume control potentiometer (see Fig 8). For maximum output, set the potentiometer fully clockwise.

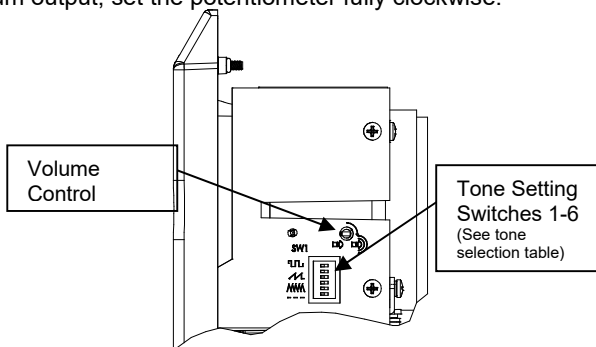

Fig. 8 Location of field controls

12.2. Tone Selection

The DxC2 alarm horns have 64 different tones. The tones are selected by operation of the tone setting DIP switches (see Fig. 9 & 10) on the PCB. The alarm horns can also be switched to sound the second, third and fourth stage alarm tones. The tone table (Table 1) shows the switch positions for

14) Electrical Ratings

14.1 Operating current Consumption

Table 6 – Electrical Ratings



Model	Nom. Voltage	Voltage Range	Flash Rate Setting	Nom. operating current [#]		Max. operating current ^{##}	
				Beacon	Sounder	Beacon	Sounder
D2xC2LD3DC024	24Vdc	Regulated (16-33Vdc)*	Flashing 1Hz	153mA	250mA	465mA	250mA
			Flashing 1.33Hz	189mA		488mA	
			Flashing 1.5Hz	203mA		456mA	
			Flashing 2Hz	248mA		528mA	



* For Public Mode or private mode Fire Alarm or General Signaling use

nominal rms current at nominal voltage

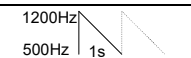
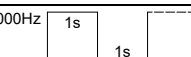
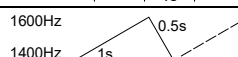
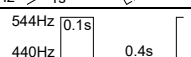
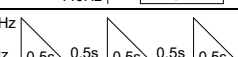
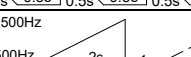
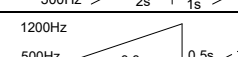
max. rms current at worst-case voltage in voltage range.

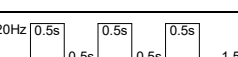
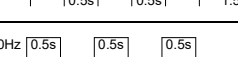
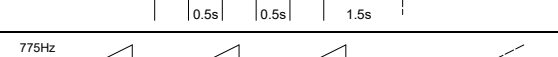
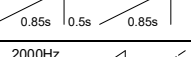
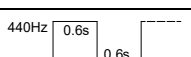
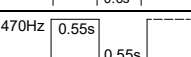
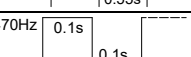
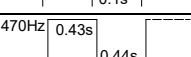
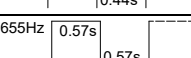
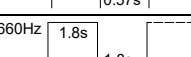
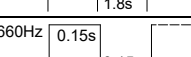
15) Tone Table

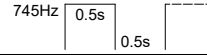
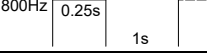
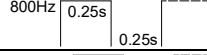
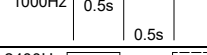
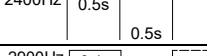
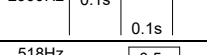
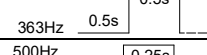
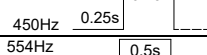
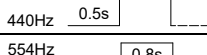
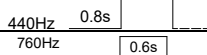
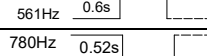
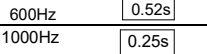
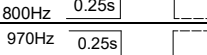
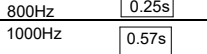
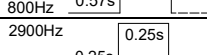
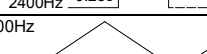
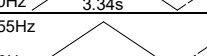
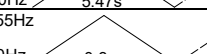
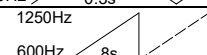
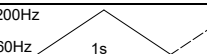
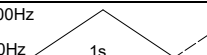
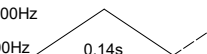
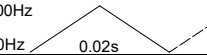
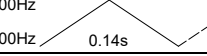
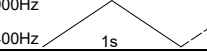
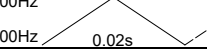
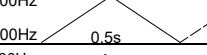
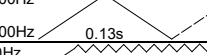
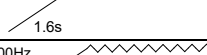
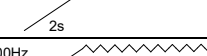
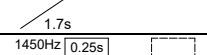
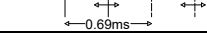
Tone Selection – To select the required first stage tone set the tone switches 1 to 6 (see Fig 2) to the tone setting shown in the table below. The table also shows which 2 nd , 3 rd and 4 th stage tones are available for use with the selected first stage tone if more than one tone output stage is required.						
Stage 1 Tone No	Tone Description	Tone Visual	Switch Settings 1 2 3 4 5 6	Stage 2 Tone (S2)	Stage 3 Tone (S3)	Stage 4 Tone (S2 + S3)
1	1000Hz PFEER Toxic Gas	1000Hz _____	0 0 0 0 0	3	2	44
2	1200/500Hz @ 1Hz DIN / PFEER P.T.A.P.		1 0 0 0 0	1	3	44
3	1000Hz @ 0.5Hz(1s on, 1s off) PFEER Gen. Alarm		0 1 0 0 0	1	2	44
4	1.4KHz-1.6KHz 1s, 1.6KHz-1.4KHz 0.5s NF C 48-265		1 1 0 0 0	44	24	1
5	544Hz(100mS)/440Hz (400mS) NF S 32-001		0 0 1 0 0	52	19	1
6	1500/500Hz - (0.5s on , 0.5s off) x3 + 1s gap AS4428		1 0 1 0 0	7	44	1
7	500-1500Hz Sweeping 2 sec on 1 sec off AS4428		0 1 1 0 0	6	44	1
8	500/1200Hz @ 0.26Hz(3.3s on, 0.5s off) Netherlands - NEN 2575		1 1 1 0 0	44	24	35
9	1000Hz (1s on, 1s off)x7 + (7s on, 1s off) IMO Code 1a		0 0 0 1 0 0	18	34	1
10	1000Hz (1s on, 1s off)x7 + (7s on, 1s off) IMO Code 1a		1 0 0 1 0 0	21	34	1
11	420Hz(0.5s on, 0.5s off)x3 + 1s gap ISO 8201 Temporal Pattern		0 1 0 1 0 0	44	1	8
12	1000Hz(0.5s on, 0.5s off)x3 + 1s gap ISO 8201 Temporal Pattern		1 1 0 1 0 0	44	1	8
13	422/775Hz - (0.85s on, 0.5 off) x3 + 1s gap NFPA - Temporal Coded		0 0 1 1 0 0	44	1	8
14	1000/2000Hz @ 1Hz Singapore		1 0 1 1 0 0	23	3	35
15	300Hz Continuous	300Hz _____	0 1 1 1 0 0	44	24	35
16	440Hz Continuous	440Hz _____	1 1 1 1 0 0	44	24	35
17	470Hz Continuous	470Hz _____	0 0 0 0 1 0	44	24	35
18	500Hz Continuous IMO code 2 (Low)	500Hz _____	1 0 0 0 1 0	44	24	35
19	554Hz Continuous	554Hz _____	0 1 0 0 1 0	64	24	35
20	660Hz Continuous	660Hz _____	1 1 0 0 1 0	44	24	35
21	800Hz IMO code 2 (High)	800Hz _____	0 0 1 0 1 0	44	24	35
22	1200Hz Continuous	1200Hz _____	1 0 1 0 1 0	44	24	35
23	2000Hz Continuous	2000Hz _____	0 1 1 0 1 0	15	3	35
24	2400Hz Continuous	2400Hz _____	1 1 1 0 1 0	48	20	35
25	440 @0.83Hz (50 cycles/minute) Intermittent		0 0 0 1 1 0	1	44	8
26	470 @0.9Hz - 1.1s Intermittent		1 0 0 1 1 0	1	44	8
27	470Hz @5Hz - (5 cycles/second) Intermittent		0 1 0 1 1 0	1	44	8
28	544Hz @ 1.14Hz - 0.875s Intermittent		1 1 0 1 1 0	44	24	8
29	655Hz @ 0.875Hz Intermittent		0 0 1 1 1 0	1	44	8
30	660Hz @0.28Hz - 1.8sec on, 1.8sec off Intermittent		1 0 1 1 1 0	44	24	8
31	660Hz @3.34Hz - 150mS on, 150mS off Intermittent		0 1 1 1 1 0	30	24	8

32	745Hz @ 1Hz Intermittent		1 1 1 1 1 0	44	24	8
33	800Hz - 0.25sec on, 1 sec off Intermittent		0 0 0 0 0 1	53	24	8
34	800Hz @ 2Hz IMO code 3.a (High) Intermittent		1 0 0 0 0 1	56	24	8
35	1000Hz @ 1Hz Intermittent		0 1 0 0 0 1	44	24	8
36	2400Hz @ 1Hz Intermittent		1 1 0 0 0 1	21	24	8
37	2900Hz @ 5Hz Intermittent		0 0 1 0 0 1	53	24	8
38	363/518Hz @ 1Hz Alternating		1 0 1 0 0 1	1	8	19
39	450/500Hz @ 2Hz Alternating		0 1 1 0 0 1	1	8	19
40	554/440Hz @ 1Hz Alternating		1 1 1 0 0 1	44	24	19
41	554/440Hz @ 0.625Hz Alternating		0 0 0 1 0 1	1	8	19
42	561/760Hz @ 0.83Hz (50 cycles/minute) Alternating		1 0 0 1 0 1	1	8	19
43	780/600Hz @ 0.96Hz Alternating		0 1 0 1 0 1	1	8	19
44	800/1000Hz @ 2Hz Alternating		1 1 0 1 0 1	5	24	19
45	970/800Hz @ 2Hz Alternating		0 0 1 1 0 1	1	8	19
46	800/1000Hz @ 0.875Hz Alternating		1 0 1 1 0 1	53	24	19
47	2400/2900Hz @ 2Hz Alternating		0 1 1 1 0 1	57	24	19
48	500/1200Hz @ 0.3Hz Sweeping		1 1 1 1 0 1	44	24	12
49	560/1055Hz @ 0.18Hz Sweeping		0 0 0 0 1 1	44	24	12
50	560/1055Hz @ 3.3Hz Sweeping		1 0 0 0 1 1	44	24	12
51	600/1250Hz @ 0.125Hz Sweeping		0 1 0 0 1 1	44	24	12
52	660/1200Hz @ 1Hz Sweeping		1 1 0 0 1 1	64	24	12
53	800/1000Hz @ 1Hz Sweeping		0 0 1 0 1 1	56	24	12
54	800/1000Hz @ 7Hz Sweeping		1 0 1 0 1 1	57	24	12
55	800/1000Hz @ 50Hz Sweeping		0 1 1 0 1 1	54	24	12
56	2400/2900Hz @ 7Hz Sweeping		1 1 1 0 1 1	57	24	12
57	2400/2900Hz @ 1Hz Sweeping		0 0 0 1 1 1	47	24	12
58	2400/2900Hz @ 50Hz Sweeping		1 0 0 1 1 1	54	24	12
59	2500/3000Hz @ 2Hz Sweeping		0 1 0 1 1 1	44	24	12
60	2500/3000Hz @ 7.7Hz Sweeping		1 1 0 1 1 1	44	24	12
61	800Hz Motor Siren		0 0 1 1 1 1	44	24	12
62	1200Hz Motor Siren		1 0 1 1 1 1	44	24	12
63	2400Hz Motor Siren		0 1 1 1 1 1	44	24	12
64	Simulated Bell		1 1 1 1 1 1	44	21	12

FIRE INSTRUCTION MANUAL

D2xC2LD2 Alarm Horn and LED

For use in Hazardous Locations



1) Warnings

- DO NOT PAINT



Avertissement:

- NE PAS PEINTURER

2) Rating & Marking Information

2.1 Public Mode Fire Alarm Ratings

The D2xC2LD2DC024 is certified for use as a public mode audible and visual alarm device in accordance with UL464 & UL1971 / UL1638.

For use in public-mode fire alarm systems the equipment must be installed without the wire guard or plastic lens cover on the beacon.

The beacon must be set to one of the certified flash patterns of 1Hz, 1.33Hz or 2Hz (for DIP switch settings see section 10).

For light output ratings of the beacon see section 12.

The sounder section produces a sound pressure level above 75dB(A) at 10 feet:

For Fire Alarm applications, the Sounder Volume must be at the highest setting, (see volume control section).

For fire alarm use, the temporal pattern tone No. 12 as per the tone table provided in these instructions must be selected. This tone produces a minimum sound pressure level of:

CAN/ULC-S525: 100.4dB(A)* at 10 feet.

(*anechoic room)

UL464: 92.2dB(A)[†] at 10 feet.

([†]reverberation room)

Testing of synchronization requirements of UL1971 & UL1638 / CAN/ULC-S526 were conducted by UL using a total of 6 units connected to the same wire run. Auto-synchronization does not require the use of any external sync modules or protocols. Providing the correct cable has been selected (see section 6) an unlimited number of units will remain synchronized when powered from the same source.

2.2 Private Mode Fire Alarm Ratings

The D2xC2LD2DC024 is approved for use as Audible and Visual Appliance for use in Fire Alarm Systems – Private Mode.

For private mode fire alarm use the beacons must only be fitted with clear or red plastic lens covers and must be set to one of the certified flash patterns of 1Hz, 1.33Hz or 2Hz.

For light output ratings see section .

3) Light output for Fire alarm use

In order to meet the requirements for UL 1971, (D2xC2LD2DC024 when used with 1Hz, 1.33Hz or 2Hz Flash rates and without plastic lens cover and wire guard only), the installation must be carried out to the correct NFPA standards and guidelines.

3.1 Horizontal Light Output Dispersion for wall mounting – public mode

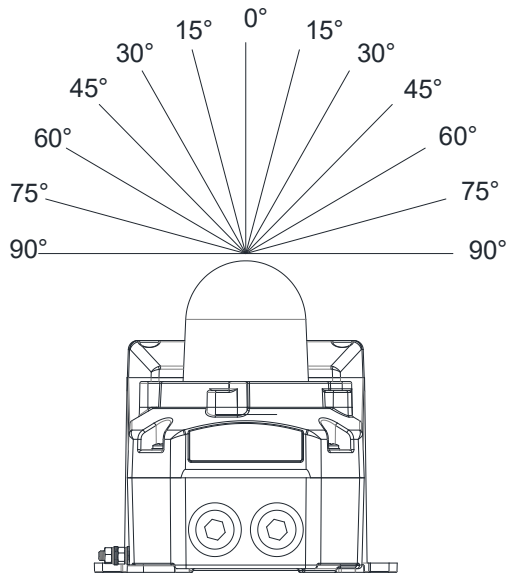

Fig. 1 – Horizontal dispersion angles for wall mounting

Table 1 - Horizontal Light Output Dispersion for Wall Mounting				
Viewing Angle	% Of Rating	Intensity (cd) at 1Hz flash rate	Intensity (cd) at 1.33Hz flash rate	Intensity (cd) at 2Hz flash rate
0°	100	38.38	35.87	25.97
5-25°	90	34.54	32.28	23.37
30-45°	75	28.79	26.90	19.48
50°	55	21.11	14.28	14.28
55°	45	17.27	11.69	11.69
60°	40	15.35	10.39	10.39
65°	35	13.43	9.09	9.09
70°	35	13.43	9.09	9.09
75°	30	11.51	7.79	7.79
80°	30	11.51	7.79	7.79
85°	25	9.60	6.49	6.49
90°	25	9.60	6.49	6.49
Compound 45° to Right	24	9.21	8.61	6.23
Compound 45° to Left	24	9.21	8.61	6.23

3.2 Vertical Light Output Dispersion for wall mounting – public mode

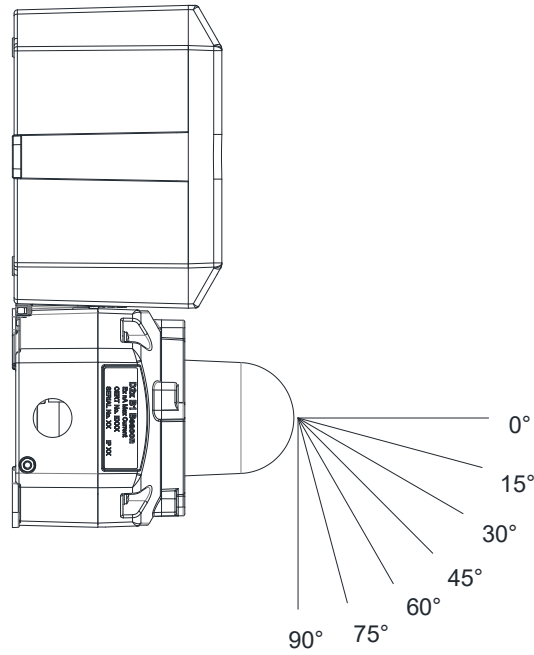

Fig. 2 – Vertical dispersion angles for wall mounting

Table 2 - Vertical Light Output Dispersion for Wall Mounting				
Viewing Angle	% Of Rating	Intensity (cd) at 1Hz flash rate	Intensity (cd) at 1.33Hz flash rate	Intensity (cd) at 2Hz flash rate
0°	100	38.38	35.87	25.97
5-30°	90	34.54	32.28	23.37
35°	65	24.95	23.32	16.88
40°	46	17.65	16.50	11.95
45°	34	13.05	12.20	8.83
50°	27	10.36	9.68	7.01
55°	22	8.44	7.89	5.71
60°	18	6.91	6.46	4.67
65°	16	6.14	5.74	4.16
70°	15	5.76	5.38	3.90
75°	13	4.99	4.66	3.38
80-90°	12	4.61	4.30	3.12

3.3 Vertical Light Output Dispersion for ceiling mounting – public mode

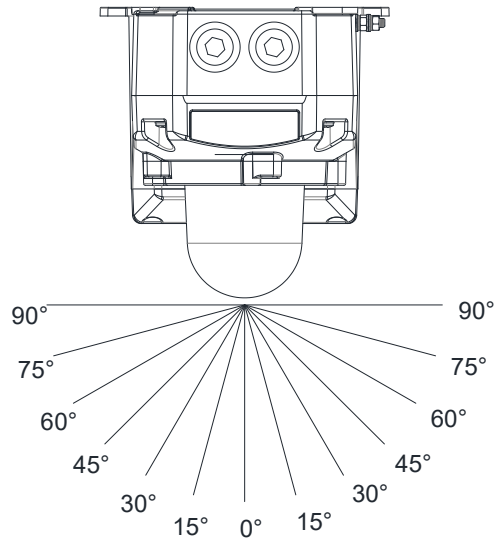

Fig. 3 – Vertical dispersion angles for ceiling mounting

Table 3 – Vertical Light Output Dispersion for Ceiling Mounting				
Viewing Angle	% Of Rating	Intensity (cd) at 1Hz flash rate	Intensity (cd) at 1.33Hz flash rate	Intensity (cd) at 2Hz flash rate
0°	100	38.38	35.87	25.97
5-25°	90	34.54	32.28	23.37
30-45°	75	28.79	26.90	19.48
50°	55	21.11	19.73	14.28
55°	45	17.27	16.14	11.69
60°	40	15.35	14.35	10.39
65°	35	13.43	12.55	9.09
70°	35	13.43	12.55	9.09
75°	30	11.51	10.76	7.79
80°	30	11.51	10.76	7.79
85°	25	9.60	8.97	6.49
90°	25	9.60	8.97	6.49

All light output ratings min. values as per UL 1971 / UL1638 / CAN/ULC-S526 at worst-case (min.) input voltage.

3.4 On-axis light output rating – private mode

Table 5 – Vertical Light Output Dispersion for Ceiling Mounting		
Model	Lens Cover Colour	Intensity (cd) at 1Hz flash rate
D2xC2LD2DC024	clear	73.4
	red	67.27

4) Electrical Ratings

4.1 Surge current for Fire Alarm system use

Table 4 – Surge Currents					
Model	Nom. Voltage	Voltage Range	Flash Rate Setting	Init. Peak Surge Current (A)	Init. RMS Surge Current (mA)
D2xC2LD2DC024	24Vdc	Regulated 24 (16-33Vdc)*	1Hz (60fpm)	2.73	240
			1.33Hz (80 fpm)	2.75	214
			2Hz (120fpm)	2.33	204

5) Sound Directional Characteristics for Canadian Fire CAN/ULC-S525

Horizontal Axis

Angle	OSPL	Angle	OSPL
Reference (90°)	101.2 dB(A)	Reference (90°)	101.2 dB(A)
115°	-3 dB(A)	68°	-3 dB(A)
129°	-6 dB(A)	55°	-6 dB(A)
180°	92.4 dB(A)	0°	92.4

Vertical Axis

Angle	OSPL	Angle	OSPL
Reference (90°)	101.5 dB(A)	Reference (90°)	101.5 dB(A)
123°	-3 dB(A)	65°	-3 dB(A)
137°	-6 dB(A)	50°	-6 dB(A)
180°	91 dB(A)	0°	88.5 dB(A)

8	9	10
ISSUE	MOD No.	REASON - INITIAL - DATE
1		INTRODUCTION DH 17-05-2022

OPTIONAL LINE MONITORING RESISTOR, CUSTOMER SUPPLIED,
REQUIRED MINIMUM VALUES:
24VDC : 1KΩ MIN, 2W MIN OR 3K9Ω MIN, 0.5W MIN
48VDC : 3.9KΩ MIN, 2W MIN OR 15KΩ MIN, 0.5W MIN

----- WIRING LINKING BEACON & SOUNDER
FACTORY FITTED

TO OPERATE SOUNDER AND BEACON
INDEPENDENTLY, REMOVE FACTORY
FITTED WIRES LINKING THE UNITS

DC D2XC2LD3 UNITS

Line Monitoring

- Stage 1: Apply power to Sounder +ve & -ve
- Stage 2: Apply power to Sounder +ve & -ve. Connect Stage 2 to -ve
- Stage 3: Apply power to Sounder +ve & -ve. Connect Stage 3 to -ve
- Stage 4: Apply power to Sounder +ve & -ve. Connect Stage 2 and Stage 3 to -ve

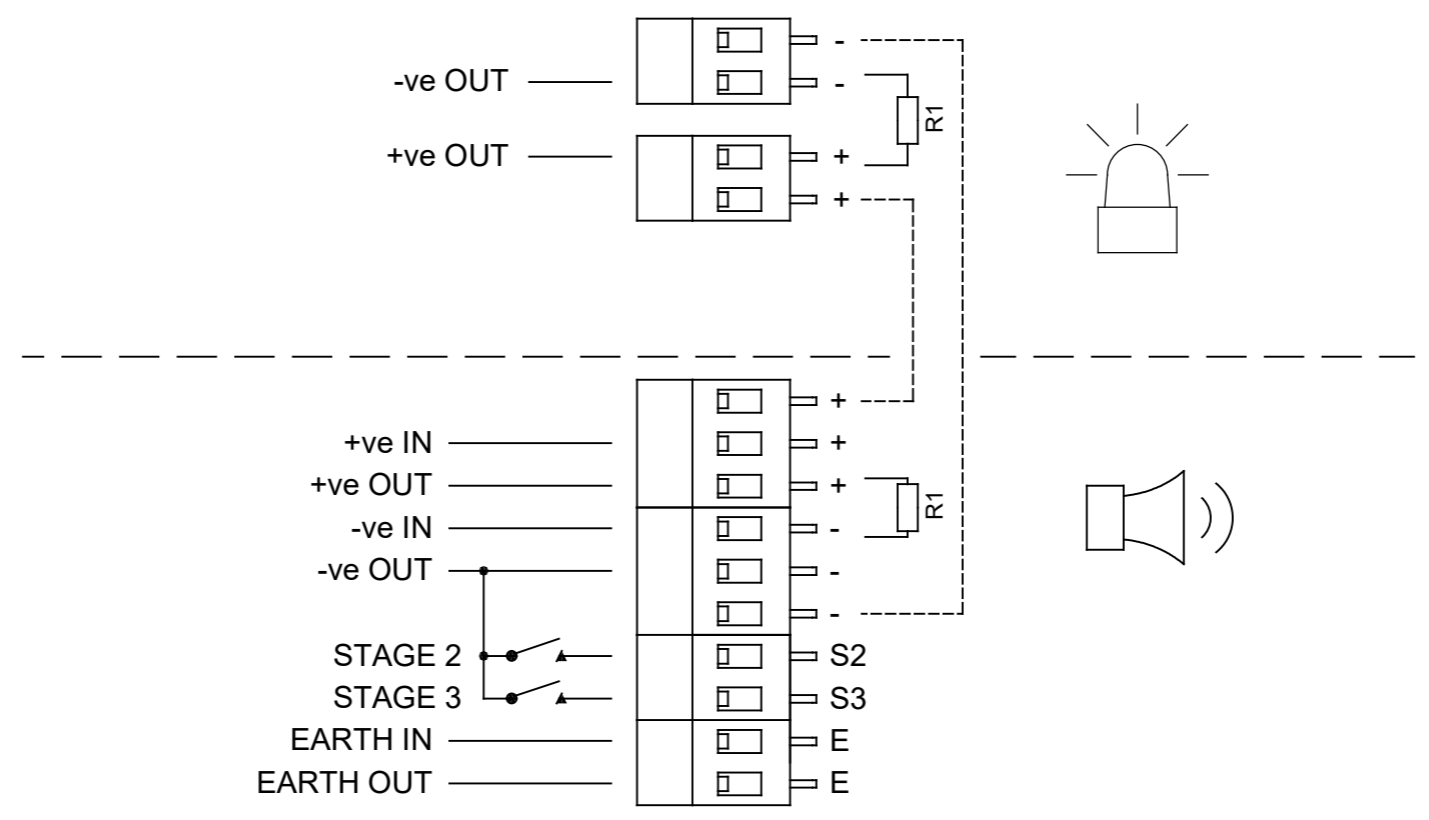

DRAWING TO BS8888:2000
GEOMETRIC TOLERANCES TO ISO1101:1983
LINEAR DIMENSIONAL TOLS +/-0.35mm
ANGULAR DIMENSIONAL TOLS +/-2 deg

DRAWN	DATE
D.HOWGILL	17-05-2022
CHECKED	DATE
B. ISARD	17-05-2022
APPROVED	DATE
R.N.POTTS	17-05-2022

SURFACE FINISH	WEIGHT (Kg)
MATERIAL	
ALTERNATIVE MATERIAL	

THIS DRAWING AND ANY INFORMATION OR DESCRIPTIVE
MATTER THEREIN IS COMMUNICATED IN CONFIDENCE AND IS
THE COPYRIGHT PROPERTY OF EUROPEAN SAFETY SYSTEMS
LTD. NEITHER THE WHOLE OR ANY EXTRACT MAY BE
DISCLOSED, LOANED, COPIED OR USED FOR MANUFACTURING
OR TENDERING PURPOSES WITHOUT THEIR WRITTEN
CONSENT.

© EUROPEAN SAFETY SYSTEMS LTD.
AS PER LATEST DATE OF ISSUE SHOWN ABOVE

e2s
warning signals

EUROPEAN SAFETY SYSTEMS LTD
IMPRESS HOUSE
MANSELL ROAD
ACTON
LONDON W3 7QH
WWW.E2S.COM

ALL DIMENSIONS IN MM IF IN DOUBT, ASK - DO NOT SCALE			A3
TITLE D2xC2LD3 PUBLIC MODE FIRE COMBINED BEACON AND SOUNDER WIRING DIAGRAM			
SCALE NTS	SHEET 1 OF 1	DRAWING NUMBER D211-06-671	

EU Declaration of Conformity



Manufacturer: European Safety Systems Ltd.
Impress House, Mansell Road, Acton
London, W3 7QH
United Kingdom

Authorised Representative: E2S Warnsignaltechnik UG
Charlottenstrasse 45-51
72764 Reutlingen
Germany

Equipment Type: D2xS1, D2xC1X05, D2xC1X10
D2xB1X05, D2xB1X10, D2xB1LD2, D2xB1XH1, D2xB1XH2, D2xB1LD3
D2xC2X05, D2xC2X10, D2xC2LD2, D2xC2XH1, D2xC2XH2, D2xC2LD3
D2xJ1

Directive 2014/34/EU: Equipment and Protective Systems for use in Potentially Explosive Atmospheres (ATEX)

Notified Body for EU type Examination (Module B):	UL International Demko A/S Notified Body No.: 0539 Borupvang 5A, 2750 Ballerup, Denmark
EU-type Examination Certificate (Module B):	DEMKO 14 ATEX 4786493904X
Notified Body for Quality Assurance Notification / Conformity to EU-type based on quality assurance of the production process (Module D):	Sira Certification Service Notified Body No.: 2813 CSA Group Netherlands B.V, Utrechtseweg 310, 6812 AR, Arnhem, Netherlands
Quality Assurance Notification (Module D):	SIRA 05 ATEX M342
Provisions fulfilled by the equipment:	II 3G Ex ec IIC T6/T4/T3/T2/T1 Gc II 3D Ex tc IIIC Ex tc IIIC T5/75/80/85/90/95/105/110°C Dc IP66 Ingress / Dust Protection to EN60079-0 / EN60079-31
Standards applied:	EN IEC 60079-0:2018 EN IEC 60079-7:2015 +A1:2018 EN 60079-31:2014

Directive 2014/30/EU: Electromagnetic Compatibility Directive (EMC)

Standards applied:	EN 61000-6-1:2007 EN 61000-6-2:2005 EN 61000-6-3:2007 / A1:2011 / AC: 2012 EN 61000-6-4:2007 / A1: 2011
--------------------	--

Directive 2011/65/EU: Restriction of the use of certain hazardous substances in electrical and electronic equipment (RoHS)

The product and all the components contained within it are in accordance with the restriction of the use of hazardous substances in electrical and electronic equipment, including amendment by Directive 2015/863/EU.

Regulation (EC) 1907/2006: Registration, Evaluation, Authorisation and Restriction of Chemicals (REACH)

The product and all the components contained within it are free from substances of very high concern.

Other Standards and Regulations

EN 60529:1992+A2:2013 - Degrees of protection provided by enclosures (IP code) – enclosure rated IP66

EU Declaration of Conformity



On behalf of European Safety Systems Ltd., I declare that, on the date the equipment accompanied by this declaration is placed on the market, the equipment conforms with all technical and regulatory requirements of the above listed directives, regulations and standards.

This Declaration is issued under the sole responsibility of the manufacturer.

A handwritten signature in black ink, appearing to read 'Martin Streetz'.

Martin Streetz
Quality Assurance Manager

Document No.: DC-061_Issue_J
Date and Place of Issue: London, 22/08/2022



UKCA Declaration of Conformity



Manufacturer: European Safety Systems Ltd.
Impress House, Mansell Road, Acton
London, W3 7QH
United Kingdom

Equipment Type: D2xS1, D2xC1X05, D2xC1X10
D2xB1X05, D2xB1X10, D2xB1LD2, D2xB1XH1, D2xB1XH2, D2xB1LD3
D2xC2X05, D2xC2X10, D2xC2LD2, D2xC2XH1, D2xC2XH2, D2xC2LD3
D2xJ1

Directive UKSI 2016:1107 (as amended by UKSI 2019:696) – Schedule 3A, Part 1 : Product or Protective System Intended for use in Potentially Explosive Atmospheres (UKCA)

Notified Body for UK type Examination (Module B):	UL International (UK) Ltd Notified Body No.: 0843 Unit 1-3 Horizon Kingsland Business Park, Wade Road, Basingstoke, Hampshire RG24 8AH UK
UK-type Examination Certificate (Module B):	UL21UKEX2131X
Notified Body for Quality Assurance Notification / Conformity to EU-type based on quality assurance of the production process (Module D):	Sira Certification Service Notified Body No.: 0518 Rake Lane, Eccleston, Chester CH4 9JN, UK
Quality Assurance Notification (Module D):	CSAE 22UKQAN0046
Provisions fulfilled by the equipment:	II 3G Ex ec IIC T6/T4/T3/T2/T1 Gc II 3D Ex tc IIIC Ex tc IIIC T5/75/80/85/90/95/105/110°C Dc IP66 Ingress / Dust Protection to EN60079-0 / EN60079-31
Standards applied:	EN IEC 60079-0:2018 EN IEC 60079-7:2015 +A1:2018 EN 60079-31:2014

Directive 2014/30/EU: Electromagnetic Compatibility Directive (EMC)

Standards applied:	EN 61000-6-1:2007 EN 61000-6-2:2005 EN 61000-6-3:2007 / A1:2011 / AC: 2012 EN 61000-6-4:2007 / A1: 2011
--------------------	--

Directive 2011/65/EU: Restriction of the use of certain hazardous substances in electrical and electronic equipment (RoHS)

The product and all the components contained within it are in accordance with the restriction of the use of hazardous substances in electrical and electronic equipment, including amendment by Directive 2015/863/EU.

Regulation (EC) 1907/2006: Registration, Evaluation, Authorisation and Restriction of Chemicals (REACH)

The product and all the components contained within it are free from substances of very high concern.

Other Standards and Regulations

EN 60529:1992+A2:2013 - Degrees of protection provided by enclosures (IP code) – enclosure rated IP66



UKCA Declaration of Conformity



On behalf of European Safety Systems Ltd., I declare that, on the date the equipment accompanied by this declaration is placed on the market, the equipment conforms with all technical and regulatory requirements of the above listed directives, regulations and standards.

This Declaration is issued under the sole responsibility of the manufacturer.

Martin Streetz
Quality Assurance Manager

Document No.:
Date and Place of Issue:

DC-102_Issue_A
London, 22/08/2022