

GNExCP6C-PB Manual Call Point – Push Button With Resistor Modules For use in Flammable Gas and Combustible Dust Atmospheres.

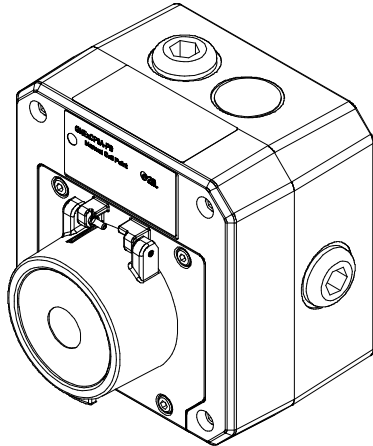

1) Introduction

The GNExCP6C-PB is a push button manual call point which is certified to the European and International Gas and Dust standards. The unit meets the requirements of the ATEX directive 2014/34/EU, IECEx and UKEX schemes.

The call point can be used in hazardous areas where potentially flammable gas and dust atmospheres may be present.

All units have up to two of the following:

- Monitoring resistors up to 1.5W per module
- Monitoring diode
- Monitoring Zener diode

Units may also incorporate an LED indicator in addition to the two series and/ or EOL devices allowed.

The units are Group II, EPL (equipment protection level) Gb. The equipment is certified 'Ex db eb mb IIC T4 Gb' and as such may be used in Zones 1 and 2 with flammable gases and vapours with gas groups IIA, IIB & IIC and temperature classes T1, T2, T3 and T4.

These units are also Group III, EPL Db. The equipment is certified 'Ex tb IIIC T75°C Db' and as such may be used in Zones 21 and 22 for combustible dusts groups IIIA, IIIB & IIIC.

2) Ratings & Markings

All units have a rating label, which carries the following important information: -

Unit Type No.:
GNExCP6C-PB Manual Call Point

Input Voltages:

Important: See section 7.1 for current ratings

| | |
|------------|---|
| 125VDC Max | 0.5A Max. Resistive Load; 0.03A Max Inductive Load |
| 75VDC Max | 0.75A Max |
| 48VDC Max | 1.0A Max |
| 24VDC Max | 5.0A Max Resistive Load; 3.0A Max Inductive Load |
| 12VDC Max | 5.0A Max |
| 6VDC Max | 5.0A Max |

Code:
GNExCP6C-PB
Ex db eb mb IIC T4 Gb
Ex tb IIIC T75°C Db
IP66
-40°C <= Ta <= +65°C

Certificate No.:
SIRA 09ATEX3286X
IECEx SIR 09.0121X
CSAE 21UKEX3556X

Epsilon x:  II 2GD

CE Marking
Notified
Body No.  2813

UKCA Marking
Notified Body No.  0518

Year/Serial No. i.e. 20/1CP6CPB000001

**WARNING - DO NOT OPEN WHEN AN
EXPLOSIVE ATMOSPHERE MAY BE PRESENT,
ELECTROSTATIC HAZARD – CLEAN ONLY
WITH A DAMP CLOTH**

3) Type Approval Standards

The call point has an EC Type examination certificate issued by SIRA and have been approved to the following standards: -

EN60079-0:2018 / IEC60079-0:2017
EN60079-1:2014 / IEC60079-1:2014
EN60079-7:2015 / IEC60079-7:2017
EN60079-18:2015 / IEC60079-18:2014
EN60079-31:2014 / IEC60079-31:2013

The equipment is certified for use in ambient temperatures in the range:
GNExCP6C-PB -40°C to +65°C
and shall not be used outside this range.

4) Installation Requirements

Installation of this equipment shall only be carried out by suitably trained personnel in accordance with the applicable code of practice e.g. IEC 60079-14/EN 60079-14

Repair of this equipment shall only be carried out by the manufacturer or in accordance with the applicable code of practice e.g. IEC 60079-19/EN 60079-19.

Refer to certificates SIRA 09ATEX3286X, IECEx SIR 09.0121X and CSAE 21UKEX3556X for special conditions of safe use.

The certification of this equipment relies on the following materials used in its construction:

Enclosure: GRP - Glass Reinforced Polyester

Through enclosure mechanism: Plastic Nylon Zytel Injection Moulded

Sealing of enclosure and mechanism: O-ring Acrylonitrile-Butadiene Rubber

Potting Compound of resistors where used: Epoxy Resin

If the equipment is likely to come into contact with aggressive substances, then it is the responsibility of the user to take suitable precautions that prevent it from being adversely affected, thus ensuring that the type of protection is not compromised.

"Aggressive substances" - e.g. acidic liquids, gases or solvents that may affect polymeric materials.

"Suitable precautions" - e.g. regular checks as part of routine inspections or establishing from the material's data sheet that it is resistant to specific chemicals.

Under extreme conditions the unit may generate an ignition-capable level of electrostatic charges. The unit must not be installed in a location where it may be subjected to external conditions (such as high-pressure steam) which may cause a build-up of electrostatic charges on non-conducting surfaces.

Cleaning of the unit must only be carried out with a damp cloth.

5) Call Point Location and Mounting

The location of the call point should enable ease of access for operation and testing. The unit should be mounted using the 4 off fixing holes which will accept up to M5 sized fixings.

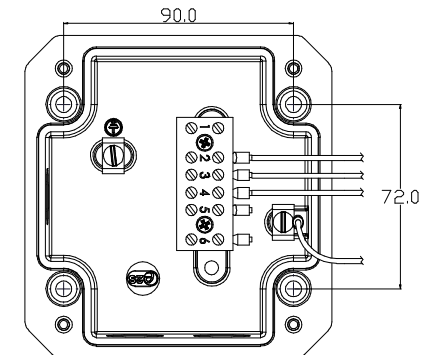

View of base unit showing fixing centres (in mm).

To gain access to the mounting holes in the base the front cover must be removed.

This is achieved by removing the 4 off M4 cap head bolts holding on the cover.

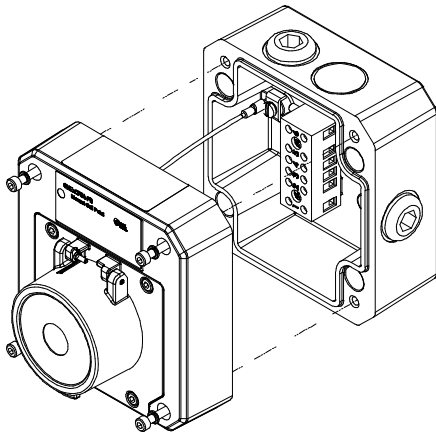

Once the screws are removed the cover will hang down out of the way to gain access to the Ex e terminal block, the internal earth terminal and mounting hole recesses.

6) Earthing

The unit has an internal earth terminal. It is recommended that a cable crimp lug is used on the earth wires. The internal earth wire is placed under an earth clamp which will stop the cable twisting. This is secured by an M4 screw and spring washer.

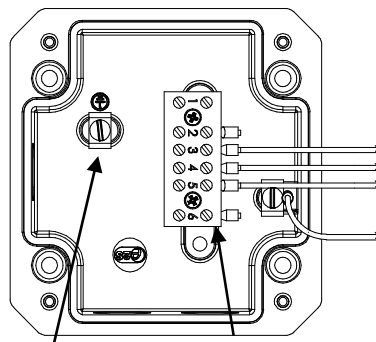

Internal Earth terminal Ex e terminal block

7) Cable connections

There are 3 off cable entries for M20x1.5 Ex e approved cable glands or stopping plugs with a minimum ingress protection of IP66

The unit can be wired in a number of different ways depending on the device combination selected.

EOL (End of line) device:
resistor – ExxxR / diode – ED1 / zener – ExxxZ
Series (In line) device:
resistor – SxxxR / diode – SD1 / zener – SxxxZ / LED
Microswitch 1 = M/S 1
Microswitch 2 = M/S 2

The unit can be wired with a maximum of 2 module devices – refer to wiring schematic D154-06-051

When wiring to Increased Safety terminal enclosures, you are only permitted to connect one wire into each way on the terminal block unless a pair of wires are crimped into a suitable ferrule. For the six-way terminal block wire sizes allowable are 0.5mm² to 4.0mm². For the 8-way DIN rail wire sizes allowable are 0.5mm² to 2.5mm²

Leads connected to the terminals shall be insulated for the appropriate voltage and this insulation shall extend to within 1mm of the metal of the terminal throat. They shall only be installed and wired with cable in an ambient temperature of -10°C to +80°C

All terminal screws, used or unused, shall be tightened down to between 0.5 Nm and 0.7 Nm.

| Voltage option | Max Voltage | Min resistor value allowable in module Type C unit (1.5W) |
|----------------|-------------|---|
| 6 V dc | 6 V dc | 27 ohms |
| 12V dc | 12 V dc | 110 ohms |
| 24V dc | 24 V dc | 430 ohms |
| 48V dc | 48 V dc | 1K8 ohms |

Table 1

7.1) Current Limitations

The maximum allowable current is determined as the smallest value from the following scenarios:

- When both module resistor values are the same as or above the minimum range of values shown in table 1, the current is not further limited. However, when either resistor value is lower than those shown in table 1, the current must be limited to the values given in table 2.

| Voltage option | Max Voltage | Max current when resistor values lower than minimum |
|----------------|-------------|---|
| 6 V dc | 6 V dc | 250mA |
| 12V dc | 12 V dc | 125mA |
| 24V dc | 24 V dc | 62mA |
| 48V dc | 48 V dc | 31mA |

Table 2

For example, if a 24V DC unit is fitted with a series resistor of 270 ohms, the maximum current of the unit would be reduced to 62mA since the resistance is less than the minimum 430 ohms allowable at this voltage.

E2S recommends a minimum resistor value of 100 ohms for a Series device and 180 ohms for an EOL device fitted to a 24V unit.

- If a diode module is pre-fitted as either an EOL or Series Device, the following current limitation applies:

| Unit Voltage | Max. Diode Current |
|----------------|--------------------|
| 48V DC | 0.75A |
| 6, 12 & 24V DC | 2.0A |

- If a Zener diode module is pre-fitted as either EOL or Series device, the following current limitation applies:

| Zener Voltage | Max. Input Voltage | Max. Current |
|---------------|--------------------|--------------|
| 3.3V | 56V DC | 230mA |
| 4.7V | | 162mA |
| 5.1V | | 149mA |
| 5.6V | | 136mA |
| 6.2V | | 122mA |
| 6.8V | | 112mA |
| 10V | | 76mA |

| | |
|-----|------|
| 12V | 63mA |
|-----|------|

- Units with LED code 'C'

GNExCP6C-PBXXXXXXXXXXC-XX-ExxxR-SxxxR

Maximum current is **reduced to 20mA**. In this case, the current-limiting resistor for the LED is not present, so that to safely power the LED the maximum current must be limited.

For units with LED code 'L', the current is limited by the LED current-limiting resistor. See value of this resistor in table below.

GNExCP6C-PBXXXXXXXXXXL-XX-ExxxR-SxxxR

| LED Resistor | Max. Input Voltage |
|-----------------|--------------------|
| 3K3 (3300 ohms) | 56V DC |
| 1K5 (1500 ohms) | 28V DC |

8) Testing unit operation

The push button unit can be tested without the need to replace any element.

To test, lift the cover lift flap to reveal the push button. The button should be pressed into the body to activate the unit and place it into the operated condition.

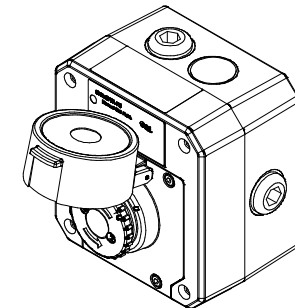

The call point switch will now change over its contacts to operate the alarm.

Once testing is complete the unit needs to be reset from the operated condition.

Rotate the push button anticlockwise by an angle of 55°, see guide alignment marks on the button and cover, shown below (1). The push button should pop back up to its original position.

Ensure that the push button has also twisted back clockwise by 55° to its original position see guide marks on button and cover, shown below (2). The unit is now reset

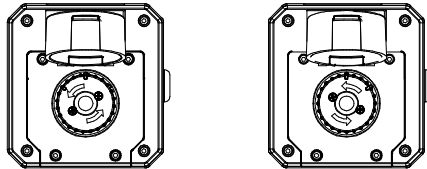
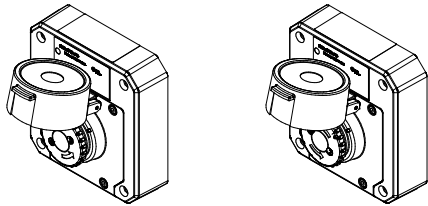

1. On operated unit twist push button anticlockwise 55° to reset

2. Button should pop up and twist back to original position

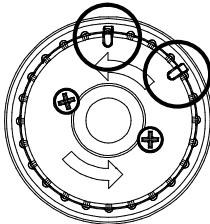

Note: use alignment marks circled to indicate the push buttons status/position

Unit currently shown as 'standby condition'

Resetting an operated unit is the same as resetting a tested unit.

9) SIL 2 Reliability Data

Reliability and Functional safety IEC/EN61508 which has been assessed and is considered suitable for use in low demand safety function:

- Random Hardware Failures and Systematic Failures (route 2H)
- As an unvoted item (i.e. hardware fault tolerance of 0) at SIL 2

The product was assessed against failure modes:

- Failure to close a contact when the call point is struck with specified force
- Failure to open a contact when the call point is struck with specified force
- Spurious output despite no input

| | |
|--|-----------------------|
| Integrity in respect of failure to close | SIL 2 |
| Total Failure rate | 0.133 pmh |
| "hazardous" failure rate (revealed) | 0 pmh |
| "hazardous" failure rate (unrevealed) | 0.1 pmh |
| "safe" failure rate (revealed) | 0.033 pmh |
| "safe" failure rate (unrevealed) | 0 |
| Diagnostic Coverage | 99% |
| System type | A |
| Hardware Fault Tolerance | 0 |
| Safe Failure Fraction | >99% |
| PFD (hazardous failure) | 1.25×10^{-3} |
| Proof Test Interval | Up to 1 year |

SINGLE MICROSWITCH | DEVICES

SHEET 1

PRODUCTS:
 GNExCP6B/C/D/E - BG
 GNExCP6B/C/D/E - PB
 GNExCP6B/C/D/E - PT

| Diagram | Sheet |
|--|---------|
| Dual Switch Wiring Configurations | 2,4,5,6 |
| LED Indicator Wiring Configurations | 3,4,6 |
| Parallel Dual Switch Wiring Configurations | 5, 6 |

GNEXCP6B-BG[s][t][l][e][m][d][v][o][x][u][v][e][s] Series
 Switch Type [s] Product Version [v] Product Option [o] LED Indicator [u]
 Terminals [t] EOL Module [e] Module [s]

| Module Device Codes | | |
|---------------------|-------|--------|
| | EOL | Series |
| Resistor | ExxxR | SxxxR |
| Diode | ED1 | SD1 |
| Zener Diode | ExxxZ | SxxxZ |
| LED | N/A | L or C |

| ISSUE | MOD No. | REASON - INITIAL - DATE |
|-------|---------|---|
| 2 | ACN0077 | TYPE E ADDED. DUAL VERSION SCHEMATICS UPDATED. SHEET 3 ADDED FOR LED DIAGRAMS. D.A.H - 28-08-2020 |
| 3 | | DEVICE POLARITY ADDED. CONFIG 8 AND 12 ADDED (LED ONLY) CODING UPDATE FOR CONFIG 3 AND 4 D.A.H - 21-02-2022 |
| 4 | | CONFIG 13 REMOVED, CONFIGS RE-NUMBERED 1 TO 24 D.A.H - 17-11-2022 |

| SINGLE SWITCH WITH EOL DEVICE | CONFIG. 1 | SINGLE SWITCH WITH SERIES DEVICE | CONFIG. 2 | SINGLE SWITCH WITH EOL & SERIES DEVICE | CONFIG. 3 | SINGLE SWITCH WITH EOL & SERIES DEVICE | CONFIG. 4 |
|-------------------------------|-----------|----------------------------------|-----------|--|-----------|--|-----------|
|-------------------------------|-----------|----------------------------------|-----------|--|-----------|--|-----------|

| | | | | | | | | | | | |
|---|-----------------------|----------------------------------|--|-----------------------|-------------------------------------|---|------------------------------|------------------------------------|--|------------------------------|--|
| SWITCH TYPE [s] PRODUCT OPTION [o] EOL MODULE [e] | [S] [1] [Exxxx] | Single Standard EOL Device | SWITCH TYPE [s] PRODUCT OPTION [o] SERIES MODULE [s] | [S] [1] [Sxxxx] | Single Standard Series Device | SWITCH TYPE [s] PRODUCT OPTION [o] MODULES [e][s] | [S] [1] [Exxxx][Sxxxx] | Single Standard EOL + Series | SWITCH TYPE [s] PRODUCT OPTION [o] MODULE [e][s] | [S] [W] [Exxxx][Sxxxx] | Single Alternative Wiring EOL + Series |
|---|-----------------------|----------------------------------|--|-----------------------|-------------------------------------|---|------------------------------|------------------------------------|--|------------------------------|--|

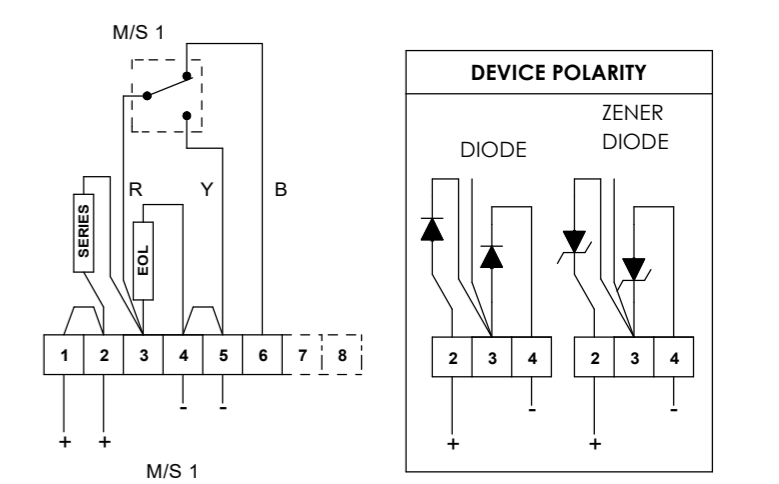
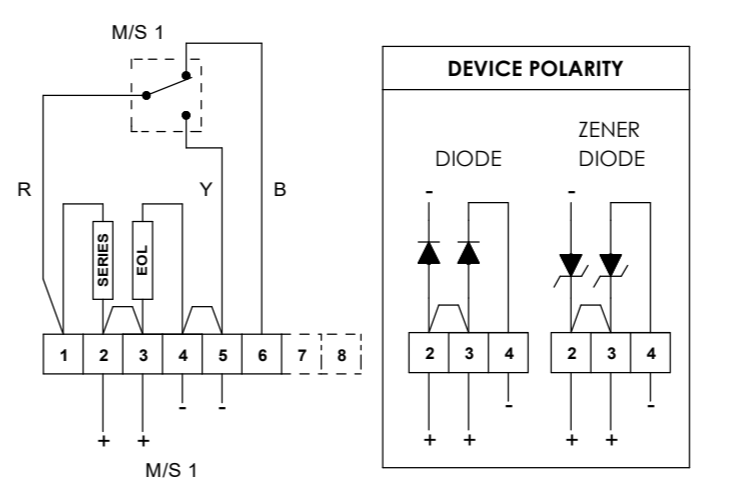
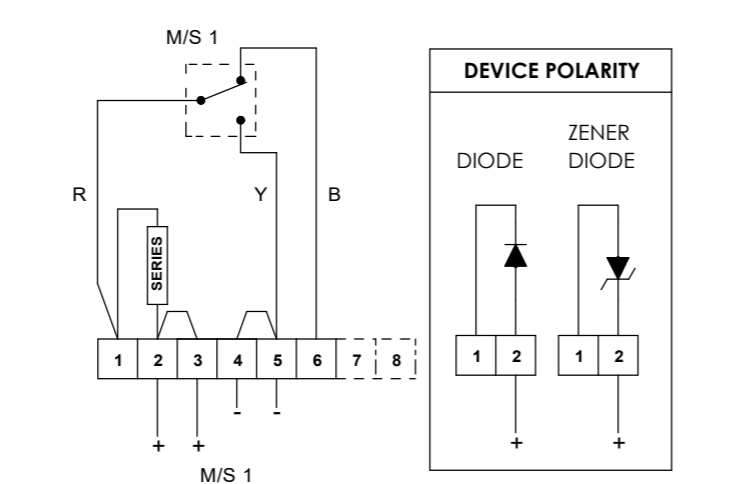
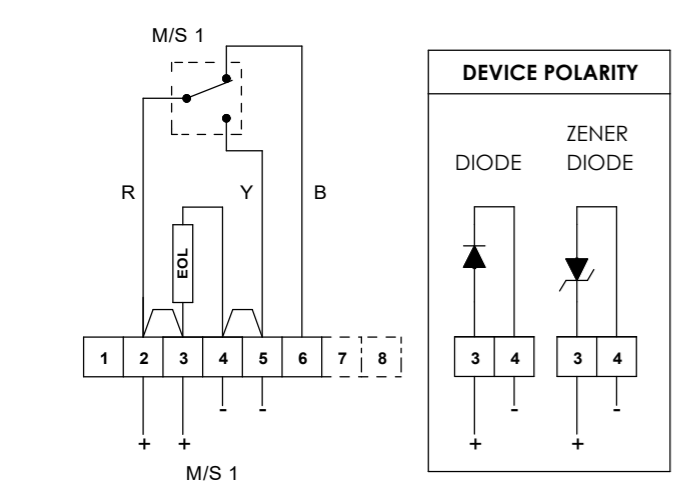
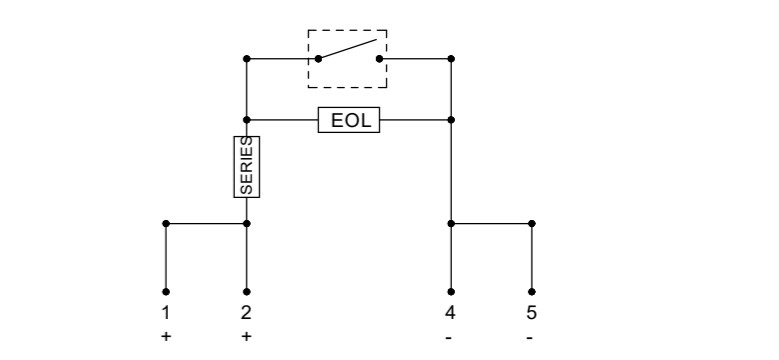
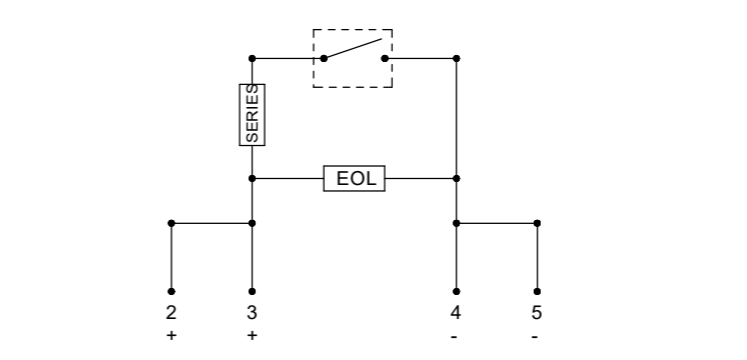
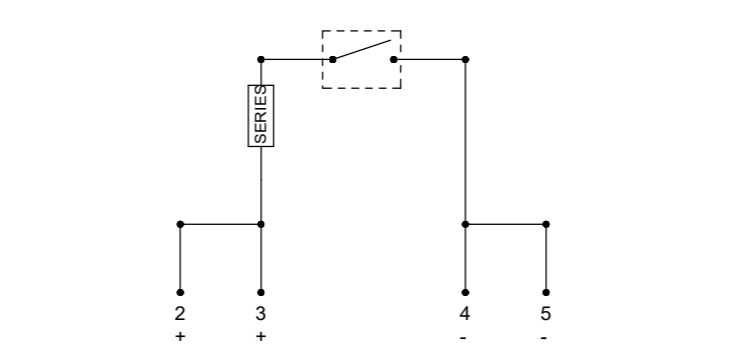
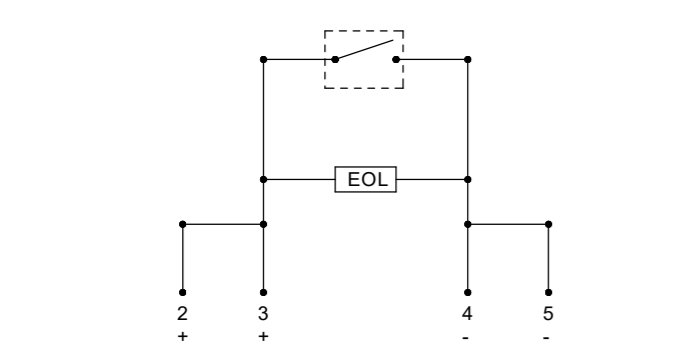

Circuit shown in Unoperated condition

**Unoperated condition
(Glass Intact / Standby Condition)**
 Terminals +(2,3) & -(4,5) open
 Terminals +(2,3) & (6) closed

**Operated condition
(Glass Broken / Button pushed in)**
 Terminals +(2,3) & -(4,5) closed
 Terminals +(2,3) & (6) open

Circuit shown in Unoperated condition

**Unoperated condition
(Glass Intact / Standby Condition)**
 Terminals +(2,3) & -(4,5) open
 Terminals +(2,3) & (6) closed

**Operated condition
(Glass Broken / Button pushed in)**
 Terminals +(2,3) & -(4,5) closed
 Terminals +(2,3) & (6) open

Circuit shown in Unoperated condition

**Unoperated condition
(Glass Intact / Standby Condition)**
 Terminals +(2,3) & -(4,5) open
 Terminals +(2,3) & (6) closed

**Operated condition
(Glass Broken / Button pushed in)**
 Terminals +(2,3) & -(4,5) closed
 Terminals +(2,3) & (6) open

Circuit shown in Unoperated condition

**Unoperated condition
(Glass Intact / Standby Condition)**
 Terminals +(1,2) & -(4,5) M/S 1 open
 Terminals +(1,2) & (6) M/S 1 closed

**Operated condition
(Glass Broken / Button pushed in)**
 Terminals +(1,2) & -(4,5) M/S 1 closed
 Terminals +(1,2) & (6) M/S 1 open

DRAWING TO BS8888:2000
 GEOMETRIC TOLERANCES TO ISO1101:1983
 LINEAR DIMENSIONAL TOLS
 ANGULAR DIMENSIONAL TOLS

STANDARDS
 GNExCP6B/C/D/E CALL POINTS

| DRAWN | DATE |
|-----------|----------|
| D.HOWGILL | 07-02-20 |
| CHECKED | DATE |
| R.N.POTTS | 07-02-20 |
| APPROVED | DATE |
| R.N.POTTS | 07-02-20 |

| SURFACE FINISH | WEIGHT (Kg) |
|----------------------|-------------|
| | |
| MATERIAL | |
| | |
| ALTERNATIVE MATERIAL | |
| | |

THIS DRAWING AND ANY INFORMATION OR DESCRIPTIVE MATTER THEREIN IS COMMUNICATED IN CONFIDENCE AND IS THE COPYRIGHT PROPERTY OF EUROPEAN SAFETY SYSTEMS LTD. NEITHER THE WHOLE OR ANY EXTRACT MAY BE DISCLOSED, LOANED, COPIED OR USED FOR MANUFACTURING OR TENDERING PURPOSES WITHOUT THEIR WRITTEN CONSENT.

© EUROPEAN SAFETY SYSTEMS LTD. AS PER LATEST DATE OF ISSUE SHOWN ABOVE

EUROPEAN SAFETY SYSTEMS LTD
 IMPRESS HOUSE
 MANSELL ROAD
 ACTON
 LONDON W3 7QH
 WWW.E2S.COM

| ALL DIMENSIONS IN MM IF IN DOUBT, ASK - DO NOT SCALE | | |
|---|--------|--------------------|
| | | A3 |
| TITLE | | |
| GNExCP6B/C/D/E-BG/PB/PT MANUAL CALL POINT WIRING SCHEMATIC | | |
| SCALE | SHEET | DRAWING NUMBER |
| NTS | 1 OF 6 | D154-06-051 |

DUAL MICROSWITCH | DEVICES

SHEET 2

Notes:
1. Other configurations of dual switch units are possible. Contact E2S sales to discuss options.

GNEXCP6B-BG[s][t][l][e][m][d][v][o][x][u][v][e][s] Series
 Switch Type [s] Terminals [t] Product Version [v] Product Option [o] LED Indicator [u] Module [s] EOL Module [e]

| Module Device Codes | | |
|---------------------|-------|--------|
| | EOL | Series |
| Resistor | ExxxR | SxxxR |
| Diode | ED1 | SD1 |
| Zener Diode | ExxxZ | SxxxZ |
| LED | N/A | L or C |

| ISSUE | MOD No. | REASON - INITIAL - DATE |
|-------|---------|--------------------------------|
| 2 | ACN0077 | SEE SHEET 1 D.A.H - 28-08-2020 |
| 3 | | SEE SHEET 1 D.A.H - 06-07-2021 |
| 4 | | SEE SHEET 1 D.A.H - 17-11-2022 |

| DUAL SWITCH WITH EOL DEVICE | CONFIG. 5 | DUAL SWITCH WITH SERIES DEVICES | CONFIG. 6 | DUAL SWITCH WITH EOL & SERIES DEVICE | CONFIG. 7 | DUAL SWITCH WITH EOL & SERIES DEVICE | CONFIG. 8 |
|---|--------------------------------|---|--|---|---|---|---|
| SWITCH TYPE [s] [D] PRODUCT OPTION [o] [1] EOL MODULE [e] [Exxxx] | Dual Standard EOL Device | SWITCH TYPE [s] [D] TERMINALS [t] [D] PRODUCT OPTION [o] [1] SERIES MODULE [s] [Sxxxx] | Dual DIN Rail Only Standard Series Device | SWITCH TYPE [s] [D] TERMINALS [t] [D] PRODUCT OPTION [o] [1] MODULES [e][s] [Exxxx][Sxxxx] | Dual DIN Rail Only Standard EOL + Series | SWITCH TYPE [s] [D] TERMINALS [t] [D] PRODUCT OPTION [o] [W] MODULES [e][s] [Exxxx][Sxxxx] | Dual DIN Rail Only Alternative Wiring EOL + Series |

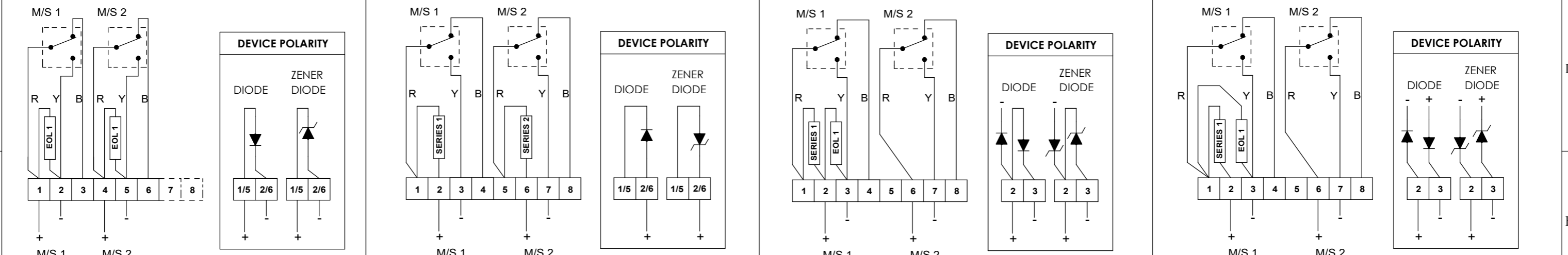
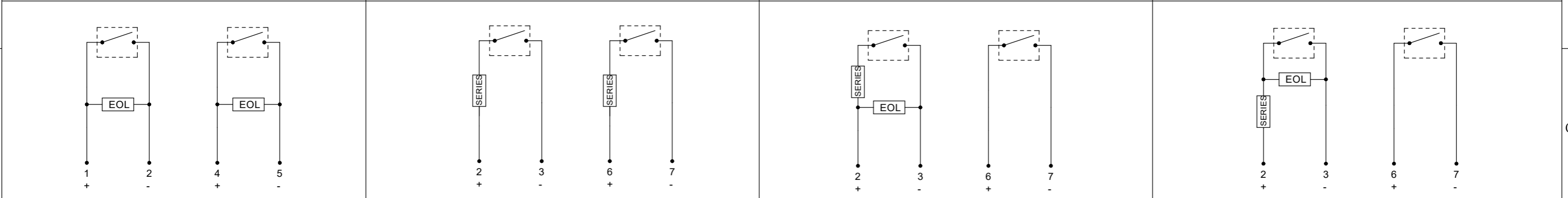

Circuit shown in Unoperated condition

Unoperated condition (Glass Intact / Standby Condition)
 Terminals + (1) & -(2) M/S 1 and +(4) & -(5) M/S 2 open
 Terminals +(1) & (3) M/S 1 and +(4) & (6) M/S 2 closed

Operated condition (Glass Broken / Button pushed in)
 Terminals + (1) & -(2) M/S 1 open and +(4) & -(5) M/S 2 closed
 Terminals +(1) & (3) M/S 1 and +(4) & (6) M/S 2 open

| | | | | | | | | | | |
|---|--|------------------------------|-------------------------|---|---|---|---|------------------------|--------------------------------------|-----------|
| DRAWING TO BS8888:2000 GEOMETRIC TOLERANCES TO ISO1101:1983 LINEAR DIMENSIONAL TOLS ANGULAR DIMENSIONAL TOLS | DRAWN D.HOWGILL | DATE 07-02-20 | SURFACE FINISH | WEIGHT (Kg) | THIS DRAWING AND ANY INFORMATION OR DESCRIPTIVE MATTER THEREIN IS COMMUNICATED IN CONFIDENCE AND IS THE COPYRIGHT PROPERTY OF EUROPEAN SAFETY SYSTEMS LTD. NEITHER THE WHOLE OR ANY EXTRACT MAY BE DISCLOSED, LOANED, COPIED OR USED FOR MANUFACTURING OR TENDERING PURPOSES WITHOUT THEIR WRITTEN CONSENT. | EUROPEAN SAFETY SYSTEMS LTD IMPRESS HOUSE MANSELL ROAD ACTON LONDON W3 7QH WWW.E2S.COM | ALL DIMENSIONS IN MM IF IN DOUBT, ASK - DO NOT SCALE | | | A3 |
| | CHECKED R.N.POTTS | DATE 07-02-20 | MATERIAL | TITLE GNExCP6B/C/D/E-BG/PB/PT MANUAL CALL POINT WIRING SCHEMATIC | | | | | | |
| | STANDARDS GNExCP6B/C/D/E CALL POINTS | APPROVED R.N.POTTS | DATE 07-02-20 | ALTERNATIVE MATERIAL | | | SCALE NTS | SHEET 2 OF 6 | DRAWING NUMBER D154-06-051 | |

SINGLE MICROSWITCH | LED | DEVICES

SHEET 3

Notes:
 1. LED available only on GNExCP6B and GNExCP6C Units
 2. GNExCP6C Units have the option to remove the LED current-limiting resistor RL1 using LED option 'C'. In all other cases, RL1 is included.

GNExCP6B-BG[s][t][l][e][m][d][v][o][x][u]-[v][e][s] Series
 Switch Type [s] Terminals [t] Product Version [v] Product Option [o] LED Indicator [u] EOL Module [e]

| Module Device Codes | | |
|---------------------|-------|--------|
| | EOL | Series |
| Resistor | ExxxR | SxxxR |
| Diode | ED1 | SD1 |
| Zener Diode | ExxxZ | SxxxZ |
| LED | N/A | L or C |

| ISSUE | MOD No. | REASON - INITIAL - DATE |
|-------|---------|--------------------------------|
| 2 | ACN0077 | SEE SHEET 1 D.A.H - 28-08-2020 |
| 3 | | SEE SHEET 1 D.A.H - 06-07-2021 |
| 4 | | SEE SHEET 1 D.A.H - 17-11-2022 |

| SINGLE SWITCH WITH LED ONLY | CONFIG. 9 | SINGLE SWITCH WITH LED & SERIES DEVICE | CONFIG. 10 | SINGLE SWITCH WITH LED & EOL DEVICE | CONFIG. 11 | SINGLE SWITCH WITH LED, EOL & SERIES DEVICE | CONFIG. 12 |
|-----------------------------|-----------|--|------------|-------------------------------------|------------|---|------------|
|-----------------------------|-----------|--|------------|-------------------------------------|------------|---|------------|

| | | | | | | | |
|--|---------------------------|---|--|--|---|---|--|
| SWITCH TYPE [s] [S] PRODUCT OPTION [o] [1] LED INDICATOR [u] [L] | Single Standard LED | SWITCH TYPE [s] [S] PRODUCT OPTION [o] [1] LED INDICATOR [u] [L] SERIES MODULE [s] [Sxxxx] | Single Standard LED Series Device | SWITCH TYPE [s] [S] PRODUCT OPTION [o] [1] LED INDICATOR [u] [L] EOL MODULE [e] [Exxxx] | Single Standard LED EOL Device | SWITCH TYPE [s] [S] PRODUCT OPTION [o] [1] LED INDICATOR [u] [L] MODULES [e][s] [Exxxx][Sxxxx] | Single Standard LED EOL + Series Device |
|--|---------------------------|---|--|--|---|---|--|

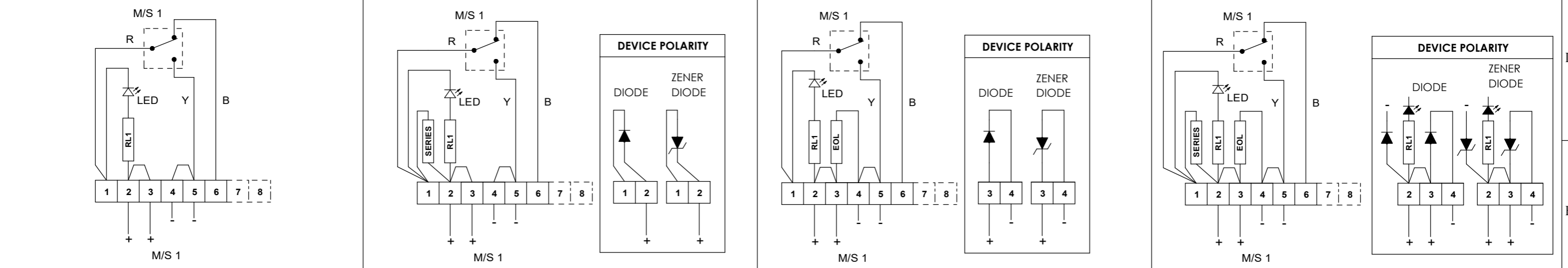
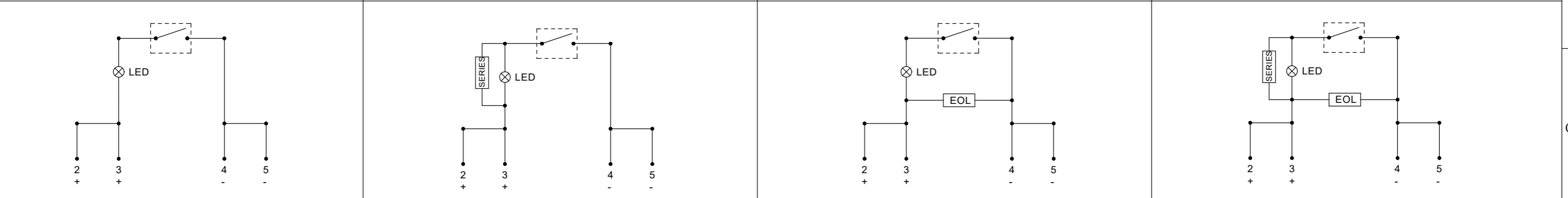

| | | | |
|--|--|--|--|
| <p>Circuit shown in Unoperated condition</p> <p>Unoperated condition (Glass Intact / Standby Condition) Terminals +(2,3) & -(4,5) open Terminals +(2,3) & (6) closed</p> <p>Operated condition (Glass Broken / Button pushed in) Terminals +(2,3) & -(4,5) closed Terminals +(2,3) & (6) open</p> | <p>Circuit shown in Unoperated condition</p> <p>Unoperated condition (Glass Intact / Standby Condition) Terminals +(2,3) & -(4,5) open Terminals +(2,3) & (6) closed</p> <p>Operated condition (Glass Broken / Button pushed in) Terminals +(2,3) & -(4,5) closed Terminals +(2,3) & (6) open</p> | <p>Circuit shown in Unoperated condition</p> <p>Unoperated condition (Glass Intact / Standby Condition) Terminals +(2,3) & -(4,5) open Terminals +(2,3) & (6) closed</p> <p>Operated condition (Glass Broken / Button pushed in) Terminals +(2,3) & -(4,5) closed Terminals +(2,3) & (6) open</p> | <p>Circuit shown in Unoperated condition</p> <p>Unoperated condition (Glass Intact / Standby Condition) Terminals +(2,3) & -(4,5) open Terminals +(2,3) & (6) closed</p> <p>Operated condition (Glass Broken / Button pushed in) Terminals +(2,3) & -(4,5) closed Terminals +(2,3) & (6) open</p> |
|--|--|--|--|

| | | | | | | | |
|---|---|----------------|----------------------|---|--|--|---|
| DRAWING TO BS8888:2000 GEOMETRIC TOLERANCES TO ISO1101:1983 LINEAR DIMENSIONAL TOLS ANGULAR DIMENSIONAL TOLS | DRAWN D.HOWGILL DATE 07-02-20 | SURFACE FINISH | WEIGHT (Kg) | THIS DRAWING AND ANY INFORMATION OR DESCRIPTIVE MATTER THEREIN IS COMMUNICATED IN CONFIDENCE AND IS THE COPYRIGHT PROPERTY OF EUROPEAN SAFETY SYSTEMS LTD. NEITHER THE WHOLE OR ANY EXTRACT MAY BE DISCLOSED, LOANED, COPIED OR USED FOR MANUFACTURING OR TENDERING PURPOSES WITHOUT THEIR WRITTEN CONSENT. | <p>EUROPEAN SAFETY SYSTEMS LTD IMPRESS HOUSE MANSELL ROAD ACTON LONDON W3 7QH WWW.E2S.COM</p> | ALL DIMENSIONS IN MM IF IN DOUBT, ASK - DO NOT SCALE | <p>A3</p> |
| STANDARDS GNExCP6B/C/D/E CALL POINTS | CHECKED R.N.POTTS DATE 07-02-20 | MATERIAL | ALTERNATIVE MATERIAL | <p>EUROPEAN SAFETY SYSTEMS LTD. AS PER LATEST DATE OF ISSUE SHOWN ABOVE</p> | <p>EUROPEAN SAFETY SYSTEMS LTD IMPRESS HOUSE MANSELL ROAD ACTON LONDON W3 7QH WWW.E2S.COM</p> | TITLE GNExCP6B/C/D/E-BG/PB/PT MANUAL CALL POINT WIRING SCHEMATIC | <p>SCALE NTS</p> <p>SHEET 3 OF 6</p> <p>DRAWING NUMBER D154-06-051</p> |

DUAL MICROSWITCH | LED | DEVICES

SHEET 4

Notes:
 1. LED available only on GNExCP6B and GNExCP6C Units
 2. GNExCP6C Units have the option to remove the LED current-limiting resistor RL1 using LED option 'C'. In all other cases, RL1 is included.

GNExCP6B-BG[s][t][l][e][m][d][v][o][x][u][v][e][s] Series
 Switch Type [s] Terminals [t] Product Version [v] Product Option [o] LED Indicator [u] EOL Module [e]

| Module Device Codes | | |
|---------------------|-------|--------|
| | EOL | Series |
| Resistor | ExxxR | SxxxR |
| Diode | ED1 | SD1 |
| Zener Diode | ExxxZ | SxxxZ |
| LED | N/A | L or C |

| ISSUE | MOD No. | REASON - INITIAL - DATE |
|-------|---------|--------------------------------|
| 2 | ACN0077 | SEE SHEET 1 D.A.H - 28-08-2020 |
| 3 | | SEE SHEET 1 D.A.H - 06-07-2021 |
| 4 | | SEE SHEET 1 D.A.H - 17-11-2022 |

| DUAL SWITCH WITH LED | CONFIG. 13 | DUAL SWITCH WITH LED & EOL DEVICE | CONFIG. 14 | DUAL SWITCH WITH LED & SERIES DEVICE | CONFIG. 15 | DUAL SWITCH WITH LED, EOL & SERIES DEVICE | CONFIG. 16 |
|----------------------|------------|-----------------------------------|------------|--------------------------------------|------------|---|------------|
|----------------------|------------|-----------------------------------|------------|--------------------------------------|------------|---|------------|

| | | | | | | | |
|--------------------|-------------------|--------------------|--------------------|--------------------|-----------------------|--------------------|----------------------------|
| SWITCH TYPE [s] | [D] Dual | SWITCH TYPE [s] | [D] Dual | SWITCH TYPE [s] | [D] Dual | SWITCH TYPE [s] | [D] Dual |
| TERMINALS [t] | [D] DIN Rail Only | TERMINALS [t] | [D] DIN Rail Only | TERMINALS [t] | [D] DIN Rail Only | TERMINALS [t] | [D] DIN Rail Only |
| PRODUCT OPTION [o] | [1] Standard | PRODUCT OPTION [o] | [1] Standard | PRODUCT OPTION [o] | [1] Standard | PRODUCT OPTION [o] | [1] Standard |
| LED INDICATOR [u] | [L] LED | LED INDICATOR [u] | [L] LED | LED INDICATOR [u] | [L] LED | LED INDICATOR [u] | [L] LED |
| | | EOL MODULE [e] | [ExxxR] EOL Device | SERIES MODULE [s] | [Sxxxx] Series Device | MODULES [e][s] | [Exxx][Sxxxx] EOL + Series |

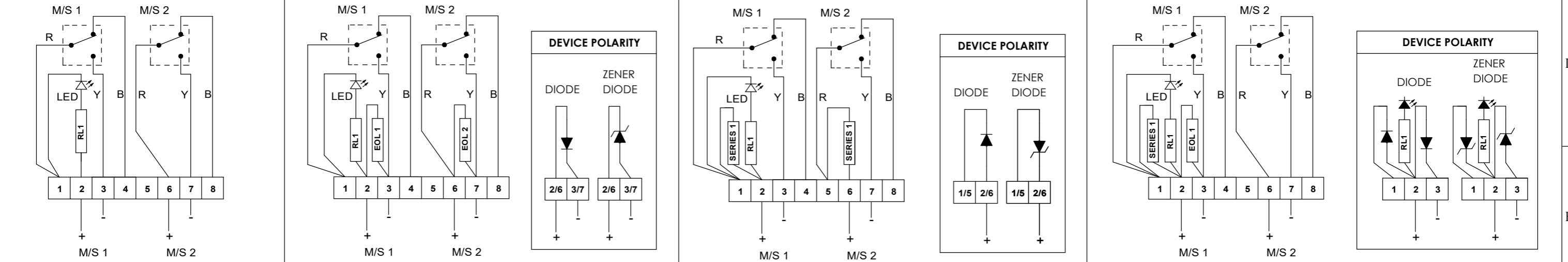
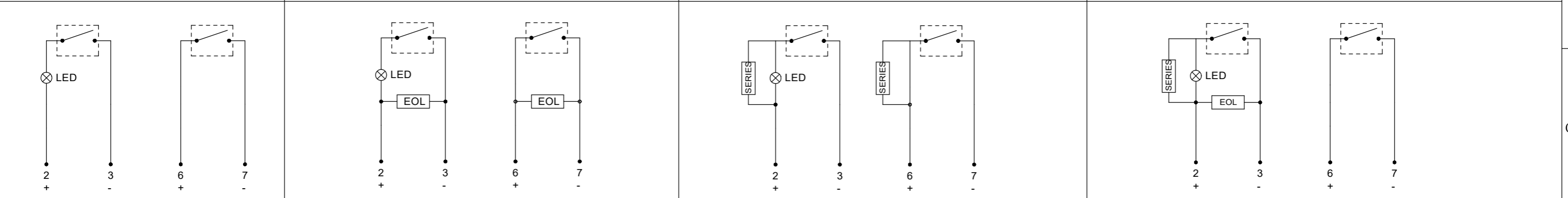

| | | | | | | | |
|---|--|---|--|---|--|---|--|
| Circuit shown in Unoperated condition | Unoperated condition (Glass Intact / Standby Condition) Terminals +(2) & -(3) M/S 1 and +(6) & -(7) M/S 2 open Terminals +(2) & (4) M/S 1 and +(6) & (8) M/S 2 closed | Circuit shown in Unoperated condition | Unoperated condition (Glass Intact / Standby Condition) Terminals +(2) & -(3) M/S 1 and +(6) & -(7) M/S 2 open Terminals +(2) & (4) M/S 1 and +(6) & (8) M/S 2 closed | Circuit shown in Unoperated condition | Unoperated condition (Glass Intact / Standby Condition) Terminals +(2) & -(3) M/S 1 and +(6) & -(7) M/S 2 open Terminals +(2) & (4) M/S 1 and +(6) & (8) M/S 2 closed | Circuit shown in Unoperated condition | Unoperated condition (Glass Intact / Standby Condition) Terminals +(2) & -(3) M/S 1 and +(6) & -(7) M/S 2 open Terminals +(2) & (4) M/S 1 and +(6) & (8) M/S 2 closed |
| Operated condition (Glass Broken / Button pushed in) Terminals +(2) & -(3) M/S 1 and +(6) & -(7) M/S 2 closed Terminals +(2) & (4) M/S 1 and +(6) & (8) M/S 2 open | Operated condition (Glass Broken / Button pushed in) Terminals +(2) & -(3) M/S 1 and +(6) & -(7) M/S 2 closed Terminals +(2) & (4) M/S 1 and +(6) & (8) M/S 2 open | Operated condition (Glass Broken / Button pushed in) Terminals +(2) & -(3) M/S 1 and +(6) & -(7) M/S 2 closed Terminals +(2) & (4) M/S 1 and +(6) & (8) M/S 2 open | Operated condition (Glass Broken / Button pushed in) Terminals +(2) & -(3) M/S 1 and +(6) & -(7) M/S 2 closed Terminals +(2) & (4) M/S 1 and +(6) & (8) M/S 2 open | Operated condition (Glass Broken / Button pushed in) Terminals +(2) & -(3) M/S 1 and +(6) & -(7) M/S 2 closed Terminals +(2) & (4) M/S 1 and +(6) & (8) M/S 2 open | Operated condition (Glass Broken / Button pushed in) Terminals +(2) & -(3) M/S 1 and +(6) & -(7) M/S 2 closed Terminals +(2) & (4) M/S 1 and +(6) & (8) M/S 2 open | Operated condition (Glass Broken / Button pushed in) Terminals +(2) & -(3) M/S 1 and +(6) & -(7) M/S 2 closed Terminals +(2) & (4) M/S 1 and +(6) & (8) M/S 2 open | Operated condition (Glass Broken / Button pushed in) Terminals +(2) & -(3) M/S 1 and +(6) & -(7) M/S 2 closed Terminals +(2) & (4) M/S 1 and +(6) & (8) M/S 2 open |

| | | | | | | | | |
|---|--|----------------|----------------------|---|---|---|-----------------|--------------------------------------|
| DRAWING TO BS8888:2000 GEOMETRIC TOLERANCES TO ISO1101:1983 LINEAR DIMENSIONAL TOLS ANGULAR DIMENSIONAL TOLS | DRAWN D.HOWGILL DATE 07-02-20 | SURFACE FINISH | WEIGHT (Kg) | THIS DRAWING AND ANY INFORMATION OR DESCRIPTIVE MATTER THEREIN IS COMMUNICATED IN CONFIDENCE AND IS THE COPYRIGHT PROPERTY OF EUROPEAN SAFETY SYSTEMS LTD. NEITHER THE WHOLE OR ANY EXTRACT MAY BE DISCLOSED, LOANED, COPIED OR USED FOR MANUFACTURING OR TENDERING PURPOSES WITHOUT THEIR WRITTEN CONSENT. | | ALL DIMENSIONS IN MM IF IN DOUBT, ASK - DO NOT SCALE | | A3 |
| STANDARDS GNExCP6B/C/D/E CALL POINTS | CHECKED R.N.POTTS DATE 07-02-20 | MATERIAL | ALTERNATIVE MATERIAL | EUROPEAN SAFETY SYSTEMS LTD. AS PER LATEST DATE OF ISSUE SHOWN ABOVE | EUROPEAN SAFETY SYSTEMS LTD IMPRESS HOUSE MANSELL ROAD ACTON LONDON W3 7QH WWW.E2S.COM | TITLE GNExCP6B/C/D/E-BG/PB/PT MANUAL CALL POINT WIRING SCHEMATIC | | |
| | APPROVED R.N.POTTS DATE 07-02-20 | | | © | | SCALE NTS | SHEET 4 OF 6 | DRAWING NUMBER D154-06-051 |

DUAL MICROSWITCHES IN PARALLEL

SHEET 5

Notes:
1. Other configurations of dual switch units are possible. Contact E2S sales to discuss options.

GNEXCP6B-BG[s][t][l][e][m][d][v][o][x][u][v][e][s] Series
 Switch Type [s] Terminals [t] Product Version [v] Product Option [o] LED Indicator [u] Module [s] EOL Module [e]

| Module Device Codes | | |
|---------------------|-------|--------|
| | EOL | Series |
| Resistor | ExxxR | SxxxR |
| Diode | ED1 | SD1 |
| Zener Diode | ExxxZ | SxxxZ |
| LED | N/A | L or C |

| ISSUE | MOD No. | REASON - INITIAL - DATE |
|-------|---------|--------------------------------|
| 2 | ACN0077 | SEE SHEET 1 D.A.H - 28-08-2020 |
| 3 | | SEE SHEET 1 D.A.H - 06-07-2021 |
| 4 | | SEE SHEET 1 D.A.H - 17-11-2022 |

| | | | | | | | |
|------------------------------------|-------------------|--|-------------------|---|-------------------|---|-------------------|
| DUAL SWITCH WITH EOL DEVICE | CONFIG. 17 | DUAL SWITCH WITH SERIES DEVICES | CONFIG. 18 | DUAL SWITCH WITH EOL & SERIES DEVICE | CONFIG. 19 | DUAL SWITCH WITH EOL & SERIES DEVICE | CONFIG. 20 |
|------------------------------------|-------------------|--|-------------------|---|-------------------|---|-------------------|

| | | | | | | | |
|---|--|---|--|---|--|---|--|
| SWITCH TYPE [s] [D] Dual PRODUCT OPTION [o] [P] Parallel Wiring EOL MODULE [e] [Exxxx] EOL Device | | SWITCH TYPE [s] [D] Dual PRODUCT OPTION [o] [P] Parallel Wiring SERIES MODULE [s] [Sxxxx] Series Device | | SWITCH TYPE [s] [D] Dual PRODUCT OPTION [o] [P] Parallel Wiring MODULE [e][s] [Exxxx][Sxxxx] EOL + Series | | SWITCH TYPE [s] [D] Dual TERMINALS [t] [D] DIN Rail Only PRODUCT OPTION [o] [V] Alternative Parallel Switch Wiring MODULE [e][s] [Exxxx][Sxxxx] EOL + Series | |
|---|--|---|--|---|--|---|--|

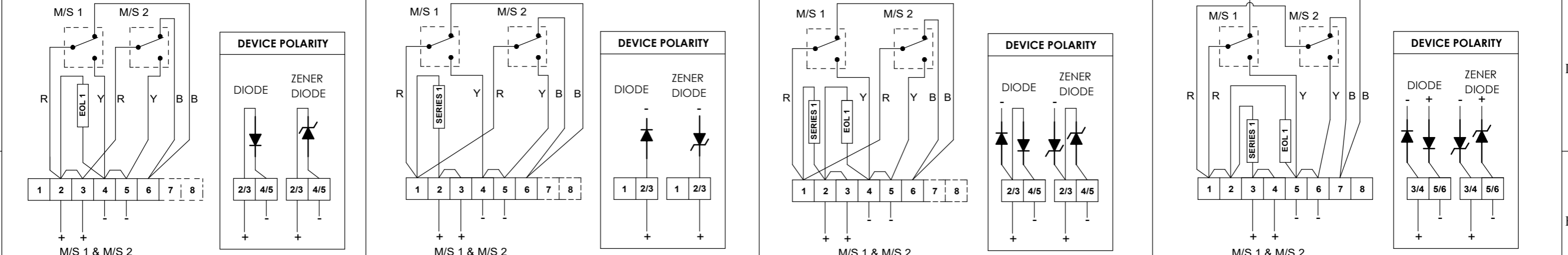
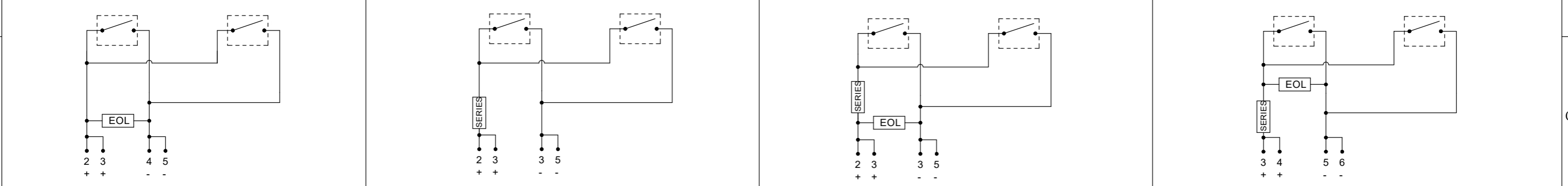

| | | | |
|--|--|--|--|
| <p>Circuit shown in Unoperated condition</p> <p>Unoperated condition (Glass Intact / Standby Condition) Terminals +(2,3) & -(4,5) M/S 1 & M/S 2 open Terminals +(2,3) & (6) M/S 1 & M/S 2 closed</p> <p>Operated condition (Glass Broken / Button pushed in) Terminals +(2,3) & -(4,5) M/S 1 & M/S 2 closed Terminals +(2,3) & (6) M/S 1 & M/S 2 open</p> | <p>Circuit shown in Unoperated condition</p> <p>Unoperated condition (Glass Intact / Standby Condition) Terminals +(2,3) & -(4,5) M/S 1 & M/S 2 open Terminals +(2,3) & (6) M/S 1 & M/S 2 closed</p> <p>Operated condition (Glass Broken / Button pushed in) Terminals +(2,3) & -(4,5) M/S 1 & M/S 2 closed Terminals +(2,3) & (6) M/S 1 & M/S 2 open</p> | <p>Circuit shown in Unoperated condition</p> <p>Unoperated condition (Glass Intact / Standby Condition) Terminals +(2,3) & -(4,5) M/S 1 & M/S 2 open Terminals +(2,3) & (6) M/S 1 & M/S 2 closed</p> <p>Operated condition (Glass Broken / Button pushed in) Terminals +(2,3) & -(4,5) M/S 1 & M/S 2 closed Terminals +(2,3) & (6) M/S 1 & M/S 2 open</p> | <p>Circuit shown in Unoperated condition</p> <p>Unoperated condition (Glass Intact / Standby Condition) Terminals +(3,4) & -(5,6) M/S 1 & M/S 2 open Terminals +(3,4) & (7) M/S 1 & M/S 2 closed</p> <p>Operated condition (Glass Broken / Button pushed in) Terminals +(3,4) & -(5,6) M/S 1 & M/S 2 closed Terminals +(3,4) & (7) M/S 1 & M/S 2 open</p> |
|--|--|--|--|

| | | | | | | | | | |
|---|-----------------------------|-------------------------|----------------|----------------------|---|---|---|------------------------|--------------------------------------|
| DRAWING TO BS8888:2000 GEOMETRIC TOLERANCES TO ISO1101:1983 LINEAR DIMENSIONAL TOLS ANGULAR DIMENSIONAL TOLS | DRAWN D.HOWGILL | DATE 07-02-20 | SURFACE FINISH | WEIGHT (Kg) | THIS DRAWING AND ANY INFORMATION OR DESCRIPTIVE MATTER THEREIN IS COMMUNICATED IN CONFIDENCE AND IS THE COPYRIGHT PROPERTY OF EUROPEAN SAFETY SYSTEMS LTD. NEITHER THE WHOLE OR ANY EXTRACT MAY BE DISCLOSED, LOANED, COPIED OR USED FOR MANUFACTURING OR TENDERING PURPOSES WITHOUT THEIR WRITTEN CONSENT. | EUROPEAN SAFETY SYSTEMS LTD IMPRESS HOUSE MANSELL ROAD ACTON LONDON W3 7QH WWW.E2S.COM | ALL DIMENSIONS IN MM IF IN DOUBT, ASK - DO NOT SCALE | | A3 |
| STANDARDS GNEXCP6B/C/D/E CALL POINTS | CHECKED R.N.POTTS | DATE 07-02-20 | MATERIAL | ALTERNATIVE MATERIAL | EUROPEAN SAFETY SYSTEMS LTD. AS PER LATEST DATE OF ISSUE SHOWN ABOVE | TITLE GNEXCP6B/C/D/E-BG/PB/PT MANUAL CALL POINT WIRING SCHEMATIC | SCALE NTS | SHEET 5 OF 6 | DRAWING NUMBER D154-06-051 |

DUAL MICROSWITCHES IN PARALLEL | LED

SHEET 6

Notes:
 1. LED available only on GNExCP6B and GNExCP6C Units
 2. GNExCP6C Units have the option to remove the LED current-limiting resistor RL1 using LED option 'C'. In all other cases, RL1 is included.

GNExCP6B-BG[s][t][l][e][m][d][v][o][x][u][v][e][s] Series
 Switch Type [s] Product Version [v] Product Option [o] LED Indicator [u]
 Terminals [t] EOL Module [e]

| Module Device Codes | | |
|---------------------|-------|--------|
| | EOL | Series |
| Resistor | ExxxR | SxxxR |
| Diode | ED1 | SD1 |
| Zener Diode | ExxxZ | SxxxZ |
| LED | N/A | L or C |

| ISSUE | MOD No. | REASON - INITIAL - DATE |
|-------|---------|--------------------------------|
| 2 | ACN0077 | SEE SHEET 1 D.A.H - 28-08-2020 |
| 3 | | SEE SHEET 1 D.A.H - 06-07-2021 |
| 4 | | SEE SHEET 1 D.A.H - 17-11-2022 |

| DUAL SWITCH WITH LED | CONFIG. 21 | DUAL SWITCH WITH EOL DEVICE | CONFIG. 22 | DUAL SWITCH WITH SERIES DEVICE | CONFIG. 23 | DUAL SWITCH WITH EOL & SERIES DEVICE | CONFIG. 24 |
|----------------------|------------|-----------------------------|------------|--------------------------------|------------|--------------------------------------|------------|
|----------------------|------------|-----------------------------|------------|--------------------------------|------------|--------------------------------------|------------|

| | | | | | | | |
|--|---|--|--|--|---|--|---|
| SWITCH TYPE [s] PRODUCT OPTION [o] LED INDICATOR [u] | [D] [P] [L] Dual Parallel Wiring LED | SWITCH TYPE [s] PRODUCT OPTION [o] LED INDICATOR [u] EOL MODULE [e] | [D] [P] [L] [Exxxx] Dual Parallel Wiring LED EOL Device | SWITCH TYPE [s] TERMINALS [t] PRODUCT OPTION [o] LED INDICATOR [u] SERIES MODULE [s] | [D] [D] [P] [L] [Sxxxx] Dual DIN Rail Only Parallel Wiring LED Series Device | SWITCH TYPE [s] TERMINALS [t] PRODUCT OPTION [o] LED INDICATOR [u] MODULE [e][s] | [D] [D] [P] [L] [Exxxx][Sxxxx] Dual DIN Rail Only Parallel Wiring LED EOL + Series |
|--|---|--|--|--|---|--|---|

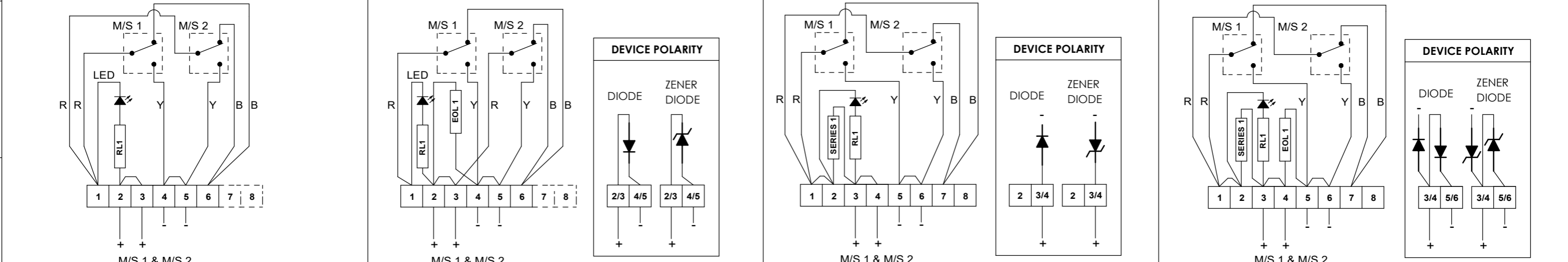
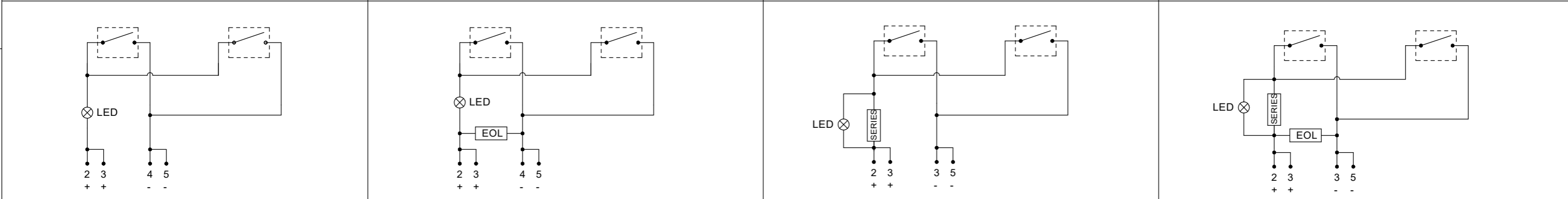

| | | | |
|--|--|--|--|
| <p>Circuit shown in Unoperated condition</p> <p>Unoperated condition (Glass Intact / Standby Condition) Terminals + (2,3) & -(4,5) M/S 1 & M/S 2 open Terminals + (2,3) & (6) M/S 1 & M/S 2 closed</p> <p>Operated condition (Glass Broken / Button pushed in) Terminals + (2,3) & -(4,5) M/S 1 & M/S 2 closed Terminals + (2,3) & (6) M/S 1 & M/S 2 open</p> | <p>Circuit shown in Unoperated condition</p> <p>Unoperated condition (Glass Intact / Standby Condition) Terminals + (2,3) & -(4,5) M/S 1 & M/S 2 open Terminals + (2,3) & (6) M/S 1 & M/S 2 closed</p> <p>Operated condition (Glass Broken / Button pushed in) Terminals + (2,3) & -(4,5) M/S 1 & M/S 2 closed Terminals + (2,3) & (6) M/S 1 & M/S 2 open</p> | <p>Circuit shown in Unoperated condition</p> <p>Unoperated condition (Glass Intact / Standby Condition) Terminals + (3,4) & -(5,6) M/S 1 & M/S 2 open Terminals + (3,4) & (7) M/S 1 & M/S 2 closed</p> <p>Operated condition (Glass Broken / Button pushed in) Terminals + (3,4) & -(5,6) M/S 1 & M/S 2 closed Terminals + (3,4) & (7) M/S 1 & M/S 2 open</p> | <p>Circuit shown in Unoperated condition</p> <p>Unoperated condition (Glass Intact / Standby Condition) Terminals + (3,4) & -(5,6) M/S 1 & M/S 2 open Terminals + (3,4) & (7) M/S 1 & M/S 2 closed</p> <p>Operated condition (Glass Broken / Button pushed in) Terminals + (3,4) & -(5,6) M/S 1 & M/S 2 closed Terminals + (3,4) & (7) M/S 1 & M/S 2 open</p> |
|--|--|--|--|

| | | | | | | | | | |
|---|--|------------------------------|-------------------------|---|--|---|---|------------------------|--------------------------------------|
| DRAWING TO BS8888:2000 GEOMETRIC TOLERANCES TO ISO1101:1983 LINEAR DIMENSIONAL TOLS ANGULAR DIMENSIONAL TOLS | DRAWN D.HOWGILL | DATE 07-02-20 | SURFACE FINISH | WEIGHT (Kg) | THIS DRAWING AND ANY INFORMATION OR DESCRIPTIVE MATTER THEREIN IS COMMUNICATED IN CONFIDENCE AND IS THE COPYRIGHT PROPERTY OF EUROPEAN SAFETY SYSTEMS LTD. NEITHER THE WHOLE OR ANY EXTRACT MAY BE DISCLOSED, LOANED, COPIED OR USED FOR MANUFACTURING OR TENDERING PURPOSES WITHOUT THEIR WRITTEN CONSENT. EUROPEAN SAFETY SYSTEMS LTD. AS PER LATEST DATE OF ISSUE SHOWN ABOVE | EUROPEAN SAFETY SYSTEMS LTD IMPRESS HOUSE MANSELL ROAD ACTON LONDON W3 7QH WWW.E2S.COM | ALL DIMENSIONS IN MM IF IN DOUBT, ASK - DO NOT SCALE | | A3 |
| | CHECKED R.N.POTTS | DATE 07-02-20 | MATERIAL | TITLE GNExCP6B/C/D/E-BG/PB/PT MANUAL CALL POINT WIRING SCHEMATIC | | | | | |
| | STANDARDS GNExCP6B/C/D/E CALL POINTS | APPROVED R.N.POTTS | DATE 07-02-20 | ALTERNATIVE MATERIAL | | | SCALE NTS | SHEET 6 OF 6 | DRAWING NUMBER D154-06-051 |

EU Declaration of Conformity



Manufacturer: European Safety Systems Ltd.
Impress House, Mansell Road, Acton
London, W3 7QH
United Kingdom

Authorised Representative: E2S Warnsignaltechnik UG
Charlottenstrasse 45-51
72764 Reutlingen
Germany

Equipment Type: GNExCP6A-BG, GNExCP6A-PB, GNExCP6A-PT
GNExCP6B-BG, GNExCP6B-PB, GNExCP6B-PT,
GNExCP6C-BG, GNExCP6C-PB, GNExCP6C-PT
GNExCP6D-BG, GNExCP6D-PB, GNExCP6D-PT
GNExCP6E-BG, GNExCP6E-PB, GNExCP6E-PT

Directive 2014/34/EU: Equipment and Protective Systems for use in Potentially Explosive Atmospheres (ATEX)

| | | | | | | | | | | | |
|---|---|-----------|---|-----------|--|-----------|--|-----------|--|-----------|--|
| Notified Body for EU type Examination (Module B): | Sira Certification Service Notified Body No.: 2813 CSA Group Netherlands B.V, Utrechtseweg 310, 6812 AR, Arnhem, Netherlands | | | | | | | | | | |
| EU-type Examination Certificate (Module B): | Sira 09ATEX3286X | | | | | | | | | | |
| Notified Body for Quality Assurance Notification / Conformity to EU-type based on quality assurance of the production process (Module D): | Sira Certification Service Notified Body No.: 2813 CSA Group Netherlands B.V, Utrechtseweg 310, 6812 AR, Arnhem, Netherlands | | | | | | | | | | |
| Quality Assurance Notification (Module D): | SIRA 05 ATEX M342 | | | | | | | | | | |
| Provisions fulfilled by the equipment: | <table><tr><td>GNExCP6A:</td><td>II 2G Ex db eb IIC T6 Gb (-40°C ≤ Ta ≤ +70°C) II 2D Ex tb IIIC T75°C Db (-40°C ≤ Ta ≤ +70°C) or</td></tr><tr><td>GNExCP6B:</td><td>II 2G Ex db eb mb IIC T4 Gb (-40°C ≤ Ta ≤ +50°C) II 2D Ex tb IIIC T80°C Db (-40°C ≤ Ta ≤ +50°C) or</td></tr><tr><td>GNExCP6C:</td><td>II 2G Ex db eb mb IIC T4 Gb (-40°C ≤ Ta ≤ +65°C) II 2D Ex tb IIIC T75°C Db (-40°C ≤ Ta ≤ +65°C) or</td></tr><tr><td>GNExCP6D:</td><td>II 2G Ex db eb mb IIC T4 Gb (-40°C ≤ Ta ≤ +70°C) II 2D Ex tb IIIC T80°C Db (-40°C ≤ Ta ≤ +70°C) or</td></tr><tr><td>GNExCP6E:</td><td>II 2G Ex db eb mb IIC T4 Gb (-40°C ≤ Ta ≤ +65°C) II 2D Ex tb IIIC T75°C Db (-40°C ≤ Ta ≤ +65°C)</td></tr></table> | GNExCP6A: | II 2G Ex db eb IIC T6 Gb (-40°C ≤ Ta ≤ +70°C) II 2D Ex tb IIIC T75°C Db (-40°C ≤ Ta ≤ +70°C) or | GNExCP6B: | II 2G Ex db eb mb IIC T4 Gb (-40°C ≤ Ta ≤ +50°C) II 2D Ex tb IIIC T80°C Db (-40°C ≤ Ta ≤ +50°C) or | GNExCP6C: | II 2G Ex db eb mb IIC T4 Gb (-40°C ≤ Ta ≤ +65°C) II 2D Ex tb IIIC T75°C Db (-40°C ≤ Ta ≤ +65°C) or | GNExCP6D: | II 2G Ex db eb mb IIC T4 Gb (-40°C ≤ Ta ≤ +70°C) II 2D Ex tb IIIC T80°C Db (-40°C ≤ Ta ≤ +70°C) or | GNExCP6E: | II 2G Ex db eb mb IIC T4 Gb (-40°C ≤ Ta ≤ +65°C) II 2D Ex tb IIIC T75°C Db (-40°C ≤ Ta ≤ +65°C) |
| GNExCP6A: | II 2G Ex db eb IIC T6 Gb (-40°C ≤ Ta ≤ +70°C) II 2D Ex tb IIIC T75°C Db (-40°C ≤ Ta ≤ +70°C) or | | | | | | | | | | |
| GNExCP6B: | II 2G Ex db eb mb IIC T4 Gb (-40°C ≤ Ta ≤ +50°C) II 2D Ex tb IIIC T80°C Db (-40°C ≤ Ta ≤ +50°C) or | | | | | | | | | | |
| GNExCP6C: | II 2G Ex db eb mb IIC T4 Gb (-40°C ≤ Ta ≤ +65°C) II 2D Ex tb IIIC T75°C Db (-40°C ≤ Ta ≤ +65°C) or | | | | | | | | | | |
| GNExCP6D: | II 2G Ex db eb mb IIC T4 Gb (-40°C ≤ Ta ≤ +70°C) II 2D Ex tb IIIC T80°C Db (-40°C ≤ Ta ≤ +70°C) or | | | | | | | | | | |
| GNExCP6E: | II 2G Ex db eb mb IIC T4 Gb (-40°C ≤ Ta ≤ +65°C) II 2D Ex tb IIIC T75°C Db (-40°C ≤ Ta ≤ +65°C) | | | | | | | | | | |
| Standards applied: | EN IEC 60079-0:2018 EN 60079-1:2014 EN 60079-7:2015/A1:2108 IEC 60079-18:2015/AC:2018 EN 60079-31: 2014 IP6X Dust Protection to EN60079-0 / EN 60079-31 | | | | | | | | | | |

Directive 2014/30/EU: Electromagnetic Compatibility Directive (EMC)

| | |
|--------------------|--|
| Standards applied: | EN 61000-6-1:2007 EN 61000-6-2:2005 EN 61000-6-3:2007 / A1:2011 / AC: 2012 EN 61000-6-4:2007 / A1: 2011 |
|--------------------|--|

EU Declaration of Conformity



Directive 2011/65/EU: Restriction of the use of certain hazardous substances in electrical and electronic equipment (RoHS)

The product and all the components contained within it are in accordance with the restriction of the use of hazardous substances in electrical and electronic equipment, including amendment by Directive 2015/863/EU.

Regulation (EC) 1907/2006: Registration, Evaluation, Authorisation and Restriction of Chemicals (REACH)

The product and all the components contained within it are free from substances of very high concern.

Other Standards and Regulations

EN 60529:1992+A2:2013 - Degrees of protection provided by enclosures (IP code) – enclosure rated IP66

On behalf of European Safety Systems Ltd., I declare that, on the date the equipment accompanied by this declaration is placed on the market, the equipment conforms with all technical and regulatory requirements of the above listed directives, regulations and standards.

This Declaration is issued under the sole responsibility of the manufacturer.

A handwritten signature in black ink, appearing to read 'Martin Streetz', written over a faint, illegible printed name.

Martin Streetz
Quality Assurance Manager

Document No.: DC-043_Issue_J
Date and Place of Issue: London, 23/12/2020

Manufacturer: European Safety Systems Ltd.
 Impress House, Mansell Road, Acton
 London, W3 7QH
 United Kingdom

Equipment Type: GNExCP6A-BG, GNExCP6A-PB, GNExCP6A-PT
 GNExCP6B-BG, GNExCP6B-PB, GNExCP6B-PT,
 GNExCP6C-BG, GNExCP6C-PB, GNExCP6C-PT
 GNExCP6D-BG, GNExCP6D-PB, GNExCP6D-PT
 GNExCP6E-BG, GNExCP6E-PB, GNExCP6E-PT

Directive UKSI 2016:1107 (as amended by UKSI 2019:696) – Schedule 3A, Part 1 : Product or Protective System Intended for use in Potentially Explosive Atmospheres (UKCA)

| | | | | | | | | | | | |
|---|---|-----------|---|-----------|--|-----------|--|-----------|--|-----------|--|
| Notified Body for UK type Examination (Module B): | Sira Certification Service Notified Body No.: 0518 Rake Lane, Eccleston, Chester CH4 9JN, UK | | | | | | | | | | |
| UK-type Examination Certificate (Module B): | CSAE 21UKEX3556X | | | | | | | | | | |
| Notified Body for Quality Assurance Notification / Conformity to EU-type based on quality assurance of the production process (Module D): | Sira Certification Service Notified Body No.: 0518 Rake Lane, Eccleston, Chester CH4 9JN, UK | | | | | | | | | | |
| Quality Assurance Notification (Module D): | CSAE 22UKQAN0046 | | | | | | | | | | |
| Provisions fulfilled by the equipment: | <table border="0"> <tr> <td>GNExCP6A:</td> <td>II 2G Ex db eb IIC T6 Gb (-40°C ≤ Ta ≤ +70°C) II 2D Ex tb IIIC T75°C Db (-40°C ≤ Ta ≤ +70°C) or</td> </tr> <tr> <td>GNExCP6B:</td> <td>II 2G Ex db eb mb IIC T4 Gb (-40°C ≤ Ta ≤ +50°C) II 2D Ex tb IIIC T80°C Db (-40°C ≤ Ta ≤ +50°C) or</td> </tr> <tr> <td>GNExCP6C:</td> <td>II 2G Ex db eb mb IIC T4 Gb (-40°C ≤ Ta ≤ +65°C) II 2D Ex tb IIIC T75°C Db (-40°C ≤ Ta ≤ +65°C) or</td> </tr> <tr> <td>GNExCP6D:</td> <td>II 2G Ex db eb mb IIC T4 Gb (-40°C ≤ Ta ≤ +70°C) II 2D Ex tb IIIC T80°C Db (-40°C ≤ Ta ≤ +70°C) or</td> </tr> <tr> <td>GNExCP6E:</td> <td>II 2G Ex db eb mb IIC T4 Gb (-40°C ≤ Ta ≤ +65°C) II 2D Ex tb IIIC T75°C Db (-40°C ≤ Ta ≤ +65°C)</td> </tr> </table> | GNExCP6A: | II 2G Ex db eb IIC T6 Gb (-40°C ≤ Ta ≤ +70°C) II 2D Ex tb IIIC T75°C Db (-40°C ≤ Ta ≤ +70°C) or | GNExCP6B: | II 2G Ex db eb mb IIC T4 Gb (-40°C ≤ Ta ≤ +50°C) II 2D Ex tb IIIC T80°C Db (-40°C ≤ Ta ≤ +50°C) or | GNExCP6C: | II 2G Ex db eb mb IIC T4 Gb (-40°C ≤ Ta ≤ +65°C) II 2D Ex tb IIIC T75°C Db (-40°C ≤ Ta ≤ +65°C) or | GNExCP6D: | II 2G Ex db eb mb IIC T4 Gb (-40°C ≤ Ta ≤ +70°C) II 2D Ex tb IIIC T80°C Db (-40°C ≤ Ta ≤ +70°C) or | GNExCP6E: | II 2G Ex db eb mb IIC T4 Gb (-40°C ≤ Ta ≤ +65°C) II 2D Ex tb IIIC T75°C Db (-40°C ≤ Ta ≤ +65°C) |
| GNExCP6A: | II 2G Ex db eb IIC T6 Gb (-40°C ≤ Ta ≤ +70°C) II 2D Ex tb IIIC T75°C Db (-40°C ≤ Ta ≤ +70°C) or | | | | | | | | | | |
| GNExCP6B: | II 2G Ex db eb mb IIC T4 Gb (-40°C ≤ Ta ≤ +50°C) II 2D Ex tb IIIC T80°C Db (-40°C ≤ Ta ≤ +50°C) or | | | | | | | | | | |
| GNExCP6C: | II 2G Ex db eb mb IIC T4 Gb (-40°C ≤ Ta ≤ +65°C) II 2D Ex tb IIIC T75°C Db (-40°C ≤ Ta ≤ +65°C) or | | | | | | | | | | |
| GNExCP6D: | II 2G Ex db eb mb IIC T4 Gb (-40°C ≤ Ta ≤ +70°C) II 2D Ex tb IIIC T80°C Db (-40°C ≤ Ta ≤ +70°C) or | | | | | | | | | | |
| GNExCP6E: | II 2G Ex db eb mb IIC T4 Gb (-40°C ≤ Ta ≤ +65°C) II 2D Ex tb IIIC T75°C Db (-40°C ≤ Ta ≤ +65°C) | | | | | | | | | | |
| Standards applied: | EN IEC 60079-0:2018 EN 60079-1:2014 EN 60079-7:2015/A1:2108 IEC 60079-18:2015/AC:2018 EN 60079-31: 2014 IP6X Dust Protection to EN60079-0 / EN 60079-31 | | | | | | | | | | |

Directive 2014/30/EU: Electromagnetic Compatibility Directive (EMC)

| | |
|--------------------|--|
| Standards applied: | EN 61000-6-1:2007 EN 61000-6-2:2005 EN 61000-6-3:2007 / A1:2011 / AC: 2012 EN 61000-6-4:2007 / A1: 2011 |
|--------------------|--|

Directive 2011/65/EU: Restriction of the use of certain hazardous substances in electrical and electronic equipment (RoHS)

The product and all the components contained within it are in accordance with the restriction of the use of hazardous substances in electrical and electronic equipment, including amendment by Directive 2015/863/EU.

Regulation (EC) 1907/2006: Registration, Evaluation, Authorisation and Restriction of Chemicals (REACH)

The product and all the components contained within it are free from substances of very high concern.



UKCA Declaration of Conformity



Other Standards and Regulations

EN 60529:1992+A2:2013 - Degrees of protection provided by enclosures (IP code) – enclosure rated IP66

On behalf of European Safety Systems Ltd., I declare that, on the date the equipment accompanied by this declaration is placed on the market, the equipment conforms with all technical and regulatory requirements of the above listed directives, regulations and standards.

This Declaration is issued under the sole responsibility of the manufacturer.

Martin Streetz
Quality Assurance Manager

Document No.: DC-094_Issue_A
Date and Place of Issue: London, 04/02/2022