

## 1) Warnings



- USE COVER BOLTS CLASS A4-70
- DO NOT OPEN WHEN AN EXPLOSIVE ATMOSPHERE IS PRESENT
- POTENTIAL ELECTROSTATIC CHARGING HAZARD – SEE INSTRUCTIONS
- FOR INDOOR USE

- TO REDUCE THE RISK OF IGNITION OF HAZARDOUS ATMOSPHERES, CONDUIT RUNS MUST HAVE A SEALING FITTING CONNECTED WITHIN 18 INCHES OF CONDUIT

### AVERTISSEMENT:

- UTILISER COUVRIR BOULONS CLASSE A4-70
- NE PAS OUVRIR UN PRESENCE D'ATMOSPHERE EXPLOSIVE
- DANGER POTENTIEL CHARGE ÉLECTROSTATIQUE - VOIR LES INSTRUCTIONS
- POUR USAGE INTÉRIEUR
- POUR RÉDUIRE LE RISQUE D'INFLAMMATION DES ATMOSPHÈRES DANGEREUSES, LES CONDUITES DE CONDUIT DOIVENT AVOIR UN RACCORD D'ÉTANCHÉITÉ RACCORDÉ À MOINS DE 18 POUCHES DE L'ENFERMEMENT

## 2) Rating & Marking Information

The GNExCP7PT callpoints meet the following standards for Fire Alarm System Use:

UL 38 8th Edition 10/4/2013 Manual Signaling Boxes for Fire Alarm Systems  
 ULC-S528 3rd Edition 2014-10 Manual Stations For Fire Alarm Systems, Including Accessories

### 2.1 NEC & CEC Class / Division Ratings for US / Canada

The GNExCP7PT callpoints comply with the following standards:

UL 60079-0:2017 (Ed 6): Explosive Atmospheres - Part 0: Equipment - General requirements  
 UL 60079-1:2015 (Ed7): Explosive Atmospheres - Part 1: Equipment protection by flameproof enclosures "d"  
 UL 60079-31:2012 (Ed 2): Explosive Atmospheres - Part 31: Equipment dust ignition protection by enclosure "t"

The Callpoints are rated as follows:

Class I Div 2 Group ABCD T5 Ta -55°C to +70°C  
 Class I Div 2 Group ABCD T6 Ta -55°C to +60°C  
 Class II Div 2 Group FG T4 Ta -55°C to +70°C  
 Class III Div 1 & 2 Ta -55°C to +70°C

Installation must be carried out in compliance with the National Electric Code / Canadian Electric Code

### 2.2 NEC Class / Zone ratings US

The Callpoints are rated as follows:

Class I Zone 1 AEx db IIC T5 Gb (Ta -55°C to +70°C)  
 Class I Zone 1 AEx db IIC T6 Gb (Ta -55°C to +60°C)  
 Zone 21 AEx tb IIIC T135°C Db (Ta -55°C to +70°C)

Installation must be carried out in compliance with the National Electric Code.

### 2.3 CEC Class / Zone ratings Canada

The GNExCP7PT callpoints comply with the following standards:

CSA C22.2 NO. 60079-0:2015 (Ed 3) Explosive Atmospheres – Part 0: Equipment – General requirements  
 CSA C22.2 NO. 60079-1:2016 (Ed 3): Explosive Atmospheres – Part 1: Equipment protection by flameproof enclosures "d"  
 CSA C22.2 NO. 60079-31:2015 (Ed 2): Explosive Atmospheres – Part 31: Equipment dust ignition protection by enclosure "t"

The Callpoints are rated as follows:

Class I Zone 1 Ex db IIC T5 Gb X (Ta -55°C to +70°C)  
 Class I Zone 1 Ex db IIC T6 Gb X (Ta -55°C to +60°C)  
 Zone 21 Ex tb IIIC T135°C Db (Ta -55°C to +70°C)

Installation must be carried out in compliance with the Canadian Electric Code.

## 2.4 ATEX / IECEx / UKEX Certification

The GNEXP7PT callpoints comply with the following standards:

EN60079-0:2018 / IEC60079-0:2017 (Ed 7): Explosive Atmospheres – Part 0: Equipment. General requirements  
 EN60079-1:2014 / IEC60079-1:2014 (Ed 7): Explosive Atmospheres - Part 1: Equipment protection by flameproof enclosures "d"  
 EN 60079-31:2014 / IEC 60079-31:2013 (Ed 2): Explosive Atmospheres - Part 31: Equipment dust ignition protection by enclosure "t"

All units have a rating label, which carries the following important information: -

**Model No.:** GNEXP7-PT-S (Single Switch)  
 GNEXP7-PT-D (Dual Switch)

**Input Voltage:** DC Units 48Vdc Max  
 AC Units 250Vac max (units without series or end-of-line devices only)

Ex db IIC T5 Gb Ta. -55 to +70°C  
 Ex db IIC T6 Gb Ta. -55 to +60°C  
 Ex tb IIIC T90°C Db Ta. -55° to +70°C

**Certificate No.** DEMKO 19 ATEX 2101X  
 IECEX ULD 19.0007X  
 UL21UKEX2134X

ATEX Marking  
 Equipment Group and  
 Category:

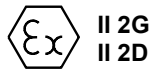

CE Marking  
 Notified Body No.



UKCA Marking  
 Notified Body No.



The units can be installed in locations with the following conditions:

### Area Classification Gas:

Zone 1	Explosive gas air mixture likely to occur in normal operation.
Zone 2	Explosive gas atmosphere not likely to occur in normal operation but may be present for short periods.

### Gas Groupings:

Group IIA	Propane
Group IIB	Ethylene
Group IIC	Hydrogen and Acetylene

### Temperature Classification:

T1	450°C
T2	300°C
T3	200°C
T4	135°C
T5	100°C
T6	85°C (only up to Tamb 60°C)

### Area Classification Dust:

Zone 21	Explosive dust air mixture likely to occur in normal operation.
Zone 22	Explosive dust air mixture not likely to occur in normal operation, and if it does, it will only exist for a short time.

### Dust Groupings:

Group IIIA	Combustible Flyings
Group IIIB	Non-conductive Dust
Group IIIC	Conductive Dust

### Maximum Surface Temperature for Dust Applications:

90°C  
 135°C

**IP Rating:** IP66/67 to EN/IEC60529 and IP6X to EN/IEC60079-0, EN/IEC60079-31

**Equipment Category:** 2G / 2D

**Equipment Protection Level:** Gb, Gc, Db, Dc

**Ambient Temperature Range:** -55°C to +70°C

## 3) Installation Requirements

The unit must only be installed by suitably qualified personnel in accordance with the latest issues of the relevant standards:

EN60079-14 / IEC60079-14: Explosive atmospheres - Electrical installations design, selection and erection

EN60079-10-1 / IEC60079-10-1: Explosive atmospheres - Classification of areas. Explosive gas atmospheres

The installation of the unit must also be in accordance with any local codes that may apply and should only be carried out by a competent electrical engineer who has the necessary training.

The equipment must not be installed with any obstruction to the flanged flameproof joint any closer than permitted as per EN/IEC60079-14, table 13.

## 4) Special Conditions of Use

The stainless steel button is not earthed and may generate an ignition-capable level of electrostatic charges. It has a max capacitance of 6.33pF according to EN/IEC60079-0, clause 7.5.

Equipment is permitted to be wall mounted only in vertical position. The enclosure base is permitted in two mounting positions, with the double entry lowermost or uppermost.

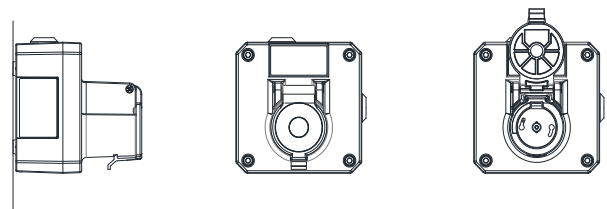

No repair to the Flamepaths is permitted

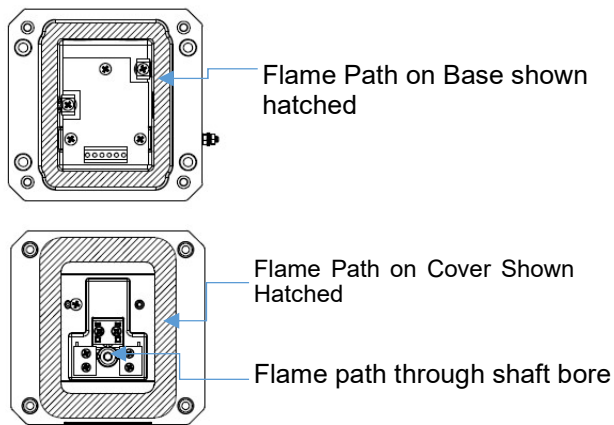

## 5) Location and Mounting

The location of the call point should enable ease of access for operation and testing. The unit should be mounted using the 4 off fixing holes which will accept up to M5 sized fixings. They should only be fixed to services that can carry the weight of the unit.

To gain access to the mounting holes in the base the front cover must be removed. See Section 6.

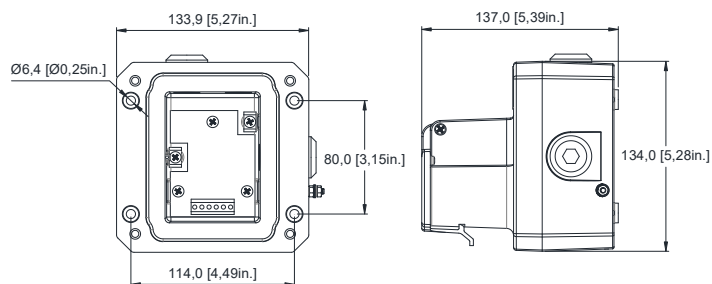

Fig. 1 View of base unit showing fixing centres (in mm).

## 6) Access to the Flameproof Enclosure



Warning – High voltage may be present, risk of electric shock. DO NOT open when energised, disconnect power before opening.



Warning – Hot surfaces. External surfaces and internal components may be hot after operation, take care when handling the equipment.

To access the Ex d chamber, remove the four off M6 x 50 stainless steel A4-70 cap head cover bolts and withdraw the flameproof cover taking extreme care not to damage the flameproof joints in the process. M6 cover screws are Class A4-70 stainless steel and only screws of this category can be used for the enclosure.

On completion of the installation the flameproof joint surfaces should be inspected to ensure that they are clean and that they have not been damaged during installation.

Once the screws are removed the cover will hang down out of the way to gain access to the terminals, the internal earth terminal and mounting hole recesses.

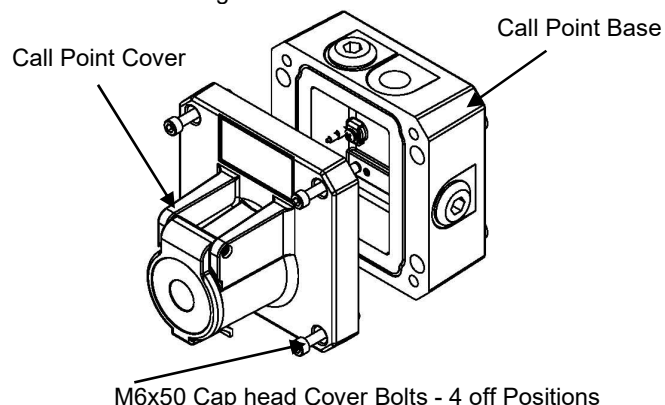

Fig. 2 Accessing the Explosion proof Enclosure.

Check that the earth bonding wire between the two castings is secure and the 'O' ring seal is in place.

When fitting the flameproof cover ensure the cover is sitting flat and correctly positioned on the base. Insert the M6 x 50 stainless steel A4-70 Cap Head cover bolts and fully tighten down (tightening torque 3.5Nm), ensuring no gap is visible between the cover and base of the enclosure.

The enclosure is non-conductive. These may generate an ignition-capable level of electrostatic charges under certain extreme conditions. The user should ensure that the equipment is not installed in a location where it may be subjected to external conditions that might cause a build-up of electrostatic charges on non-conducting surfaces.

Additionally, cleaning of the equipment should be done only with a damp cloth.

Caution do not change factory applied finishes

## 7) Earthing

The units are provided with internal and external earth terminals which are mounted in the base of the unit.

Internal earthing connections should be made to the Internal Earth terminal in the base of the housing using a ring crimp terminal to secure the earth conductor under the earth clamp. The earth conductor should be at least equal in size and rating to the incoming power conductors.

When using the internal earth terminal ensure that the stainless steel M4 flat washer is between the incoming earth wire and the enclosure.

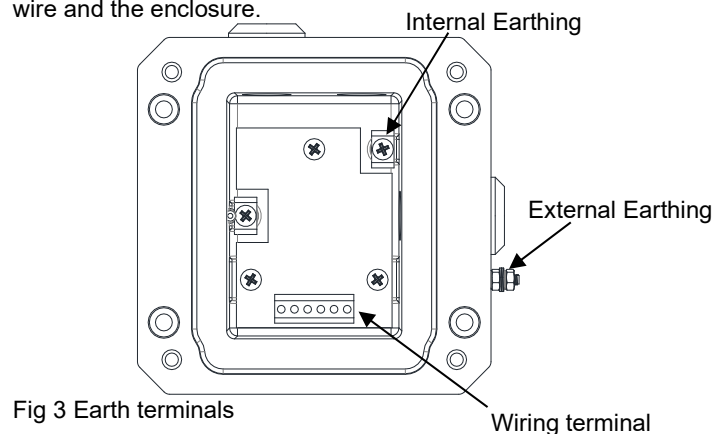

Fig 3 Earth terminals

## 8) Power Supply Selection

### Electrical Ratings

250Vac max. / 3.33A max  
 48Vdc max. / 1.0A max  
 24Vdc max / 3.0A max

Electrical connections are to be made into the terminal blocks / DIN rail provided. See Section 11 for wiring options.

## 9) Selection of Cable, Cable Glands, Blanking Elements & Adapters

For high ambient temperatures the cable entry temperature or the cable branching point temperature may exceed 60°C and therefore suitable heat resisting cables and cable glands must be used, with a rated service temperature of at least the values stated below:

For Single Switch model GNExCP7-PT-S:

Max. ambient temperature (°C)	55	60	65	70
req. Cable / Cable Gland rating: (°C)	80	85	90	95

For Dual Switch model GNExCP7-PT-D:

Max. ambient temperature (°C)	45	50	55	60	65	70
req. Cable / Cable Gland rating: (°C)	80	85	90	95	100	105

The cable gland entries have an M20 x 1.5 entry thread. Only suitably rated and ATEX / IECEx / UKEX certified cable glands which must be suitable for the type of cable being used and also meet the requirements of the current Ex 'd' flameproof installation standards EN 60079-14 / IEC60079-14.

When only one cable entry is used the other entries must be closed with suitably rated and ATEX / IECEx / UKEX certified blanking plugs.

If a high IP (Ingress Protection) rating is required then a suitable sealing washer must be fitted under the cable glands or blanking plugs.

The GNExCP7 Call Point range can be supplied with the following types of adapters:

M20 to ½" NPT  
 M20 to ¾" NPT  
 M20 to M25

It is important to note that stopping plugs cannot be fitted onto adapters, only directly onto the M20 entries.

Any other adapters used must be suitably rated and ATEX / IECEx / UKEX certified adapters.

## 10) Cable Connections

Electrical Connections are to be made into the terminal blocks using solid or stranded wire. See section 6 of this manual for access to the flameproof enclosure.

Wires having a cross sectional area between 0.5 mm<sup>2</sup> to 2.5mm<sup>2</sup> (AWG 20 – 14) can be connected to each terminal way.

Wiring methods shall be in accordance with CSA C22.1, Canadian Electrical Code, Part I, Safety Standard for Electrical Installations, Section 32; and CAN/ULC-S524, Standard for Installation of Fire Alarm Systems

If an input and output wire is required the 2-off Live/Neutral or +/- terminals can be used. If fitting 2-off wires to one terminal way the sum of the 2-off wires must be a maximum cross sectional area of 2.5mm<sup>2</sup>.

Strip wires to 8mm. Wires may also be fitted using ferrules.

Terminal screws need to be tightened down with a tightening torque of 0.45 Nm / 5 Lb-in.

When connecting wires to the terminals great care should be taken to dress the wires so that when the cover is inserted into the chamber the wires do not exert excess pressure on the terminal blocks. This is particularly important when using cables with large cross sectional areas such as 2.5mm<sup>2</sup>.

## 11) Wiring Unit

The units come with two options for the terminal block.

A DIN rail version which has 8-way connection and allows for full configuration at factory or limited wiring of EOL devices by customer.

The PCB Terminal Version has a 6-way connector but is designed to allow for full configuration with Series and EOL devices in a number of wiring configurations.

For EOL and Series device limitations and configurations see Section 12.

For wiring schematic see document D202-06-201

### Wiring Connections for 8-Way DIN Rail

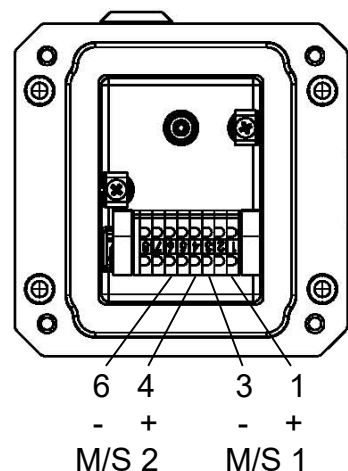

Fig. 4 DIN Rail in Base

## Wiring Connections For 6-Way PCB Terminal Board

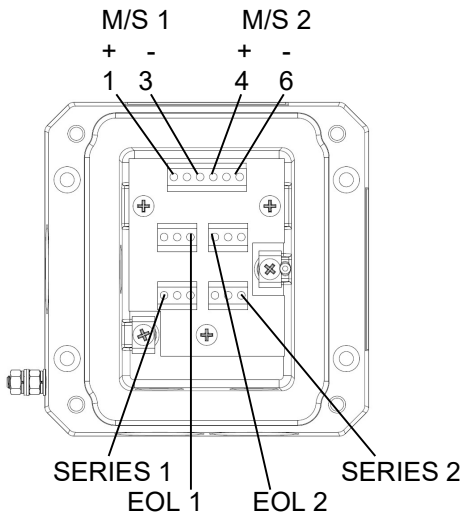

Fig. 5 PCB Terminal Block in Base

See section 12 and pages 7 & 8 for details of adding Series and EOL devices on the PCB. This can either be done at the order stage or added to the correct terminal blocks afterward. All devices must comply with the requirements stipulated in section 12.

### 12) End-of-Line and Series Devices

All models can be fitted with series resistors, end-of-line monitoring resistors, monitoring diodes, zener diodes and also specific customer modules if supplied with direct current up to 48Vdc and limited to a maximum total power consumption no greater than 6.224W.

Min. resistor values and current limitations must be observed depending on supply voltage and type of components fitted. If a combination of resistors / diodes / zener diodes is used, values for all components must be observed and lowest current limit for either component becomes overall limit.

Current limitation for units fitted with end-of-line resistors, diodes or zener diodes must be ensured by using a current limited power supply or fitting a current limiting resistor at the control panel (not provided).

The following table 1 shows limitations for all possible variations:

EOL (End of line) device;	Series (In line) device;
• resistor – ExxxR	• resistor – SxxxR
• diode – ED1	• diode – SD1
• zener – ExxxZ	• zener – SxxxZ
	• LED

Microswitch 1 = M/S 1

Microswitch 2 = M/S 2

The unit can be wired with a maximum of 4 module devices

Type of component fitted	Supply voltage 24Vdc		Supply voltage 48Vdc	
	value	Max. current mA	value	Max. current mA
End-of-Line Resistor *See note	min. 470R/2W or min. 2k2/0.5W	3000	min. 2k2/2W or min. 8k2/ 0.5W	1000
End-of-Line Diode Type 1N5401	2W	59.13	2W	25.26
Series Resistor *See note	min. 470R / 2W or min. 2k2/0.5W	3000	min. 2k2/2W or min. 8k2/0.5W	1000
Series Diode Type 1N5401	2W	59.13	2W	25.26
Series Zener Diode Type 1N5333B	3.3V	230	3.3V	230
	4.7V	162	4.7V	162
	5.1V	149	5.1V	149
	5.6V	136	5.6V	136
	6.2V	122	6.2V	122
	6.8V	112	6.8V	112
	10V	76	10V	76
	12V	63	12V	63

Note: - The maximum voltage stated must not be exceeded, as the internal resistor modules are rated as compliant with Ex d according to the unit voltage.

If lower value resistors than seen on table are required it may be possible to configure but seek advice from E2S to ensure compliance is still maintained.

### 13) Testing unit operation

The PT call points need to have the protective flip lid opened first and then the main plunger pressed in.

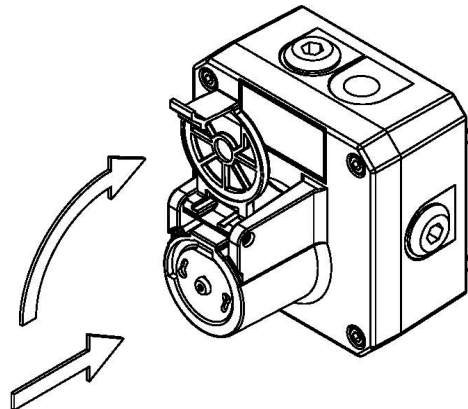
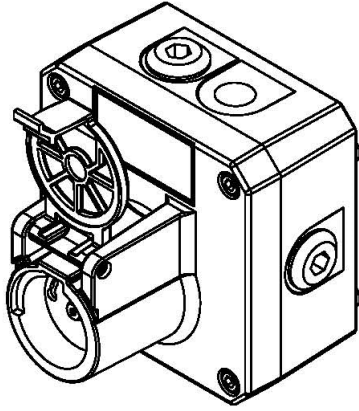

Fig 7 -PT Push Action



The plunger will remain in the down/latched position until the unit is reset. This is done by lifting the plunger back up using the tool reset key provided.

## 14) Maintenance, Overhaul & Repair

Maintenance, repair and overhaul of the equipment should only be carried out by suitably qualified personnel in accordance with the current relevant standards:

To avoid a possible electrostatic charge the unit must only be cleaned with a damp cloth.

Units must not be opened while an explosive atmosphere is present.

EN60079-19 Explosive atmospheres - Equipment repair, overhaul and reclamation

EN 60079-17 Explosive atmospheres - Electrical installations inspection and maintenance

## 15) SIL 2 Reliability Data

Reliability and Functional safety IEC/EN61508 which has been assessed and is considered suitable for use in low demand safety function:

- Random Hardware Failures and Systematic Failures (route 2H)
- As an unvoted item (i.e. hardware fault tolerance of 0) at SIL 2

The product was assessed against failure modes:

- Failure to close a contact when the call point is struck with specified force
- Failure to open a contact when the call point is struck with specified force
- Spurious output despite no input

Integrity in respect of failure to close	SIL 2
System Type	A
Hardware Fault Tolerance	0
Safe Failure Fraction (credible claim)	75%
PFD (hazardous failure)	$2.3 \times 10^{-3}$
Proof Test Interval	Up to 1 year

Single Microswitch only - Circuit shown with Unit un-operated  
GNExCP7 UL38 DIN Rail / Terminal Version

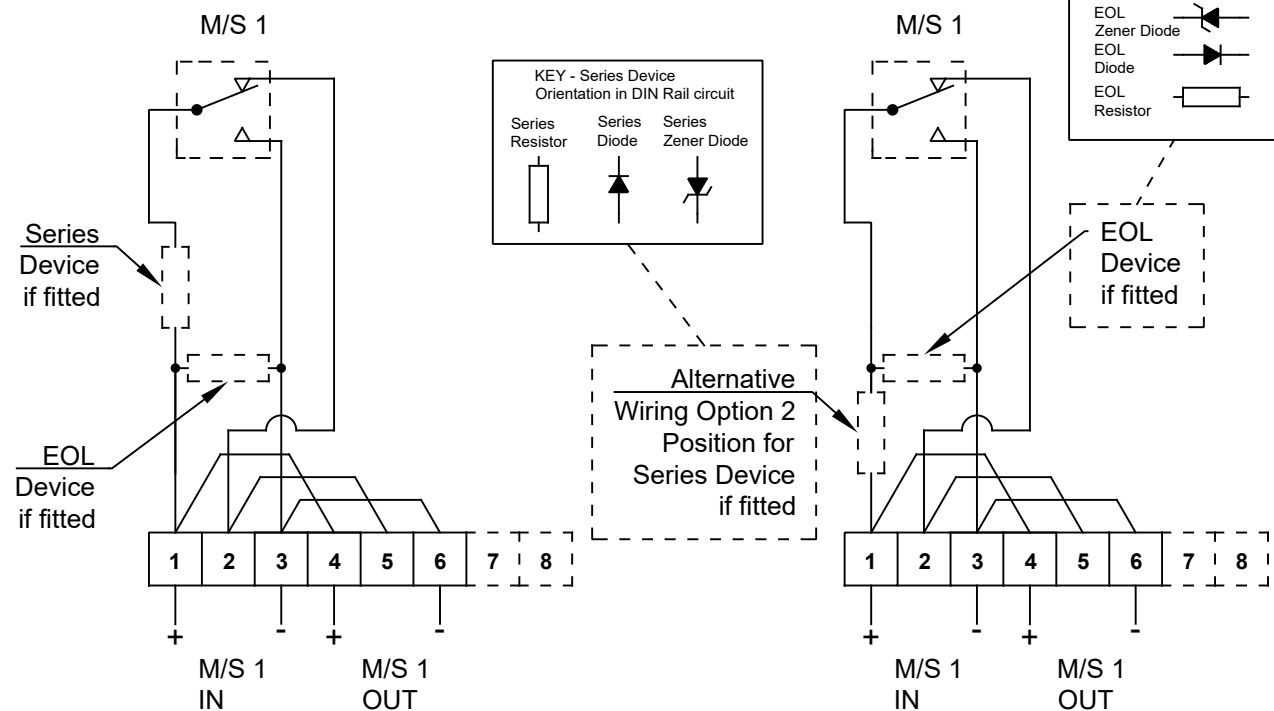

Double Microswitch only - Circuit shown with Unit un-operated  
GNExCP7 UL38 DIN Rail / Terminal Version

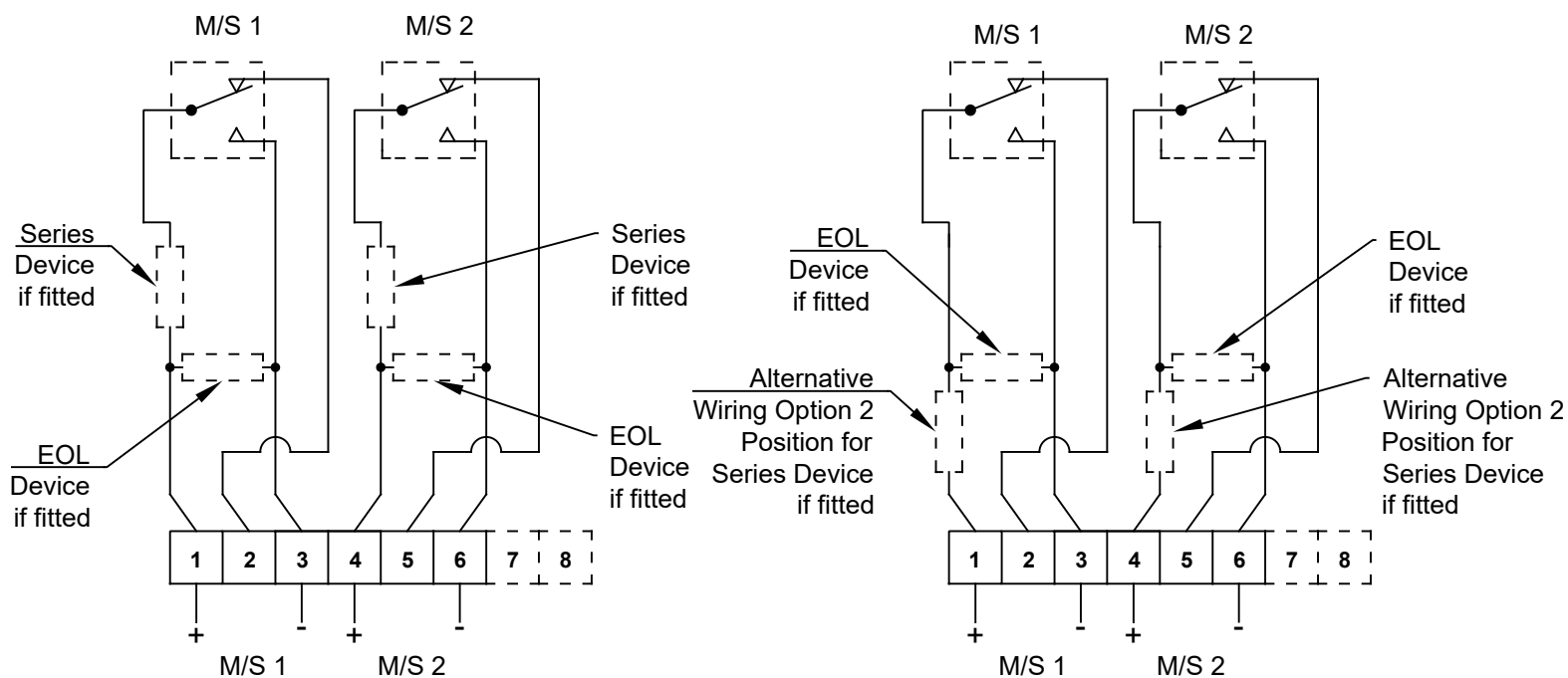

ISSUE	MOD No.	INITIAL/DATE
3	ACN0102	Version BG Added ; wire colour Removed. RNP 15-04-2022

KEY - Series Devices  
Orientation in PCB  
Circuit

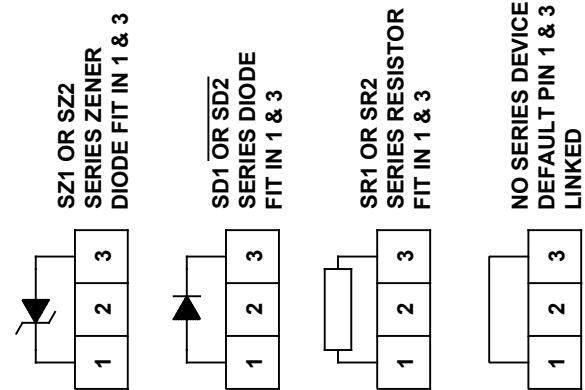

KEY - EOL Devices  
Orientation in PCB  
Circuit

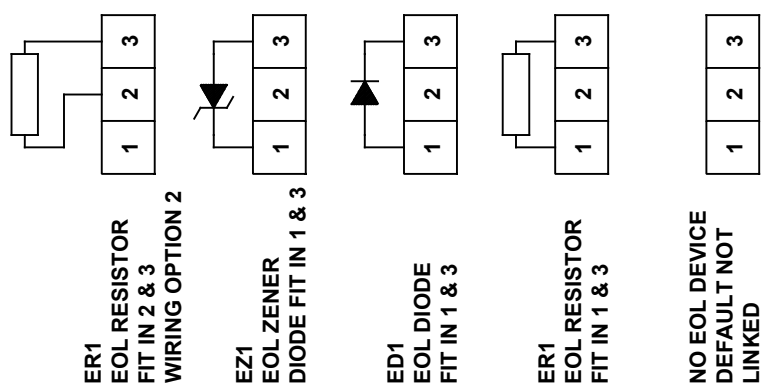

Optional Single or Double Microswitch  
Circuit shown with Unit un-operated : GNExCP7 UL38 PCB  
Version M/S 1 M/S 2

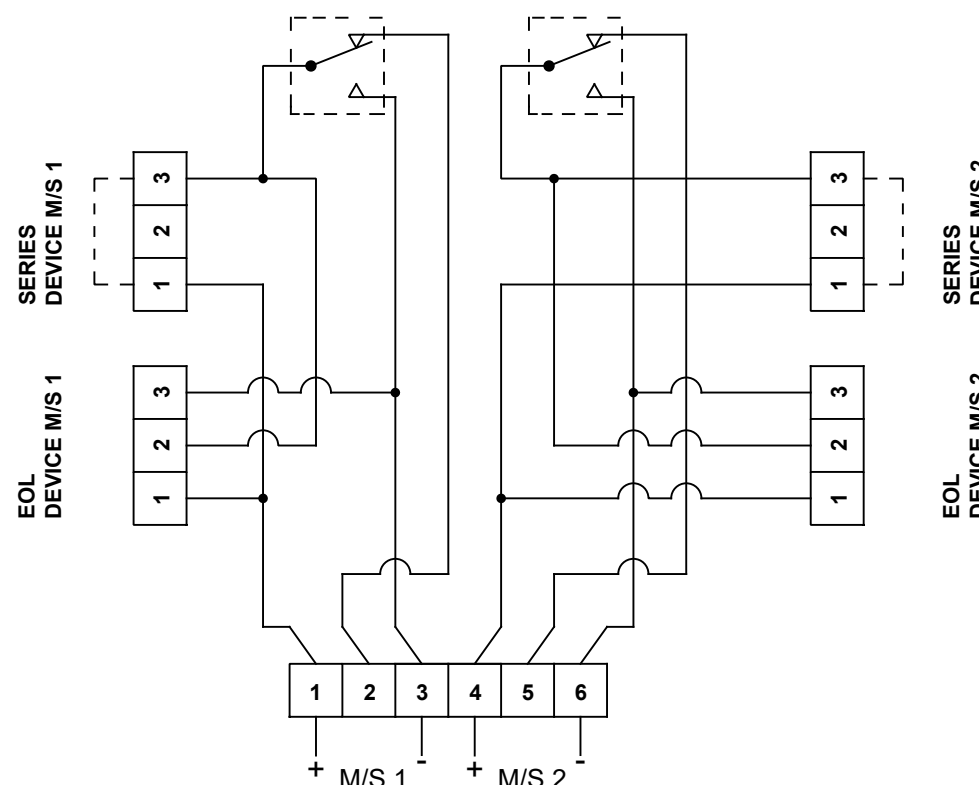

Single Microswitch only - Circuit shown with Unit un-operated  
GNExCP7 UL38 DIN Rail / Terminal Version Optional Module

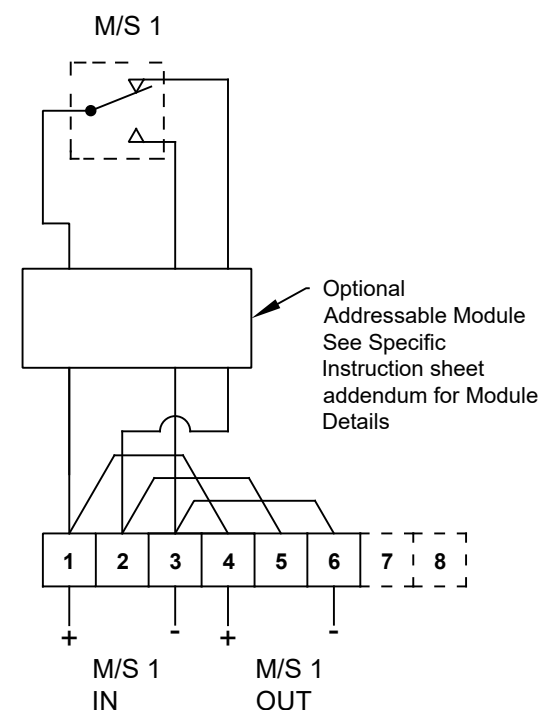

DRAWING TO BS8888:2000  
GEOMETRIC TOLERANCES TO ISO1101:1983  
LINEAR DIMENSIONAL TOLS +/-0.35mm  
ANGULAR DIMENSIONAL TOLS +/-2 deg

DRAWN R.S. RAIT DATE 27-06-2019

CHECKED B. ISARD DATE 27-06-2019

APPROVED R.N.POTTS DATE 27-06-2019

STANDARDS

GNExCP7PT UL 38

SURFACE FINISH WEIGHT (Kg)

MATERIAL

ALTERNATIVE MATERIAL

THIS DRAWING AND ANY INFORMATION OR DESCRIPTIVE MATTER THEREIN IS COMMUNICATED IN CONFIDENCE AND IS THE COPYRIGHT PROPERTY OF EUROPEAN SAFETY SYSTEMS LTD. NEITHER THE WHOLE OR ANY EXTRACT MAY BE DISCLOSED, LOANED, COPIED OR USED FOR MANUFACTURING OR TENDERING PURPOSES WITHOUT THEIR WRITTEN CONSENT.

© EUROPEAN SAFETY SYSTEMS LTD. AS PER LATEST DATE OF ISSUE SHOWN ABOVE



EUROPEAN SAFETY SYSTEMS LTD  
IMPRESS HOUSE  
MANSELL ROAD  
ACTON  
LONDON W3 7QH  
WWW.E2S.COM

ALL DIMENSIONS IN MM  
IF IN DOUBT, ASK -  
DO NOT SCALE

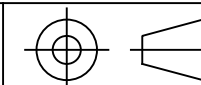

A3

TITLE GNExCP7 UL38 CALL POINT  
WIRING / CIRCUIT OPERATION DIAGRAM

SCALE NTS

SHEET 1 OF 2

DRAWING NUMBER D202-06-201

8	9	10
ISSUE	MOD No.	INITIAL/DATE
3	ACN0102	See Sheet 1 RNP 15-04-2022

GNExCP7 [ ] [S] [P] SWITCH TYPE: [S] - Single Microswitch TERMINAL TYPE [P] - PCB  
GNExCP7 [ ] [D] [P] SWITCH TYPE: [D] - Double Microswitch TERMINAL TYPE [P] - PCB

Operation Single or Double Microswitch  
Circuit shown with Double Microswitch, GNExCP7 PCB Version  
Device selected only as an example:  
On M/S 1: EOL Zener Diode and Series Resistor  
On M/S 2: EOL resistor and no Series device

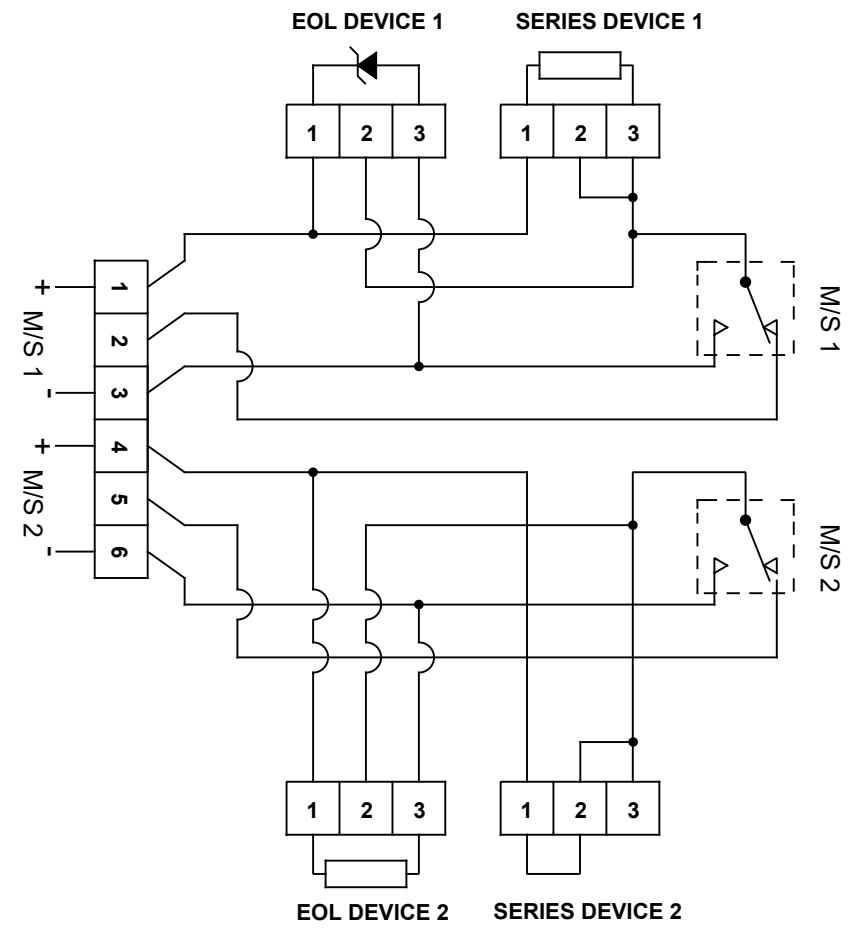
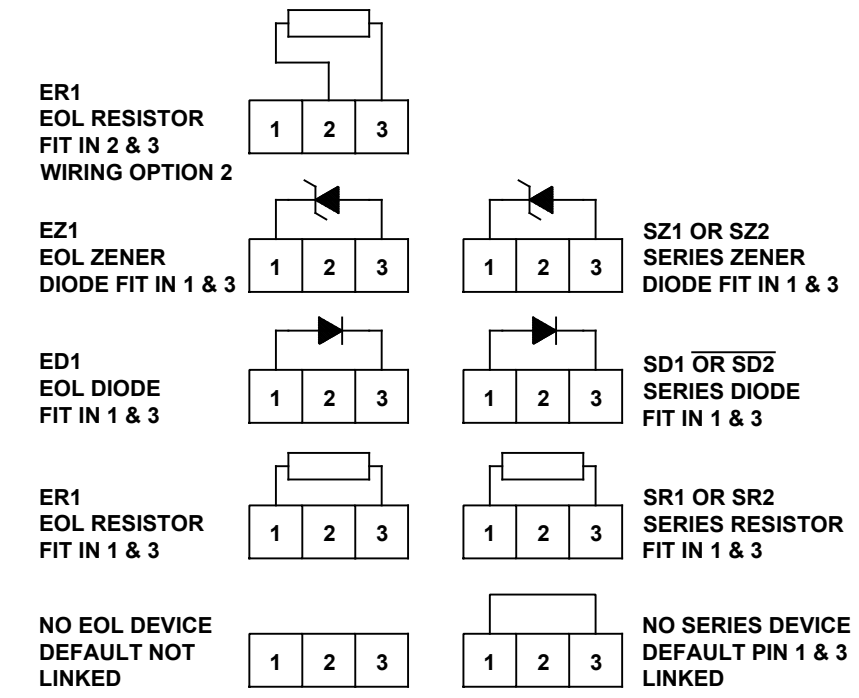

1A - Circuit as shown in Unoperated condition  
Terminals +(1) & -(3) M/S 1 and +(4) & -(6) M/S 2 open  
Terminals +(1) & (2) M/S 1 and +(4) & (5) M/S 2 closed

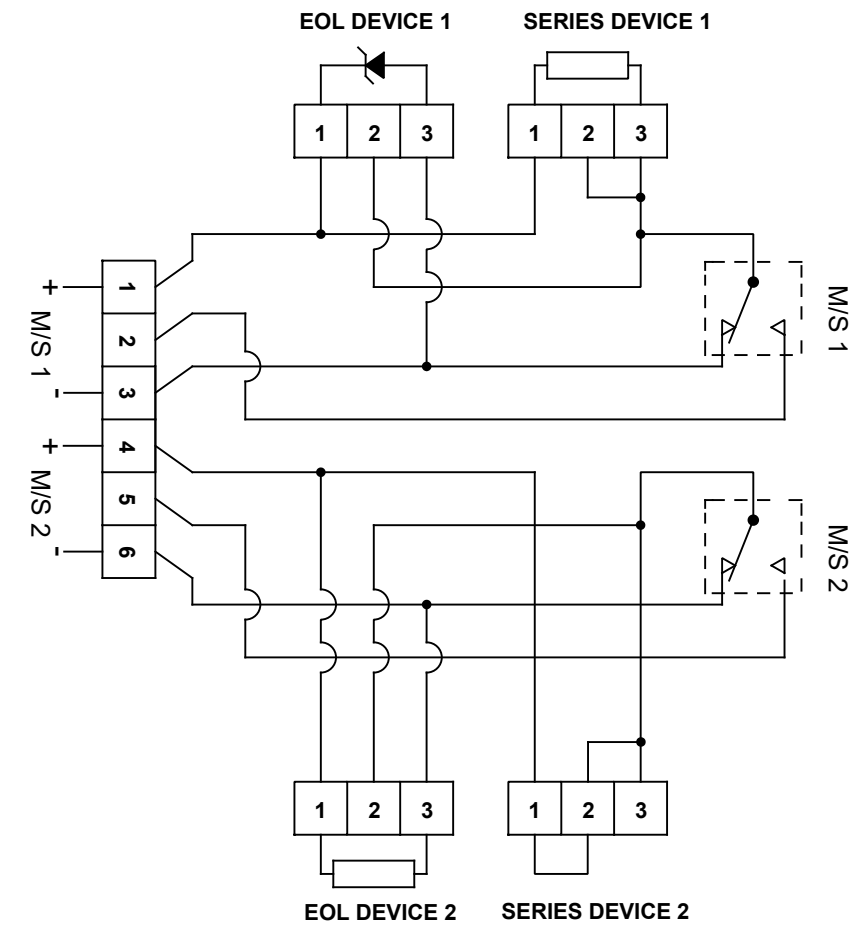

1B - Circuit as shown in Operated condition  
Terminals +(1) & (2) M/S 1 and +(4) & (5) M/S 2 open  
Terminals +(1) & -(3) M/S 1 and +(4) & -(6) M/S 2 closed

DRAWING TO BS8888:2000  
GEOMETRIC TOLERANCES TO ISO1101:1983  
LINEAR DIMENSIONAL TOLS +/-0.35mm  
ANGULAR DIMENSIONAL TOLS +/-2 deg  
STANDARDS  
GNExCP7PT UL 38

DRAWN	DATE
R.S. RAIT	27-06-2019
CHECKED	DATE
B. ISARD	27-06-2019
APPROVED	DATE
R.N.POTTS	27-06-2019

SURFACE FINISH	WEIGHT (Kg)
MATERIAL	
ALTERNATIVE MATERIAL	

THIS DRAWING AND ANY INFORMATION OR DESCRIPTIVE MATTER THEREIN IS COMMUNICATED IN CONFIDENCE AND IS THE COPYRIGHT PROPERTY OF EUROPEAN SAFETY SYSTEMS LTD. NEITHER THE WHOLE OR ANY EXTRACT MAY BE DISCLOSED, LOANED, COPIED OR USED FOR MANUFACTURING OR TENDERING PURPOSES WITHOUT THEIR WRITTEN CONSENT.  
© EUROPEAN SAFETY SYSTEMS LTD.  
AS PER LATEST DATE OF ISSUE SHOWN ABOVE

EUROPEAN SAFETY SYSTEMS LTD  
IMPRESS HOUSE  
MANSELL ROAD  
ACTON  
LONDON W3 7QH  
WWW.E2S.COM

ALL DIMENSIONS IN MM IF IN DOUBT, ASK - DO NOT SCALE			A3
TITLE GNExCP7 UL38 CALL POINT WIRING / CIRCUIT OPERATION DIAGRAM			
SCALE NTS	SHEET 2 OF 2	DRAWING NUMBER D202-06-201	



# EU Declaration of Conformity



Manufacturer: European Safety Systems Ltd.  
Impress House, Mansell Road, Acton  
London, W3 7QH  
United Kingdom

Authorised Representative: E2S Warnsignaltechnik UG  
Charlottenstrasse 45-51  
72764 Reutlingen  
Germany

Equipment Type: GNExCP7-BG, GNExCP7-PB, GNExCP7-PM, GNExCP7-PT

---

## Directive 2014/34/EU: Equipment and Protective Systems for use in Potentially Explosive Atmospheres (ATEX)

Notified Body for EU type Examination (Module B):	UL International Demko A/S Notified Body No.: 0539 Borupvang 5A, 2750 Ballerup, Denmark
EU-type Examination Certificate (Module B):	DEMKO 19 ATEX 2101X
Notified Body for Quality Assurance Notification / Conformity to EU-type based on quality assurance of the production process (Module D):	Sira Certification Service Notified Body No.: 2813 CSA Group Netherlands B.V, Utrechtseweg 310, 6812 AR, Arnhem, Netherlands
Quality Assurance Notification (Module D):	SIRA 05 ATEX M342
Provisions fulfilled by the equipment:	II 2G Ex d IIC T6...T5 Gb II 2D Ex tb IIIC T90°C...T80°C Db
Standards applied:	EN 60079-0:2018 EN 60079-1:2014 EN 60079-31:2014 IP6X Dust Protection to EN60079-0 / EN60079-31

## Directive 2014/30/EU: Electromagnetic Compatibility Directive (EMC)

Standards applied:	EN 61000-6-1:2007 EN 61000-6-2:2005 EN 61000-6-3:2007 / A1:2011 / AC: 2012 EN 61000-6-4:2007 / A1: 2011
--------------------	--

## Directive 2011/65/EU: Restriction of the use of certain hazardous substances in electrical and electronic equipment (RoHS)

The product and all the components contained within it are in accordance with the restriction of the use of hazardous substances in electrical and electronic equipment, including amendment by Directive 2015/863/EU.

## Regulation (EC) 1907/2006: Registration, Evaluation, Authorisation and Restriction of Chemicals (REACH)

The product and all the components contained within it are free from substances of very high concern.

## Other Standards and Regulations

EN 60529:1991 + A1:2000 + A2:2013. - Degrees of protection provided by enclosures (IP code) – enclosure rated IP66/67

---

On behalf of European Safety Systems Ltd., I declare that, on the date the equipment accompanied by this declaration is placed on the market, the equipment conforms with all technical and regulatory requirements of the above listed directives, regulations and standards.

This Declaration is issued under the sole responsibility of the manufacturer.

A handwritten signature in black ink, appearing to read 'Martin Streetz'.

Martin Streetz  
Quality Assurance Manager

Document No.:	DC-078_Issue_E
Date and Place of Issue:	London, 23/12/2020



# UKCA Declaration of Conformity



Manufacturer: European Safety Systems Ltd.  
Impress House, Mansell Road, Acton  
London, W3 7QH  
United Kingdom

Equipment Type: GNExCP7-BG, GNExCP7-PB, GNExCP7-PM, GNExCP7-PT

Directive UKSI 2016:1107 (as amended by UKSI 2019:696) – Schedule 3A, Part 1 : Product or Protective System Intended for use in Potentially Explosive Atmospheres (UKCA)

Notified Body for UK type Examination (Module B):	UL International (UK) Ltd Notified Body No.: 0843 Unit 1-3 Horizon Kingsland Business Park, Wade Road, Basingstoke, Hampshire RG24 8AH UK
UK-type Examination Certificate (Module B):	UL21UKEX2134X
Notified Body for Quality Assurance Notification / Conformity to EU-type based on quality assurance of the production process (Module D):	Sira Certification Service Notified Body No.: 0518 Rake Lane, Eccleston, Chester CH4 9JN, UK
Quality Assurance Notification (Module D):	CSAE 22UKQAN0046
Provisions fulfilled by the equipment:	II 2G Ex d IIC T6...T5 Gb II 2D Ex tb IIIC T90°C... T80°C Db
Standards applied:	EN 60079-0:2018 EN 60079-1:2014 EN 60079-31:2014 IP6X Dust Protection to EN60079-0 / EN60079-31

Directive 2014/30/EU: Electromagnetic Compatibility Directive (EMC)

Standards applied:	EN 61000-6-1:2007 EN 61000-6-2:2005 EN 61000-6-3:2007 / A1:2011 / AC: 2012 EN 61000-6-4:2007 / A1: 2011
--------------------	--

Directive 2011/65/EU: Restriction of the use of certain hazardous substances in electrical and electronic equipment (RoHS)

The product and all the components contained within it are in accordance with the restriction of the use of hazardous substances in electrical and electronic equipment, including amendment by Directive 2015/863/EU.

Regulation (EC) 1907/2006: Registration, Evaluation, Authorisation and Restriction of Chemicals (REACH)

The product and all the components contained within it are free from substances of very high concern.

Other Standards and Regulations

EN 60529:1991 + A1:2000 + A2:2013. - Degrees of protection provided by enclosures (IP code) – enclosure rated IP66/67

On behalf of European Safety Systems Ltd., I declare that, on the date the equipment accompanied by this declaration is placed on the market, the equipment conforms with all technical and regulatory requirements of the above listed directives, regulations and standards.

This Declaration is issued under the sole responsibility of the manufacturer.

Martin Streetz  
Quality Assurance Manager

Document No.:  
Date and Place of Issue:

DC-099\_Issue\_A  
London, 24/02/2022