

INSTRUCTION & SERVICE MANUAL

AL105NH AlertAlight Combined Sounder LED Beacons

- -40°C to +66C (-40°F to 151°F)
- Type 4 / 4X / 3R / 13, IP66
- 1.8Kg (3.96lb)
- CE, UKCA
- All units UL Listed.

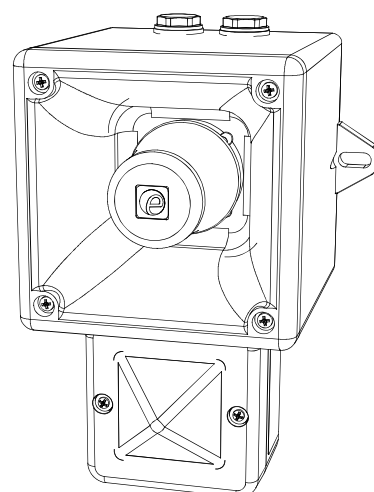

Unit Type Code	Nominal Voltage	Voltage Range	Nominal Sounder Current*	Nominal Beacon Current*	Nominal SPL	Max SPL	Average SPL
AL105NHDC024	#12 V dc	10-14Vdc	17mA	79.5mA	105.3dB(A) Tone 44 @ 1m	110.9dB(A) Tone 4 @ 1m	105.2dB(A) All tones @1m
	24V dc	16-33Vdc (Regulated)	33.5mA	87mA			
AL105NHDC048	48V dc	48-60Vdc	113mA	60mA			
AL105NHAC230	48V ac	48 - 260Vac 50/60Hz	42.5mA	60mA			
	115V ac		25mA	34mA			
	230V ac		17mA	19mA			

*Nominal current at nominal voltage, Tone 12 / 1Hz Flash Pattern; #Factory Default setting 24Vdc, beacon customer settable to 12Vdc

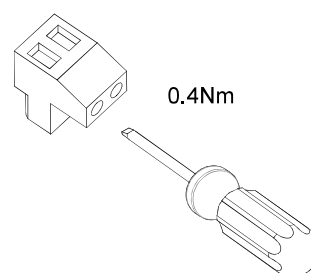
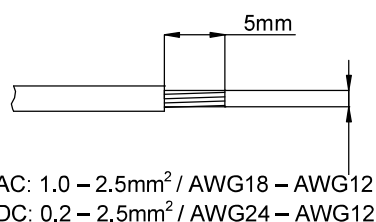

Attention: Installation must be carried out by an electrician in compliance with the latest codes and regulations.
 Attention: L'installation doit être effectuée par un électricien conformément aux derniers codes et réglementations.
 Achtung: Die Installation muss von einem Elektriker gemäß den neuesten Vorschriften und Bestimmungen durchgeführt werden.
 Attenzione: L'installazione deve essere eseguita da un elettricista in conformità con i codici e le normative più recenti.
 Atención: La instalación debe ser realizada por un electricista de acuerdo con los últimos códigos y regulaciones.
 Atenção: A instalação deve ser realizada por um eletricista de acordo com os códigos e regulamentos mais recentes.
 ВНИМАНИЕ: установка должна выполняться электриком в соответствии с последними нормами и правилами.



Attention: Disconnect from power source before installation or service to prevent electric shock
 Attention: Débranchez-le de la source d'alimentation avant l'installation ou l'entretien pour éviter tout choc électrique.
 Achtung: Vor Installation oder Wartung von der Stromquelle trennen, um einen Stromschlag zu vermeiden.
 Attenzione: scollegare dall'alimentazione prima dell'installazione o dell'assistenza per evitare scosse elettriche.
 Atención: desconéctelo de la fuente de alimentación antes de la instalación o el servicio para evitar descargas eléctricas.
 Atenção: Desconecte da fonte de alimentação antes da instalação ou serviço para evitar choque elétrico
 ВНИМАНИЕ: отключите от источника питания перед установкой или обслуживанием, чтобы предотвратить поражение электрическим током.

AC

(See D218-06-205)

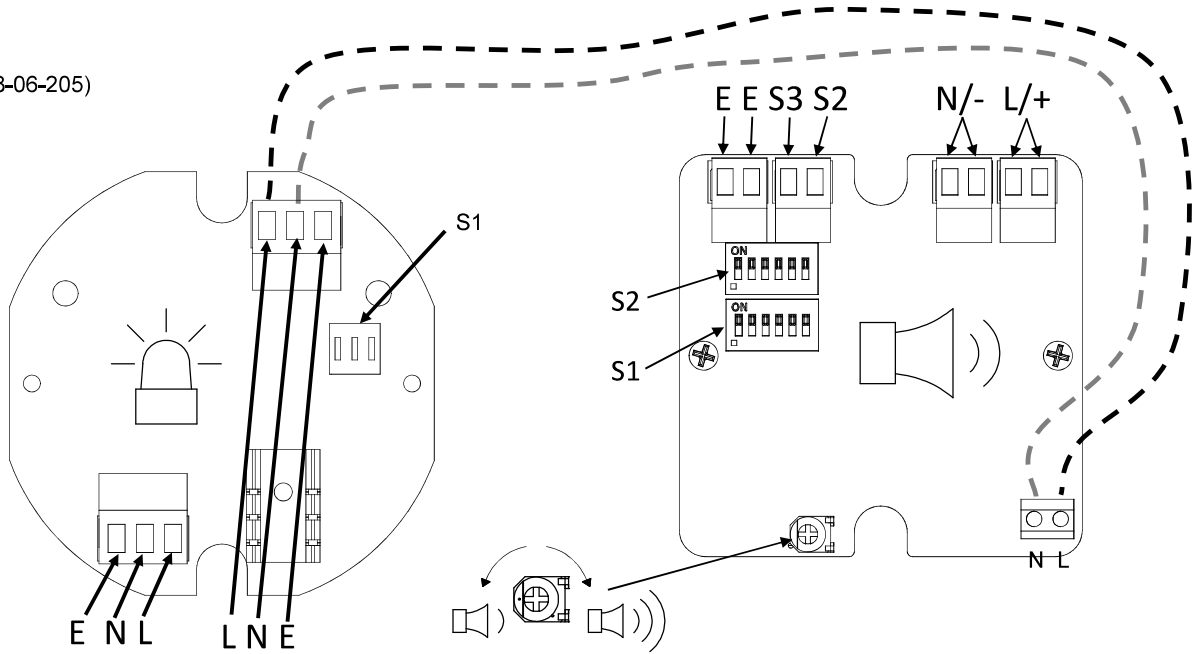

DC

(See D218-06-201)

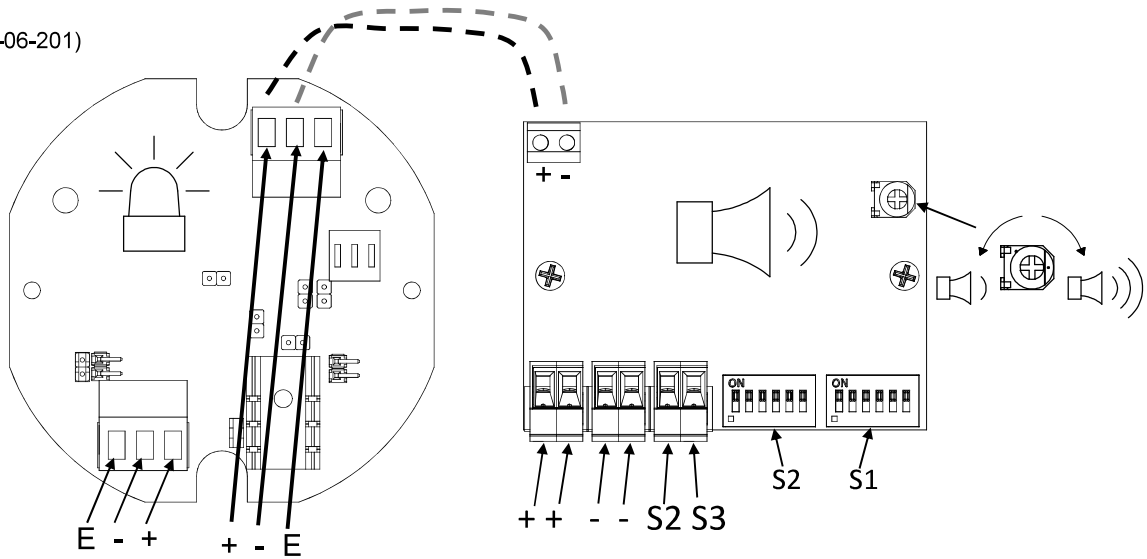

(AC & DC, See D221-95-001)

Default = S2 - Tone 1

Default = S1 - Tone 44

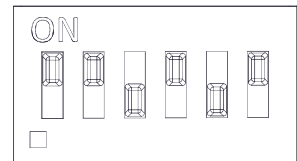
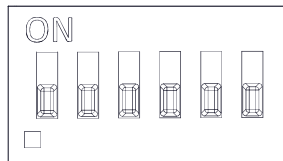

(ON = 1, OFF = 0)

INSTRUCTION & SERVICE MANUAL
AL105NH AlertAlight Combined Sounder LED Beacons

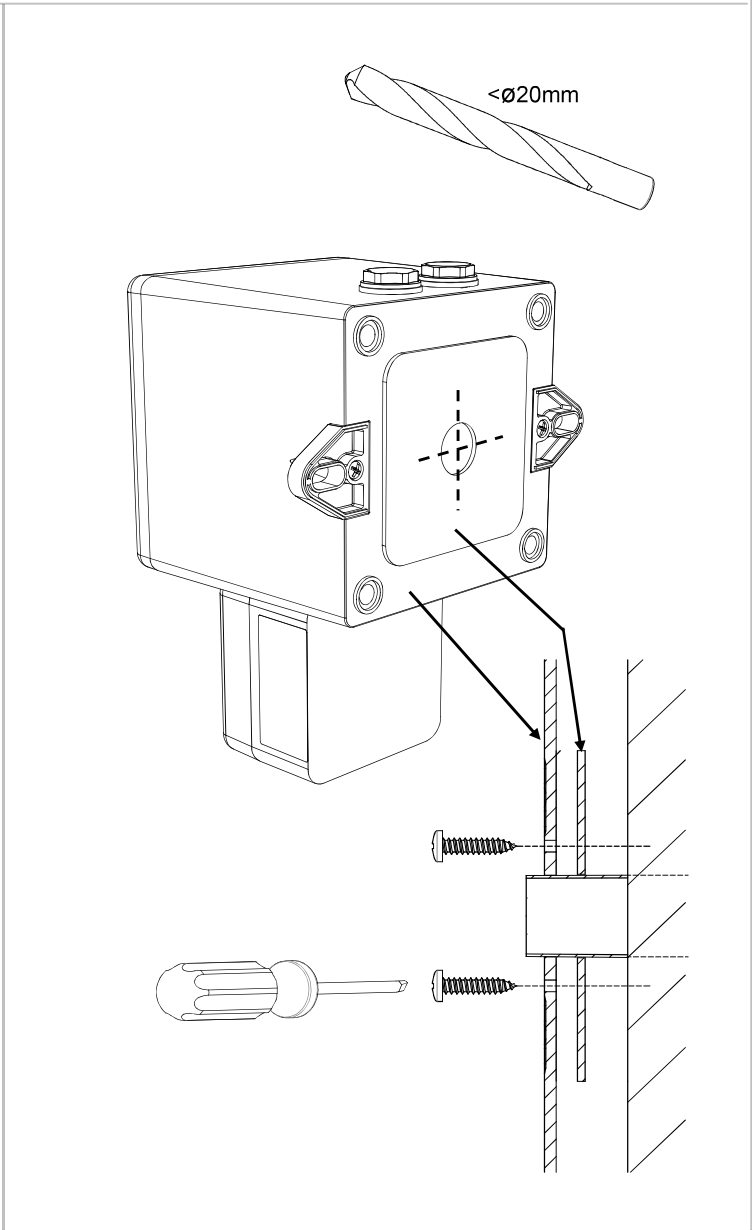
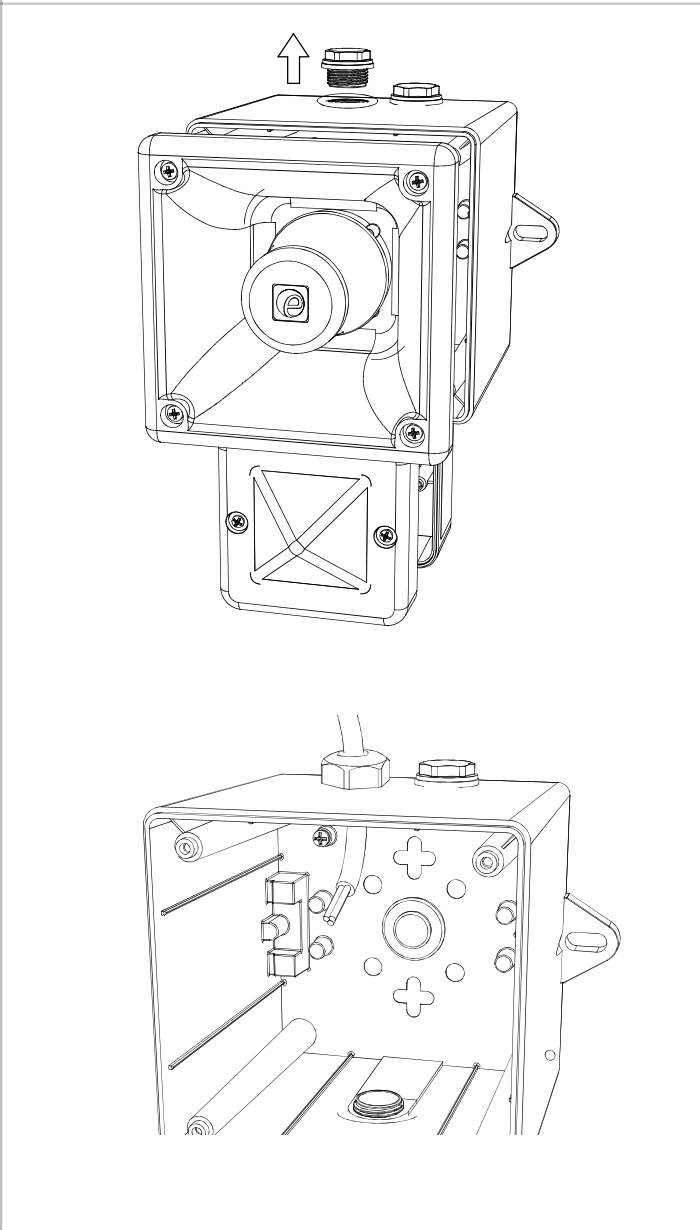
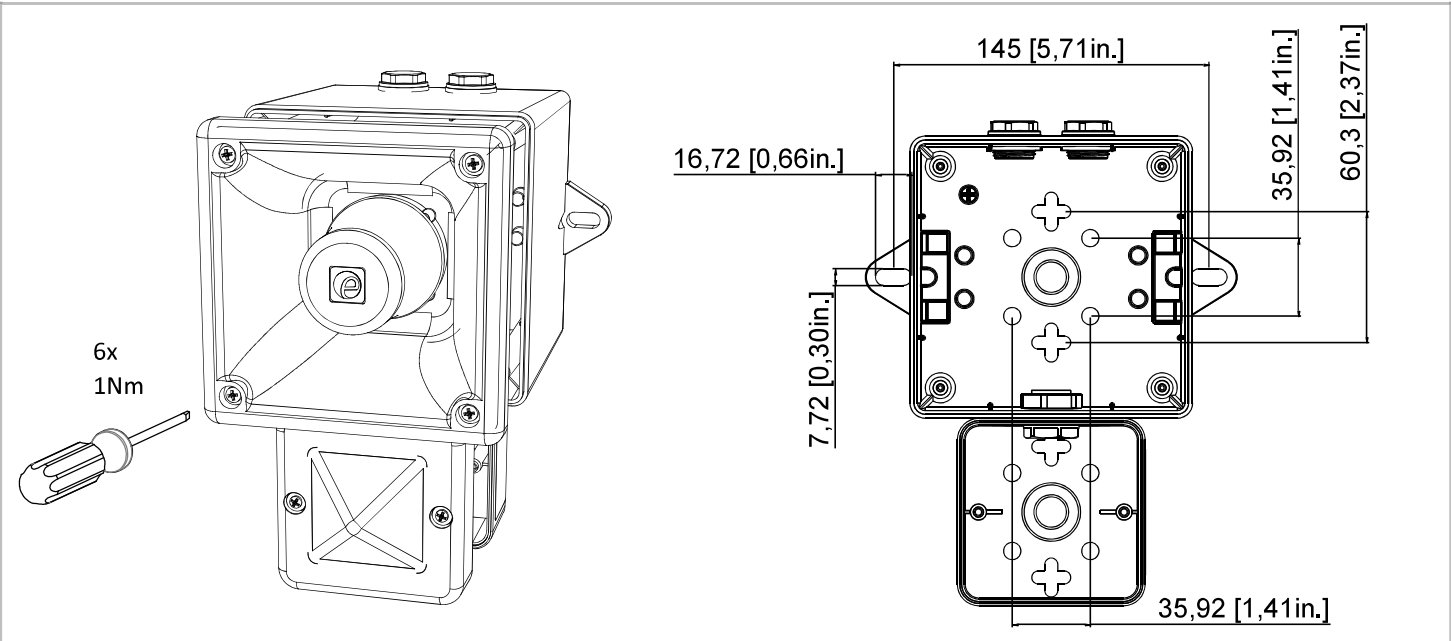

S1 - LED Flash Mode Settings (AC & DC)

The Flash Mode Dip Switch can be changed to set the desired flash pattern

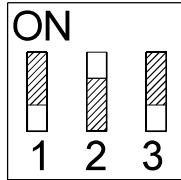

Flash Mode DIP Switch – Shown with 1-OFF, 2-ON, 3-OFF (0 1 0), This denotes Flash mode 1Hz. For further flash modes refer to table:

Switch	Flash Mode
0 0 0	Steady on
1 0 0	Blinking
0 1 0	Flashing 1Hz*
1 1 0	Flashing 1.5Hz*
0 0 1	Flashing - Double Strike
1 0 1	Flashing - Triple Strike
0 1 1	Flashing 2Hz*
1 1 1	Flashing - Temporal

- All models are approved for use as Audible Signal and Visual Appliance for use as General Signaling: UL464A & CSA C22.2 No 205-17
- Type 4 / 4X / 3R / 13, IP66
- -40°C to +66°C / -40°C to +151°F
 General Signaling Canada:
 AL105NHDC: -40°C to +55°C / -40°F to +131°F
 AL105NHAC: -40°C to +40°C / -40°F to +104°F
- To maintain Ingress Protection, cable entries must be fitted with suitably rated cable glands or stopping plugs
- EOL Monitoring (DC Only): End of Line Devices may be fitted between the +ve & -ve terminals of the PCBA. Please ensure that the device legs meet the wire size range stated for the connection terminals and are fitted correctly in order to avoid a short. Refer to the compatible control panel specification for EOL device values and ratings



Model	Nominal Voltage	Voltage Range	Nominal Operating Current*		Max Operating RMS#	
			Beacon	Sounder	Beacon	Sounder
AL105NHDC024	12V dc	10-14Vdc	79.5mA	17mA	168mA	125mA
	24V dc	16-33Vdc (Regulated)	87mA	33.5mA	183mA	
AL105NHDC048	48V dc	48-60Vdc	60mA	113mA	115mA	
AL105NHAC230	48V ac	48 - 260Vac 50/60Hz	60mA	42.5mA	166mA	42.5mA
	115V ac		34mA	25mA		
	230V ac		19mA	17mA		

*Nominal Voltage, 1Hz Flash Pattern & Tone 12; #Worst-case input voltage and worst case flash pattern

Stage 1 Set DIP SW 1 Tone No.	Tone Description	Tone Visual	Stage 1 & 2 DIP SW 1/2 Settings 1 2 3 4 5 6	Stage 3 Set DIP SW 1 (S3)	Stage 4 Set DIP SW 1 (S2 + S3)
1	1000Hz PFEER Toxic Gas		0 0 0 0 0	2	44
2	1200/500Hz @ 1Hz DIN /PFEER P.T.A.P.		1 0 0 0 0	3	44
3	1000Hz @ 0.5Hz(1s on, 1soff) PFEER Gen. Alarm		0 1 0 0 0 0	2	44
4	1.4KHz-1.6KHz 1s, 1.6KHz-1.4KHz 0.5s NF C 48-265		1 1 0 0 0 0	24	1
5	544Hz(100mS)/440Hz (400mS) NF S 32-001		0 0 1 0 0 0	19	1
6	1500/500Hz - (0.5s on , 0.5s off) x3 + 1s gap AS4428		1 0 1 0 0 0	44	1
7	500-1500Hz Sweeping 2 sec on 1 sec off AS4428		0 1 1 0 0 0	44	1
8	500/1200Hz @ 0.26Hz (3.3son, 0.5s off) Netherlands - NEN 2575		1 1 1 0 0 0	24	35
9	1000Hz (1s on, 1s off)x7 + (7s on, 1s off) IMO Code 1a		0 0 0 1 0 0	34	1
10	1000Hz (1s on, 1s off)x7 + (7s on, 1s off) IMO Code 1a		1 0 0 1 0 0	34	1
11	420Hz(0.5s on, 0.5s off)x3 + 1s gap ISO 8201 Temporal Pattern		0 1 0 1 0 0	1	8
12	1000Hz(0.5s on, 0.5s off)x3 + 1s gap ISO 8201 Temporal Pattern		1 1 0 1 0 0	1	8
13	422/775Hz - (0.85 on, 0.5 off) x3 + 1s gap NFPA - Temporal Coded		0 0 1 1 0 0	1	8
14	1000/2000Hz @ 1Hz Singapore		1 0 1 1 0 0	3	35
15	300Hz Continuous (f=300)		0 1 1 1 0 0	24	1
16	440Hz Continuous (f=440)		1 1 1 1 0 0	24	1
17	470Hz Continuous (f=470)		0 0 0 0 1 0	24	8
18	500Hz Continuous IMO code 2 (Low) (f=500)		1 0 0 0 1 0	24	8
19	554Hz Continuous (f=554)		0 1 0 0 1 0	24	8
20	660Hz Continuous (f=660)		1 1 0 0 1 0	24	35
21	800Hz IMO code 2 (High) (f=800)		0 0 1 0 1 0	24	35
22	1200Hz Continuous (f=1200)		1 0 1 0 1 0	24	35
23	2000Hz Continuous (f=2000)		0 1 1 0 1 0	3	35
24	2400Hz Continuous (f=2400)		1 1 1 0 1 0	20	35
25	440Hz @0.83Hz (50 cycles/minute) Intermittent (f=440, a=0.6, b=0.6)		0 0 0 1 1 0	44	8
26	470Hz @0.9Hz - 1.1s Intermittent (f=470, a=0.55, b=0.55)		1 0 0 1 1 0	44	8
27	470Hz @5Hz - (5 cycles/second) Intermittent (f=470, a=0.1, b=0.1)		0 1 0 1 1 0	44	8
28	544Hz @ 1.14Hz - 0.875s Intermittent (f=470, a=0.43, b=0.44)		1 1 0 1 1 0	24	8
29	655Hz @ 0.875Hz Intermittent (f=655, a=0.57, b=0.57)		0 0 1 1 1 0	24	8
30	660Hz @0.28Hz - 1.8sec on, 1.8sec off Intermittent (f=660, a=1.8, b=1.8)		1 0 1 1 1 0	24	8
31	660Hz @3.34Hz - 150mS on, 150mS off Intermittent (f=660, a=0.15, b=0.15)		0 1 1 1 1 0	24	8
32	745Hz @ 1Hz Intermittent (f=745, a=0.5, b=0.5)		1 1 1 1 1 0	24	8
33	800Hz - 0.25sec on, 1 sec off Intermittent (f=800, a=0.25, b=1)		0 0 0 0 0 1	24	8
34	800Hz @ 2Hz IMO code 3.a (High) Intermittent (f=800, a=0.25, b=0.25)		1 0 0 0 0 1	24	19
35	1000Hz @ 1Hz Intermittent (f=1000, a=0.5, b=0.5)		0 1 0 0 0 1	24	19
36	2400Hz @ 1Hz Intermittent (f=2400, a=0.5, b=0.5)		1 1 0 0 0 1	24	19
37	2900Hz @ 5Hz Intermittent (f=2900, a=0.1, b=0.1)		0 0 1 0 0 1	24	19
38	363/518Hz @ 1Hz Alternating (f=363, f1=518, a=0.1)		1 0 1 0 0 1	8	19
39	450/500Hz @ 2Hz Alternating (f=450, f1=500, a=0.25)		0 1 1 0 0 1	8	19
40	554/440Hz @ 1Hz Alternating (f=440, f1=554, a=0.5)		1 1 1 0 0 1	24	19
41	554/440Hz @ 0.625Hz Alternating (f=440, f1=554, a=0.8)		0 0 0 1 0 1	8	19
42	561/760Hz @0.83Hz (50 cycles/minute) Alternating (f=561, f1=760, a=0.6)		1 0 0 1 0 1	8	19
43	780/600Hz @ 0.96Hz Alternating (f=600, f1=780, a=0.52)		0 1 0 1 0 1	8	19
44	800/1000Hz @ 2Hz Alternating (f=800, f1=1000, a=0.25)		1 1 0 1 0 1	24	19
45	970/800Hz @ 2Hz Alternating (f=800, f1=970, a=0.25)		0 0 1 1 0 1	8	19
46	800/1000Hz @ 0.875Hz Alternating (f=800, f1=1000, a=0.57)		1 0 1 1 0 1	24	19
47	2400/2900Hz @ 2Hz Alternating (f=2400, f1=2900, a=0.25)		0 1 1 1 0 1	24	19
48	500/1200Hz @ 0.3Hz Sweeping (f=500, f1=1200, a=3.34)		1 1 1 1 0 1	24	12
49	560/1055Hz @ 0.18Hz Sweeping (f=560, f1=1055, a=5.47)		0 0 0 0 1 1	24	12
50	560/1055Hz @ 3.3Hz Sweeping (f=560, f1=1055, a=0.3)		1 0 0 0 1 1	24	12
51	600/1250Hz @ 0.125Hz Sweeping (f=600, f1=1250, a=8)		0 1 0 0 1 1	24	12
52	660/1200Hz @ 1Hz Sweeping (f=660, f1=1200, a=1)		1 1 0 0 1 1	24	12
53	800/1000Hz @ 1Hz Sweeping (f=800, f1=1000, a=1)		0 0 1 0 1 1	24	12
54	800/1000Hz @ 7Hz Sweeping (f=800, f1=1000, a=0.14)		1 0 1 0 1 1	24	12
55	800/1000Hz @ 50Hz Sweeping (f=800, f1=1000, a=0.02)		0 1 1 0 1 1	24	12
56	2400/2900Hz @ 7Hz Sweeping (f=2400, f1=2900, a=0.14)		1 1 1 0 1 1	24	12
57	2400/2900Hz @ 1Hz Sweeping (f=2400, f1=2900, a=1)		0 0 0 1 1 1	24	12
58	2400/2900Hz @ 50Hz Sweeping (f=2400, f1=2900, a=0.02)		1 0 0 1 1 1	24	12
59	2500/3000Hz @ 2Hz Sweeping (f=2500, f1=3000, a=0.5)		0 1 0 1 1 1	24	12
60	2500/3000Hz @ 7.7Hz Sweeping (f=2500, f1=3000, a=0.13)		1 1 0 1 1 1	24	12
61	800Hz Motor Siren (f=800, a=1.6)		0 0 1 1 1 1	24	12
62	1200Hz Motor Siren (f=1200, a=2)		1 0 1 1 1 1	24	12
63	2400Hz Motor Siren (f=2400, a=1.7)		0 1 1 1 1 1	24	12
64	Simulated Bell		1 1 1 1 1 1	21	12

FIRE INSTRUCTION & SERVICE MANUAL

AL105NH Range AlertAlight Combined Sounder LED Beacons

UL464 / CAN/ULC-S525 & UL1638 / CAN/ULC-S526

Model: AL105NHDC



Attention: Installation must be carried out by an electrician in compliance with the National Electrical Code, NFPA 70, and the National Fire Alarm Signaling Code, NFPA 72 or CSA 22.1 Canadian Electrical Code, Part I, Safety Standard for Electrical Installations, Section 32. / L'installation doit exclusivement être réalisée par du personnel qualifié, conformément au code national d'électricité américain, NFPA 70, et le code national d'alarme incendie et de signalisation NFPA 72 ou CSA 22.1 Code canadien de l'électricité, première partie, norme de sécurité relative aux installations électriques, Section 32



Attention: Disconnect from power source before installation or service to prevent electric shock / Débranchez-le de la source d'alimentation avant l'installation ou l'entretien pour éviter tout choc électrique.



Attention: Do not paint / Ne pas Peinturer

- -40°C to +66°C / -40°F to +151°F
- Units can be mounted using the 2-off ø7mm holes in the mounting lugs or through the back of the housing using the supplied gasket seal.
- AL105NHDC024 is approved for use as an Audible & Visual signal appliance for fire alarm use – Private Mode. (UL464 & CAN/ULC-S525 & UL1638).
- AL105NHDC024 produces a minimum sound pressure level of US: 79.97dB(A); CA: 91.2dB(A) at 10 feet, (figures @ worst case 10Vdc).
- AL105NHDC024 produces a minimum sound pressure level of US: 88.8dB(A); CA: 99.8dB(A) at 10 feet (@ 24Vdc)
- For Fire Alarm applications, the Sounder Volume must be at the highest setting, (see volume control section). For fire alarm use, Tone 12 as shown below must be selected:

Stage 1 Set DIP SW 1 Tone No.	Tone Description	Tone Visual	Stage 1 & 2 DIP SW 1/2 Settings 1 2 3 4 5 6	Stage 3 Set DIP SW 1 (S3)	Stage 4 Set DIP SW 1 (S2 + S3)
12	1000Hz(0.5s on, 0.5s off)x3 + 1s gap ISO 8201 Temporal Pattern		1 1 0 1 0 0	1	8

- For private mode fire alarm use, the beacons must only be fitted with clear plastic lens covers and must be set to one of the certified flash patterns of 1Hz, 1.5Hz or 2Hz.. Flash Pulse 196ms.
- For light output ratings see below:

On-axis light output rating per UL1638

Model	Intensity (cd) at 1Hz flash rate	Intensity (cd) at 1.5Hz flash rate	Intensity (cd) at 2Hz flash rate
AL105NHDC024 (12Vdc Mode)	5.9	5.97	6.35
AL105NDC024 (24Vdc Mode)	11.65	12.32	12.38

- Connection Terminals: Pluggable
AC: 1.0 - 2.5mm² / AWG18 - AWG12
DC: 0.2 - 2.5mm² / AWG24 - AWG12
- Terminal Tightening torque 0.4Nm
- To maintain Ingress Protection, cable entries must be fitted with suitably rated cable glands or stopping plugs
- Units can be located indoor or outdoor wet use, wall or ceiling mounted and there are no limitations on orientation
- Factory finishes are not intended to be modified

Surge current ratings for use in fire alarm systems

Model	Nominal Voltage	Voltage Range	Flash Rate	Initial Peak (mA)		Initial RMS (mA)	
				Beacon	Sounder	Beacon	Sounder
AL105NHDC024	12Vdc	10 to 14Vdc	1 Hz	202	298	172	56.4
			1.5Hz	216		172	
			2Hz	224		172	
	24Vdc	16 to 33Vdc (Regulated)	1 Hz	950		204.3	
			1.5Hz	968.5		206.7	
			2Hz	969		205.2	



AL105NHDC024 Sounder Directional Characteristics for Canadian Fire CAN/ULC-S525 at 10 feet

Horizontal Axis				Vertical Axis			
Angle	OSPL	Angle	OSPL	Angle	OSPL	Angle	OSPL
Ref.90°	101 dB(A)	Ref. 90°	101 dB(A)	Ref. 90°	100.9 dB(A)	Ref. 90°	100.9 dB(A)
113°	-3 dB(A)	67°	-3 dB(A)	113.5°	-3 dB(A)	64°	-3 dB(A)
125°/147°	-6 dB(A)	52°	-6 dB(A)	130°/148°	-6 dB(A)	47°	-6 dB(A)
180°	86.1 dB(A)	0°	86.1 dB(A)	180°	86.5 dB(A)	0°	86.1 dB(A)

AL105NHDC024 Beacon PCBA (24VDC Mode – Default Setting)

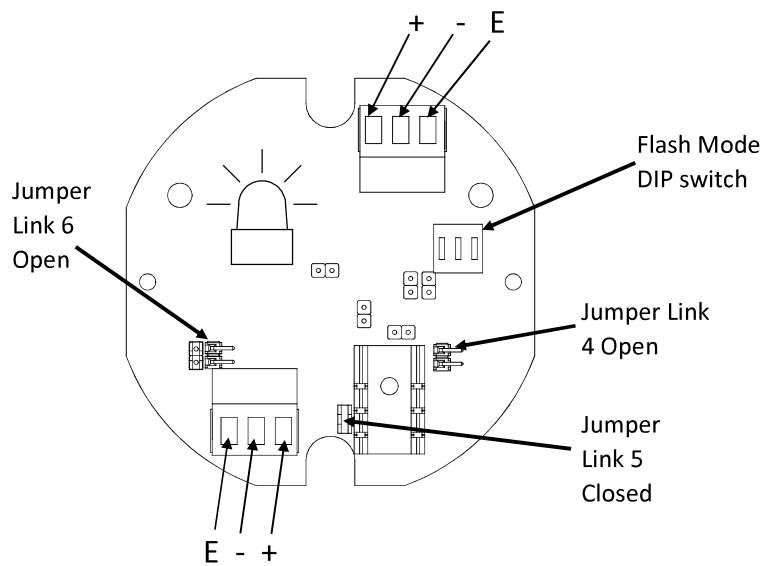

AL105NHDC024 Sounder

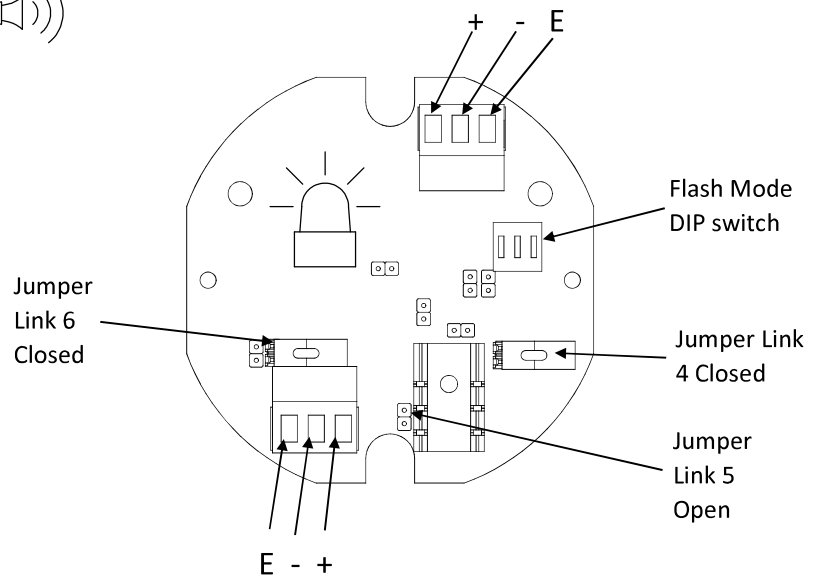
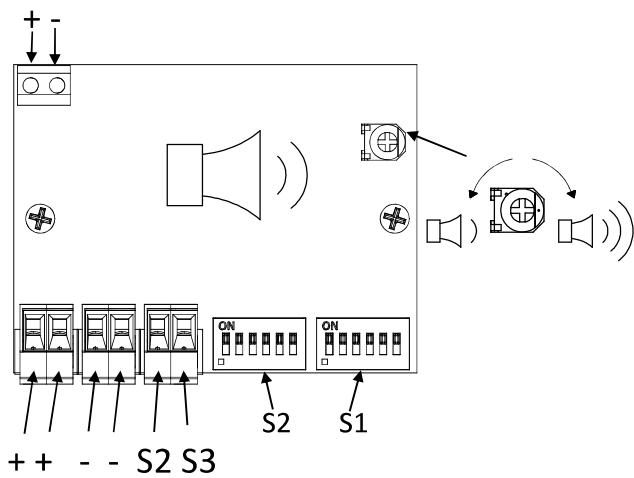

AL105NHDC024 Beacon PCBA (12VDC Mode – Customer to Set)

Jumper Setting	Jumper Link 4	Jumper Link 5	Jumper Link 6
24VDC Mode (Default)	Open	Closed	Open
12VDC Mode (Customer Set)	Closed	Open	Closed

1	2	3	4	5	6	7	8	9	10
<p>OPTIONAL LINE MONITORING RESISTOR, CUSTOMER SUPPLIED, RECOMMENDED MINIMUM VALUES: 14V MAX SYSTEM = 120Ω MIN, 2W MIN OR 1KΩ MIN, 0.5W MIN 28V MAX SYSTEM = 470Ω MIN, 2W MIN OR 2.4KΩ MIN, 0.5W MIN</p>									
<p>ISSUE MOD No. REASON - INITIAL - DATE A</p>									
<p>INTRODUCTION RSR - 16/04/2021</p>									

<p align="center">Independent Sounder & Beacon Activation (Remove Link Wires)</p>											
<p>Single Stage Configuration Line Monitoring</p>		<p>Config.: 5a</p>		<p>Two Stage Configuration Common Negative</p>		<p>Config.: 5b</p>		<p>Three/Four Stage Configuration Common Negative</p>		<p>Config.: 5c</p>	
<p>Stage 1: Apply Power to Stage 1 +ve & Stage 1 -ve</p>		<p>Stage 1: Apply Power to Stage 1 +ve & Common -ve Stage 2: Apply Power to Stage 2 +ve & Common -ve</p>		<p>Stage 1: Apply Power to Stage 1 +ve & Common -ve Stage 2: Apply Power to Stage 2 +ve & Common -ve</p>		<p>Stage 1: Apply Power to Stage 1 +ve & Common -ve Stage 2: Apply Power to Stage 2 +ve & Common -ve Stage 3: Apply Power to Stage 3 +ve & Common -ve Stage 4: Apply Power to Stage 2 +ve, Stage 3 +ve & Common -ve</p>					

<p>DRAWING TO BS8888:2000 GEOMETRIC TOLERANCES TO ISO1101:1983 LINEAR DIMENSIONAL TOLS ANGULAR DIMENSIONAL TOLS</p>		<p>DRAWN R.S. RAIT</p>	<p>DATE 16/03/2021</p>	<p>SURFACE FINISH MATERIAL</p>	<p>WEIGHT (kg)</p>	<p>THIS DRAWING AND ANY INFORMATION OR DESCRIPTIVE MATTER THEREIN IS COMMUNICATED IN CONFIDENCE AND SYSTEMS LTD. NEITHER THE WHOLE OR ANY EXTRACT MAY BE DISCLOSED, LOANED, COPIED OR USED FOR MANUFACTURING OR TENDERING PURPOSES WITHOUT THEIR WRITTEN CONSENT.</p>		<p>EUROPEAN SAFETY SYSTEMS LTD MARKET HOUSE LONDON W3 7QH WWW.ESS.COM</p>		<p>ALL DIMENSIONS IN MM IF IN DOUBT, ASK - DO NOT SCALE</p>		<p>A3</p>
<p>STANDARDS ALERTALARM RANGE</p>		<p>CHECKED B. ISARD</p>	<p>DATE 16/03/2021</p>	<p>ALTERNATIVE MATERIAL</p>	<p>AS PER LATEST DATE OF ISSUE SHOWN ABOVE</p>		<p>TITLE AL100H, AL105NH & DL105H DC COMBINED SOUNDER & LED WIRING DIAGRAMS</p>		<p>SCALE NTS</p>	<p>SHEET 2 OF 2</p>	<p>DRAWING NUMBER D218-06-251</p>	

Linked Sounder & Beacon Activation (Default)

Single Stage Configuration
 Stage 1: Apply Power to Stage 1 Live & Stage 1 Neutral

Two/Three Stage Sounder Configuration
 Stage 1: Apply Power to Live & Neutral
 Stage 2: Apply Power to Live & Neutral & connect Stage 2 to Live
 Stage 3: Apply Power to Live & Neutral & connect Stage 3 to Live

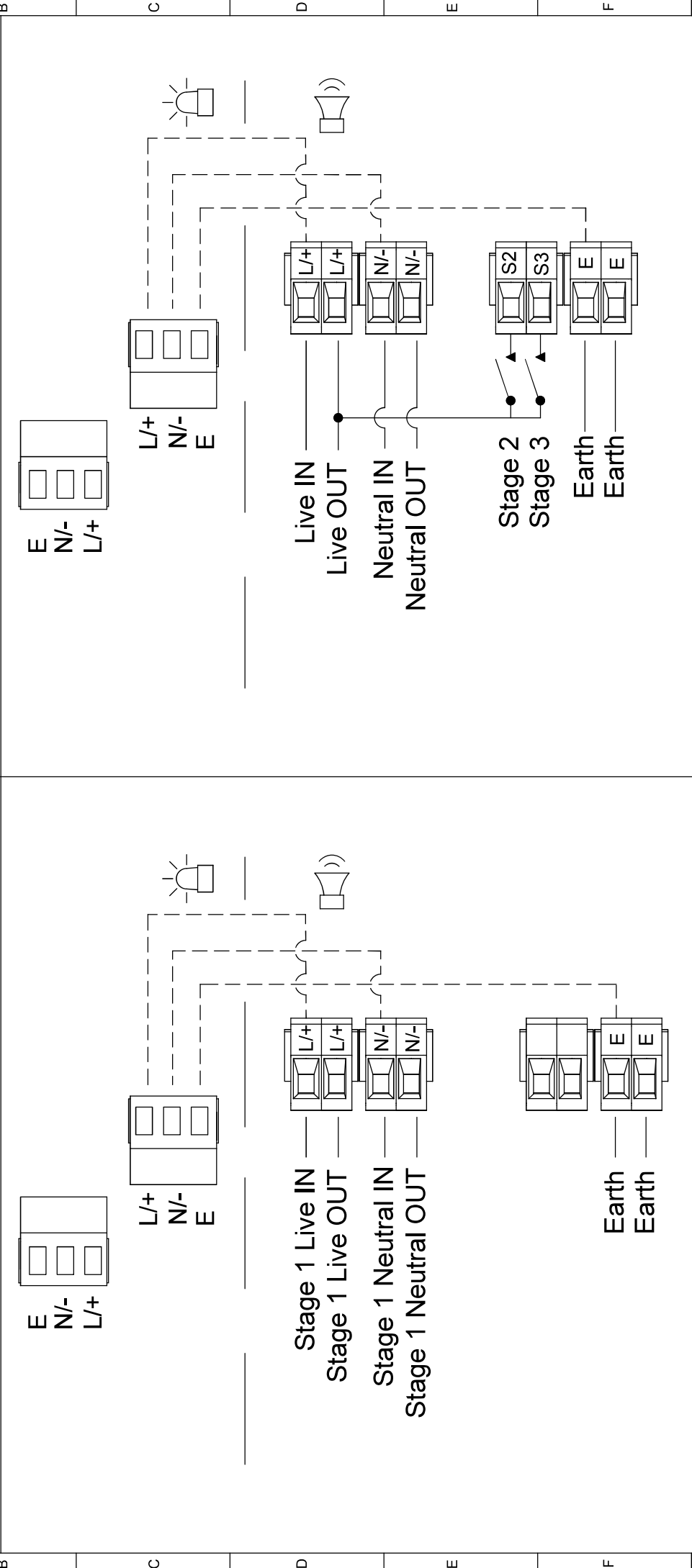

DRAWING TO BS8888:2000 GEOMETRIC TOLERANCES TO ISO1101:1983 LINEAR DIMENSIONAL TOLS ANGULAR DIMENSIONAL TOLS	DRAWN	DATE	SURFACE FINISH	WEIGHT (kg)					
	R.S.RAIT	16/03/2021	MATERIAL						
STANDARDS ALERTALARM RANGE	CHECKED	DATE	ALTERNATIVE MATERIAL		THIS DRAWING AND ANY INFORMATION OR DESCRIPTIVE MATTER THEREIN IS COMMUNICATED IN CONFIDENCE AND SYSTEMS LTD. NEITHER THE WHOLE OR ANY EXTRACT MAY BE DISCLOSED, LOANED, COPIED OR USED FOR MANUFACTURING OR TENDERING PURPOSES WITHOUT THEIR WRITTEN CONSENT. © EUROPEAN SAFETY SYSTEMS LTD. AS PER LATEST DATE OF ISSUE SHOWN ABOVE				
	B.ISARD	16/03/2021							
	APPROVED	DATE			2S EUROPEAN SAFETY SYSTEMS LTD MANAGER HOUSE LONDON W3 7QH WWW.E2S.COM				
	R.N.POTTS	16/03/2021			ALL DIMENSIONS IN MM IF IN DOUBT, ASK - DO NOT SCALE				
					TITLE AL100H, AL105NH & DL105H AC COMBINED SOUNDER & LED WIRING DIAGRAMS				
					SCALE NTS SHEET 1 OF 2 DRAWING NUMBER D218-06-255				

1	2	3	4	5	6	7	8	9	10
<p>--- WIRING LINKING BEACON & SOUNDER FACTORY FITTED</p>		<p>SWITCHES FOR STAGE OPERATION CUSTOMER SUPPLIED</p>		<p>ISSUE A</p>		<p>MOD No</p>		<p>REASON - INITIAL - DATE</p>	
				<p>INTRODUCTION RSR - 16/04/2021</p>					

Independent Sounder & Beacon Activation (Remove Link Wires)

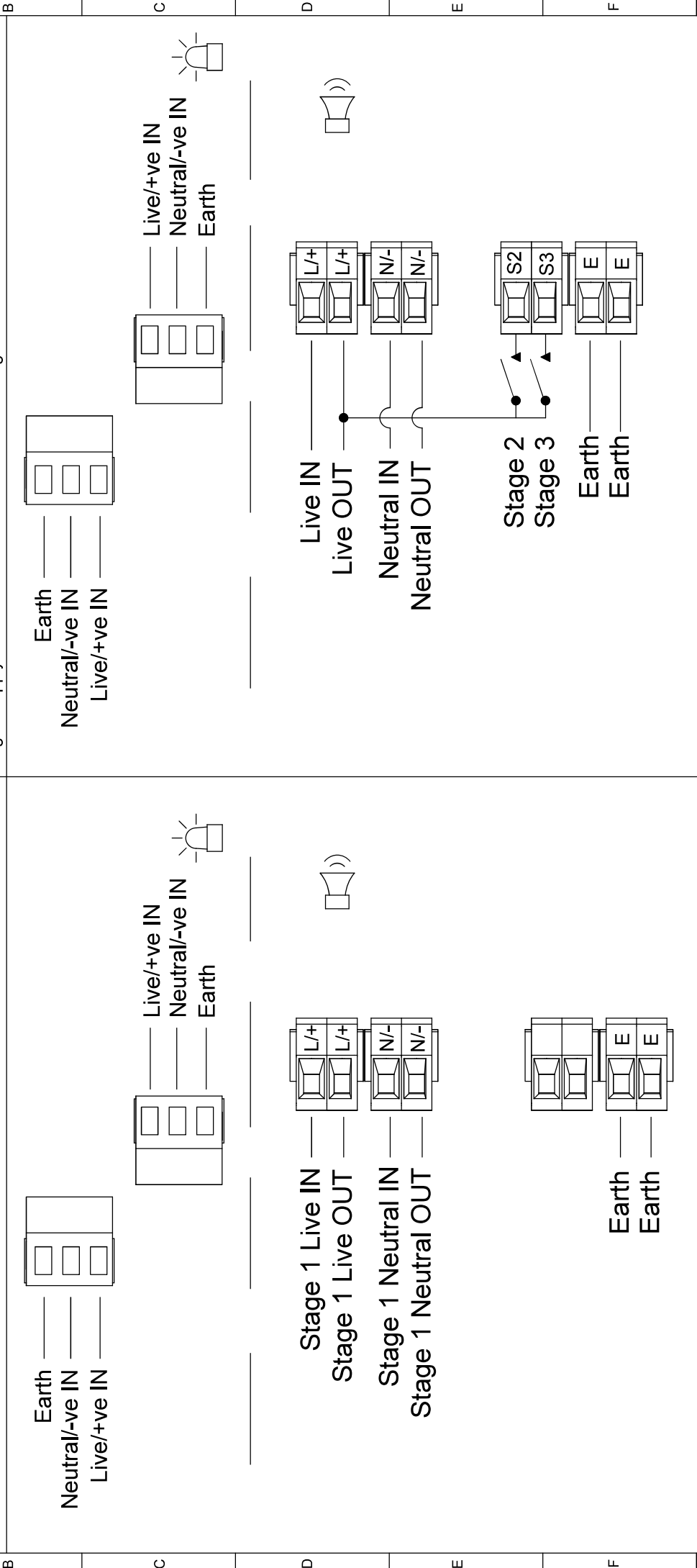

<p>DRAWING TO BS8888:2000 GEOMETRIC TOLERANCES TO ISO1101:1983 LINEAR DIMENSIONAL TOLS ANGULAR DIMENSIONAL TOLS</p>	<p>DRAWN R.S. RAIT</p>	<p>DATE 16/03/2021</p>	<p>SURFACE FINISH</p>	<p>WEIGHT (kg)</p>	<p>THIS DRAWING AND ANY INFORMATION OR DESCRIPTIVE MATTER THEREIN IS COMMUNICATED IN CONFIDENCE AND SYSTEMS LTD. NEITHER THE WHOLE OR ANY EXTRACT MAY BE DISCLOSED, LOANED, COPIED OR USED FOR MANUFACTURING OR TENDERING PURPOSES WITHOUT THEIR WRITTEN CONSENT.</p> <p align="right">© EUROPEAN SAFETY SYSTEMS LTD. AS PER LATEST DATE OF ISSUE SHOWN ABOVE</p>	<p>EUROPEAN SAFETY SYSTEMS LTD MANAGER HOUSE LONDON W3 7QH WWW.ESS.COM</p>	<p>ALL DIMENSIONS IN MM IF IN DOUBT, ASK - DO NOT SCALE</p>	<p>IF IN DOUBT, ASK - DO NOT SCALE</p>	<p>A3</p>
	<p>CHECKED B. ISARD</p>	<p>DATE 16/03/2021</p>	<p>MATERIAL</p>	<p>ALTERNATIVE MATERIAL</p>			<p>TITLE AL100H, AL105NH & DL105H AC COMBINED SOUNDER & LED WIRING DIAGRAMS</p>	<p>SCALE NTS</p>	<p>SHEET 2 OF 2</p>
<p>STANDARDS ALERTALARM RANGE</p>	<p>APPROVED R.N.POTTS</p>	<p>DATE 16/03/2021</p>							