

# DC CONFIGURATIONS

**E2S PART NO**  
**D2x[C3][N1][XX][XX][XX][S1]**  
**D2x[C3][N2][XX][XX][XX][S1]**

**DESCRIPTION**  
**D2xC3 STACK - 3 BEACONS & ALARM HORN**

**DATA REFERENCE**  
**1-35-020**

Note: Alternative wiring configurations may be available on request - contact E2S sales

ISSUE	MOD No.	REASON - INITIAL - DATE
1		INTRODUCTION DAH - 15-08-2019
2		B1 NOW WIRED INTO TB DAH - 01/04/2020
3		CONFIG 1-4 ADDED. SH2 ADDED DAH - 20/04/2023

## CONFIG. 1 (DEFAULT)

DC VOLTAGE SUPPLY  
 COMMON NEGATIVE CONNECTION TO ALL SIGNALS  
 POSITIVE STAGE SWITCHING FOR ALARM HORN SOUNDER

## CONFIG. 3

DC VOLTAGE SUPPLY  
 COMMON NEGATIVE CONNECTION TO ALL SIGNALS  
 NEGATIVE STAGE SWITCHING FOR ALARM HORN SOUNDER

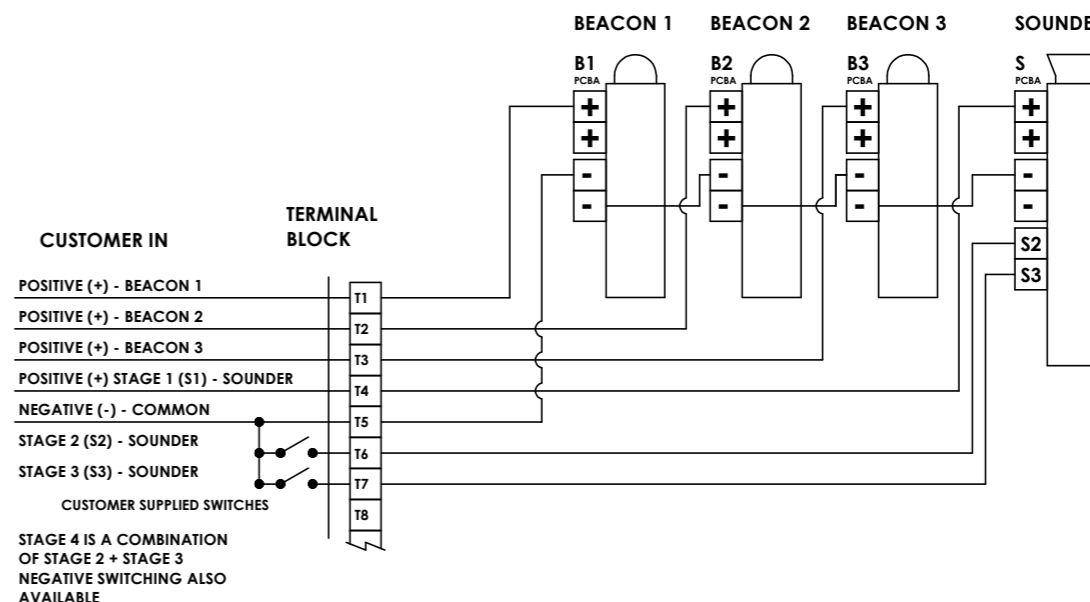
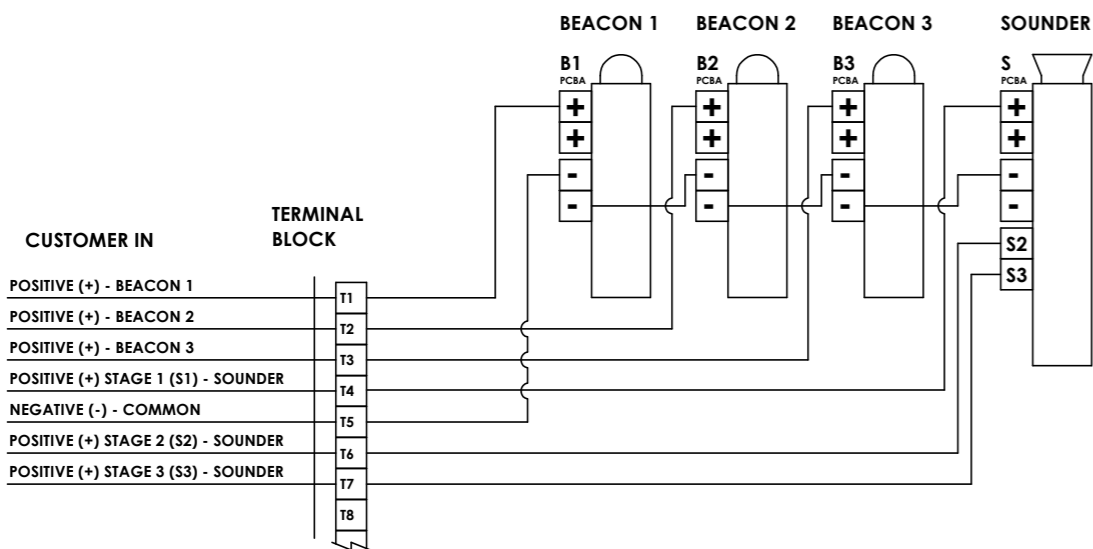

## CONFIG. 2

DC VOLTAGE SUPPLY  
 INDEPENDENT CONNECTIONS TO ALL SIGNALS  
 POSITIVE STAGE SWITCHING FOR ALARM HORN SOUNDER

## CONFIG. 4

DC VOLTAGE SUPPLY  
 INDEPENDENT CONNECTIONS TO ALL SIGNALS  
 NEGATIVE STAGE SWITCHING FOR ALARM HORN SOUNDER

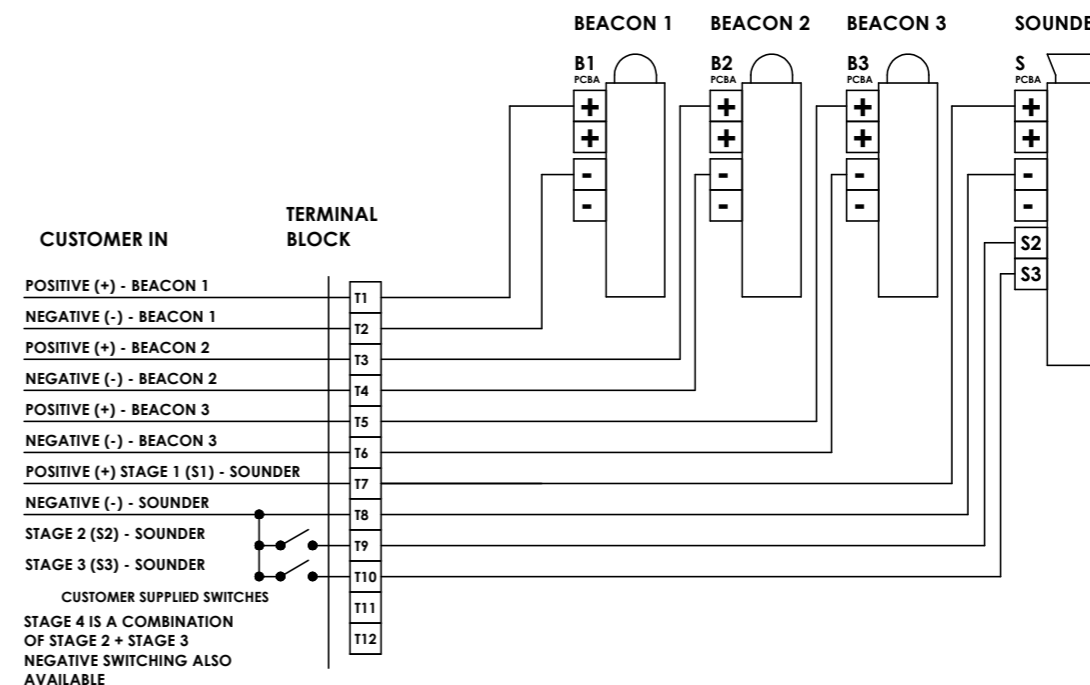
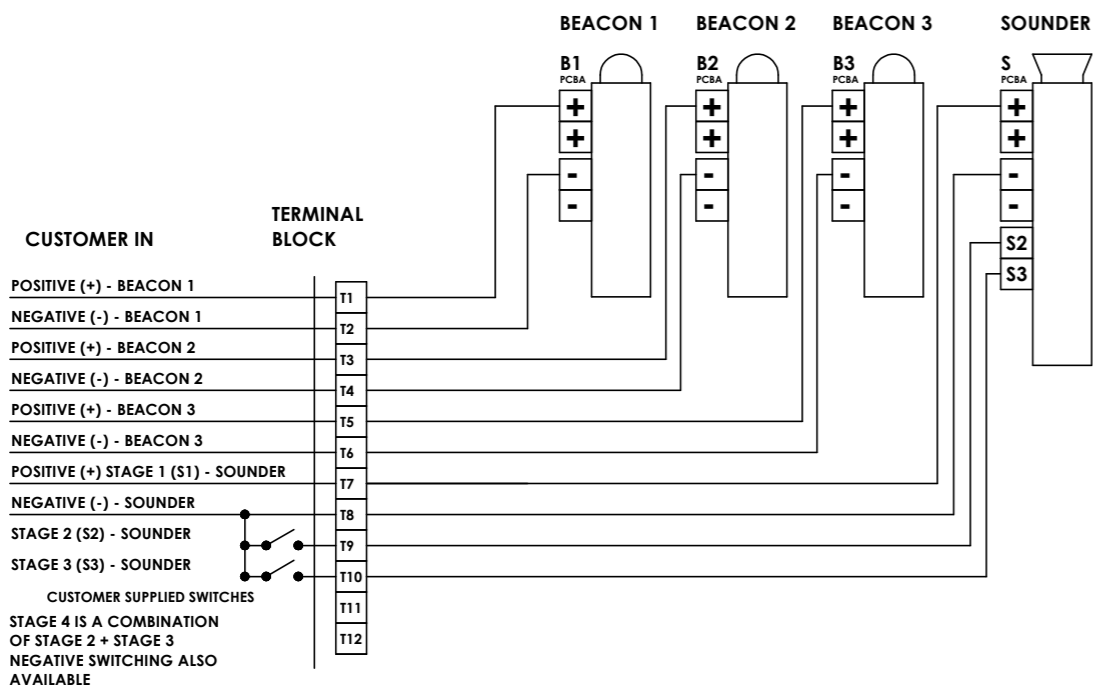

DRAWING TO BS8888:2000  
 GEOMETRIC TOLERANCES TO ISO1101:1983  
 LINEAR DIMENSIONAL TOLS  
 ANGULAR DIMENSIONAL TOLS

DRAWN	DATE
D.HOWGILL	15-08-2019
CHECKED	DATE
R.N.POTTS	15-08-2019
APPROVED	DATE
R.N.POTTS	15-08-2019

SURFACE FINISH	WEIGHT (Kg)
FINISH	
MATERIAL	
ALTERNATIVE MATERIAL	

THIS DRAWING AND ANY INFORMATION OR DESCRIPTIVE MATTER THEREIN IS COMMUNICATED IN CONFIDENCE AND IS THE COPYRIGHT PROPERTY OF EUROPEAN SAFETY SYSTEMS LTD. NEITHER THE WHOLE OR ANY EXTRACT MAY BE DISCLOSED, LOANED, COPIED OR USED FOR MANUFACTURING OR TENDERING PURPOSES WITHOUT THEIR WRITTEN CONSENT.

EUROPEAN SAFETY SYSTEMS LTD.  
 AS PER LATEST DATE OF ISSUE SHOWN ABOVE

**e2s**  
 warning signals  
 EUROPEAN SAFETY SYSTEMS LTD  
 IMPRESS HOUSE  
 MANSELL ROAD  
 ACTON  
 LONDON W3 7QH  
 WWW.E2S.COM

ALL DIMENSIONS IN MM  
 IF IN DOUBT, ASK -  
 DO NOT SCALE

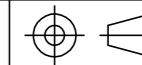

**A2**

TITLE **D2xC3 STACK - 3 BEACONS & ALARM HORN WIRING SCHEMATIC**

SCALE  
 NTS

SHEET  
 1 OF 3

DRAWING NUMBER  
 D215-06-145

# DC CONFIGURATIONS

ISSUE	MOD No.	REASON - INITIAL - DATE
1		SEE SH1
2		SEE SH1
3		SEE SH1

## CONFIG. 5

DC VOLTAGE SUPPLY  
 BEACON 1 / STAGE 1 LINKED ; BEACON 2 / STAGE 2 LINKED ; BEACON 3 / STAGE 3 LINKED  
 POSITIVE STAGE SWITCHING FOR ALARM HORN SOUNDER WITH END OF LINE MONITORING (3 STAGES)

## ENTRY TERMINALS

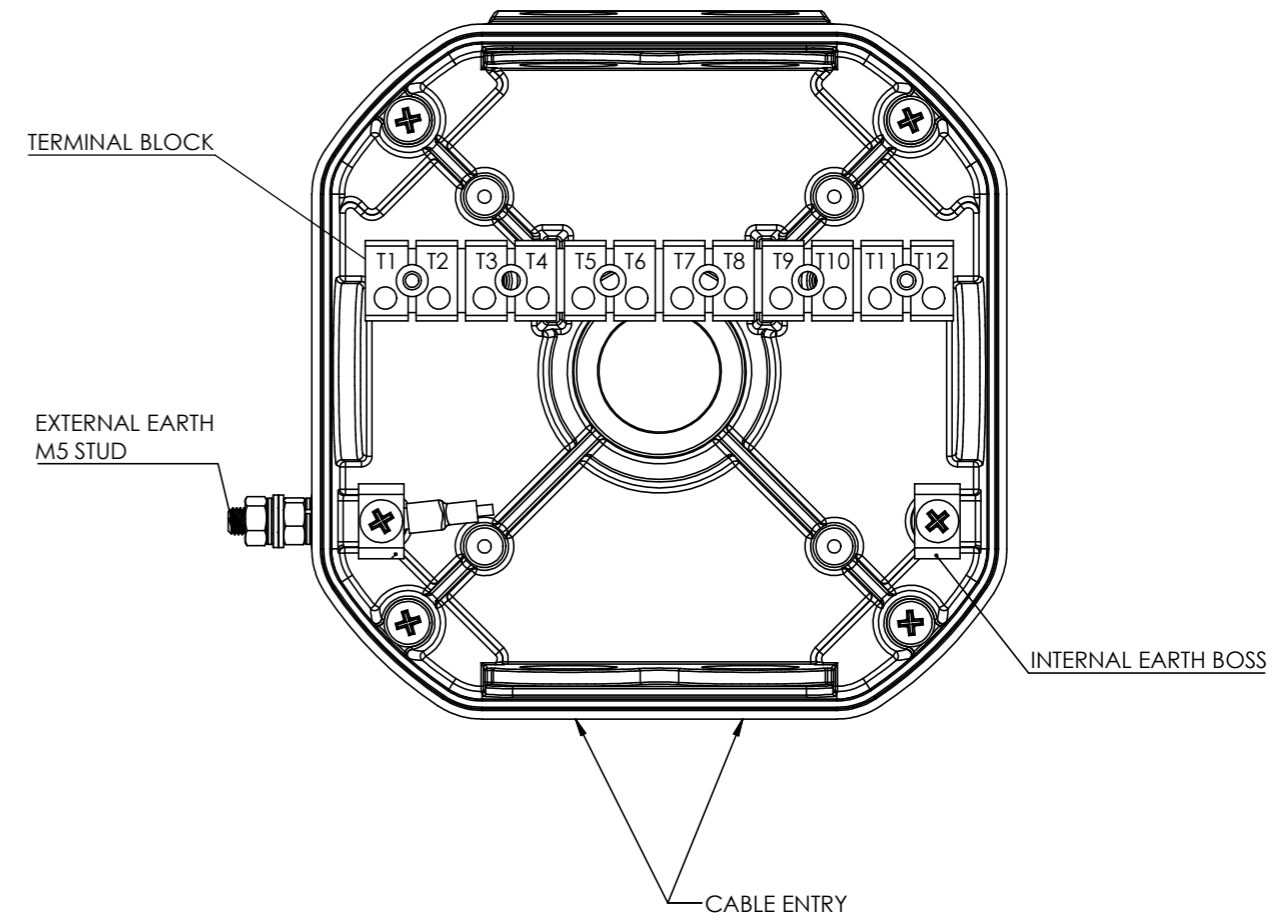
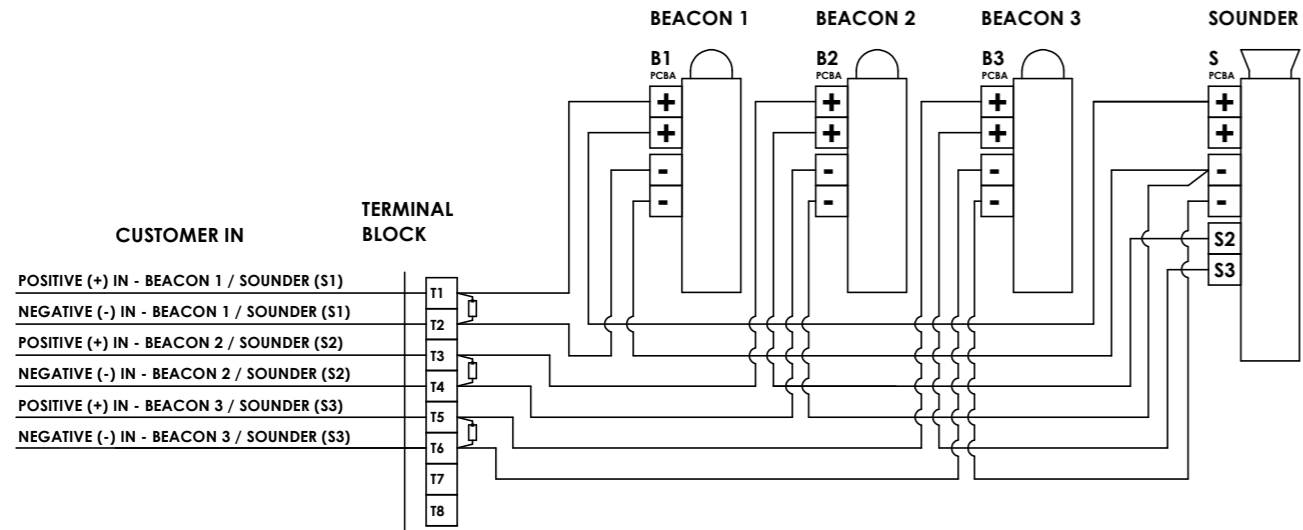

## CONFIG. 6

DC VOLTAGE SUPPLY  
 INDEPENDENT CONNECTIONS TO ALL SIGNALS  
 END OF LINE MONITORING ON ALL SIGNALS

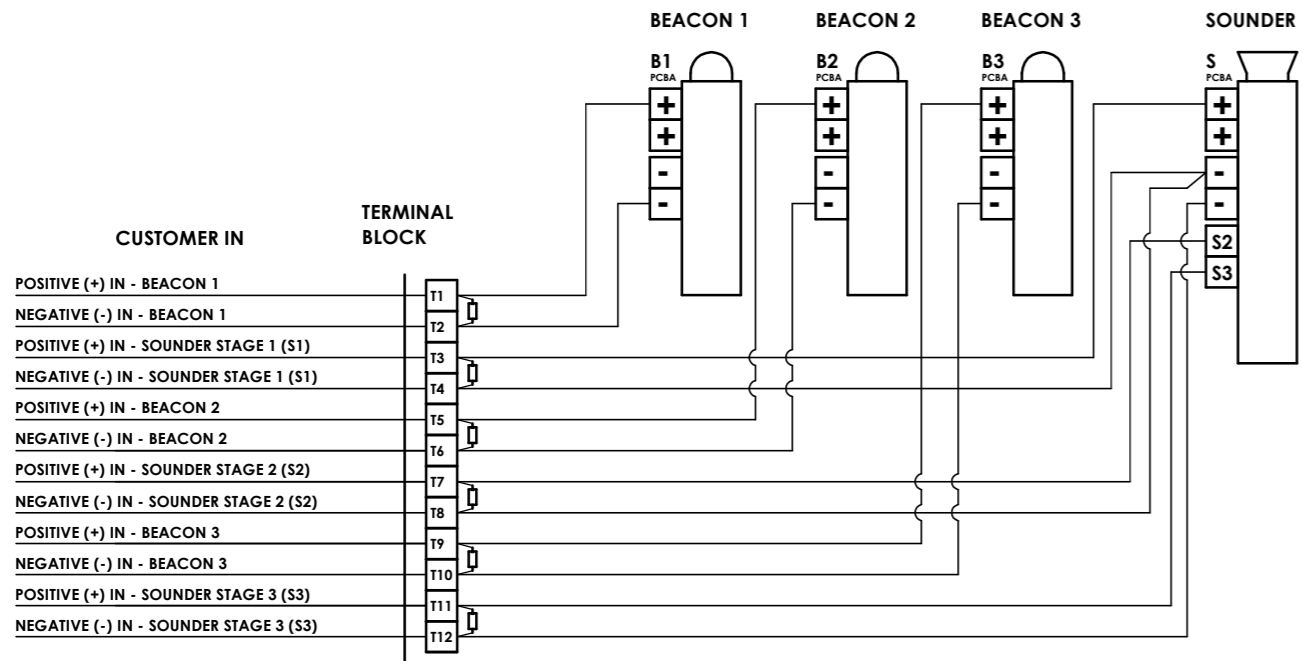

DRAWING TO BS8888:2000 GEOMETRIC TOLERANCES TO ISO1101:1983 LINEAR DIMENSIONAL TOLS ANGULAR DIMENSIONAL TOLS	DRAWN D.HOWGILL DATE 15-08-2019	SURFACE FINISH FINISH	WEIGHT (kg)	THIS DRAWING AND ANY INFORMATION OR DESCRIPTIVE MATTER THEREIN IS COMMUNICATED IN CONFIDENCE AND IS THE COPYRIGHT PROPERTY OF EUROPEAN SAFETY SYSTEMS LTD. NEITHER THE WHOLE OR ANY EXTRACT MAY BE DISCLOSED, LOANED, COPIED OR USED FOR MANUFACTURING OR TENDERING PURPOSES WITHOUT THEIR WRITTEN CONSENT.	 EUROPEAN SAFETY SYSTEMS LTD IMPRESS HOUSE MANSELL ROAD ACTON LONDON W3 7QH WWW.E2S.COM	ALL DIMENSIONS IN MM IF IN DOUBT, ASK - DO NOT SCALE	 A2	
	CHECKED R.N.POTTS DATE 15-08-2019					MATERIAL		TITLE D2xC3 STACK - 3 BEACONS & ALARM HORN WIRING SCHEMATIC
	APPROVED R.N.POTTS DATE 15-08-2019					ALTERNATIVE MATERIAL		SCALE NTS

# AC CONFIGURATIONS

ISSUE	MOD No.	REASON - INITIAL - DATE
1		SEE SH1
2		SEE SH1
3		SEE SH1

## CONFIG. 1 (DEFAULT)

- AC VOLTAGE SUPPLY
- COMMON NEUTRAL CONNECTION TO ALL SIGNALS
- COMMON STAGE SWITCHING FOR ALARM HORN SOUNDER

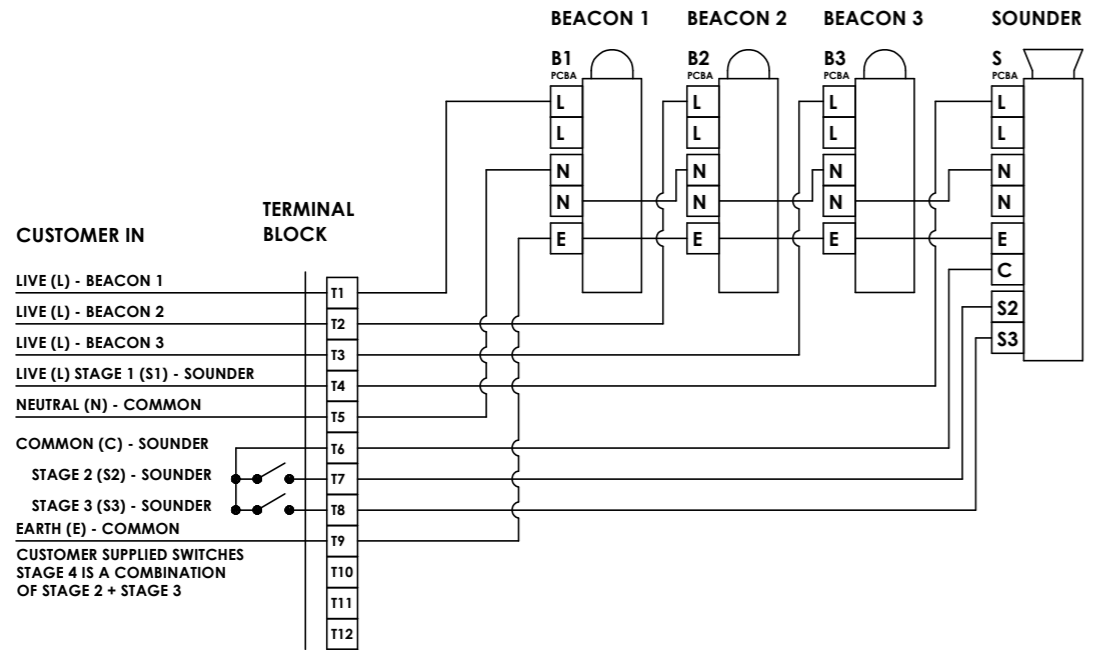

## CONFIG. 2

- AC VOLTAGE SUPPLY
- INDEPENDENT CONNECTIONS TO ALL SIGNALS
- COMMON STAGE SWITCHING FOR ALARM HORN SOUNDER

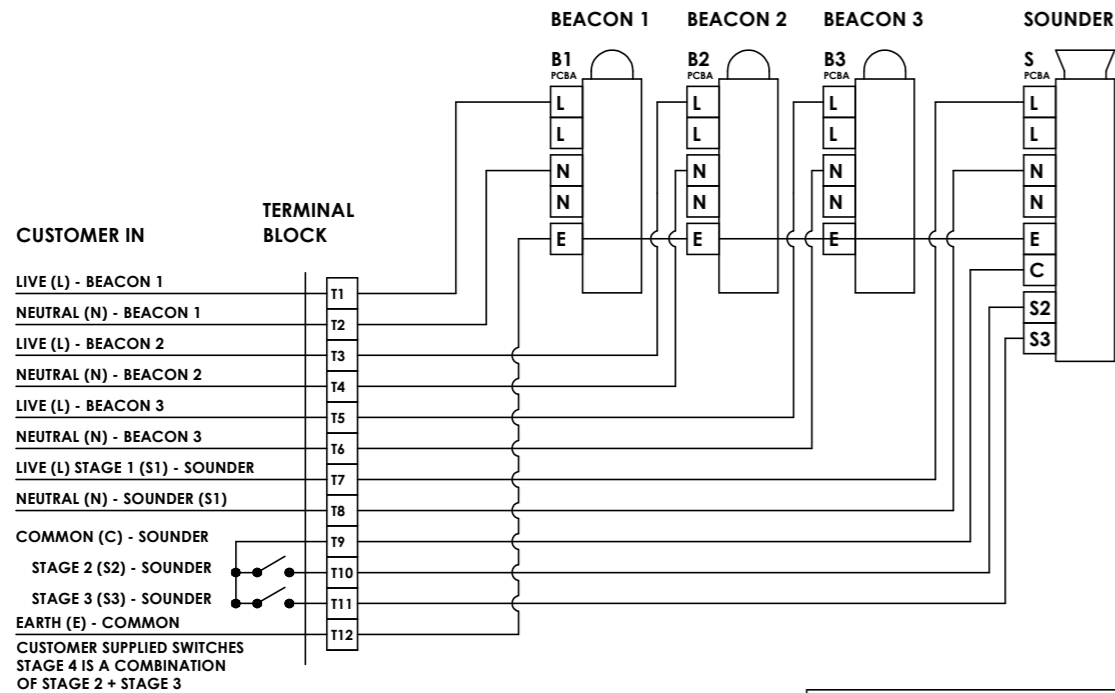

DRAWING TO BS8888:2000  
GEOMETRIC TOLERANCES TO ISO1101:1983  
LINEAR DIMENSIONAL TOLS  
ANGULAR DIMENSIONAL TOLS

DRAWN	DATE
D.HOWGILL	15-08-2019
CHECKED	DATE
R.N.POTTS	15-08-2019
APPROVED	DATE
R.N.POTTS	15-08-2019

SURFACE FINISH	WEIGHT (kg)
FINISH	
MATERIAL	
ALTERNATIVE MATERIAL	

THIS DRAWING AND ANY INFORMATION OR DESCRIPTIVE MATTER THEREIN IS COMMUNICATED IN CONFIDENCE AND IS THE COPYRIGHT PROPERTY OF EUROPEAN SAFETY SYSTEMS LTD. NEITHER THE WHOLE OR ANY EXTRACT MAY BE DISCLOSED, LOANED, COPIED OR USED FOR MANUFACTURING OR TENDERING PURPOSES WITHOUT THEIR WRITTEN CONSENT.

EUROPEAN SAFETY SYSTEMS LTD.  
AS PER LATEST DATE OF ISSUE SHOWN ABOVE

**e2s**  
warning signals

EUROPEAN SAFETY SYSTEMS LTD  
IMPRESS HOUSE  
MANSELL ROAD  
ACTON  
LONDON W3 7QH  
WWW.E2S.COM

ALL DIMENSIONS IN MM IF IN DOUBT, ASK - DO NOT SCALE			<b>A2</b>
TITLE D2xC3 STACK - 3 BEACONS & ALARM HORN WIRING SCHEMATIC			
SCALE NTS	SHEET 3 OF 3	DRAWING NUMBER D215-06-145	