

# INSTRUCTION MANUAL

## GNExCP7-BG-S, GNExCP7-BG-D

Call Point

Class I & II Div 2 ; UL60947

NEC / CEC / ATEX / IECEx / UKEx Zone 1, 2, 21, 22

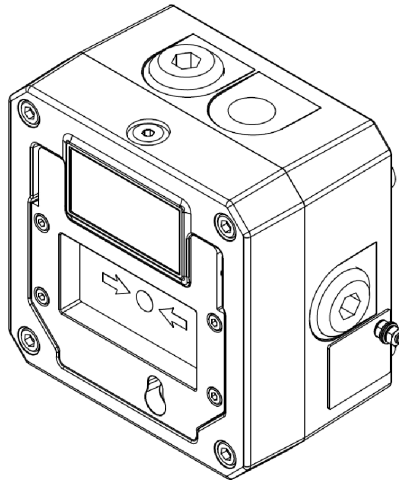

GNExCP7-BG

### 1) Product Table

Unit Type Code	Input Voltage	Input Current
GNExCP7-BG-S GNExCP7-BG-D	250Vac Max	5.0A Max ATEX/IECEX/UKEx 3.33A Max Class Div/Zone
GNExCP7-BG-S GNExCP7-BG-S-L GNExCP7-BG-D GNExCP7-BG-D-L	48Vdc Max	1.0A Max
	24Vdc Max	3.0 Max
GNExCP7-BG-S-C GNExCP7-BG-D-C	48Vdc Max	20mA Max

Table 1: Electrical Ratings

### 2) Warnings



#### WARNINGS:

USE COVER BOLTS CLASS A4-70  
DO NOT OPEN WHEN AN EXPLOSIVE ATMOSPHERE IS PRESENT  
POTENTIAL ELECTROSTATIC CHARGING HAZARD – SEE INSTRUCTIONS  
FOR INDOOR OR OUTDOOR USE  
TO REDUCE THE RISK OF IGNITION OF HAZARDOUS ATMOSPHERES, CONDUIT RUNS  
MUST HAVE A SEALING FITTING CONNECTED WITHIN 2 INCHES OF ENCLOSURE

#### AVERTISSEMENT:

UTILISER COUVRIR BOULONS CLASSE A4-70  
NE PAS OUVRIR UN PRÉSENCE D'ATMOSPHERE EXPLOSIVE  
DANGER POTENTIEL CHARGE ÉLECTROSTATIQUE - VOIR LES INSTRUCTIONS  
POUR USAGE INTÉRIEUR OU EXTÉRIEUR  
POUR RÉDUIRE LE RISQUE D'INFLAMMATION DES ATMOSPHÈRES DANGEREUSES, LES CONDUITES DE CONDUIT  
DOIVENT AVOIR UN RACCORD D'ÉTANCHÉITÉ RACCORDÉ À MOINS DE 2 POUCHES DE ENCLOS

### 3) Marking & Rating Information

The GNExCP7-BG Call Points comply with the following standards for hazardous locations:

#### 3.1 Class/Division Ratings for US & Canada



All models are approved for use as Alarm System use:

UL 60947-4-1 LOW-VOLTAGE SWITCHGEAR AND CONTROLGEAR - PART 4-1: CONTACTORS AND MOTORSTARTERS - ELECTROMECHANICAL CONTACTORS AND MOTOR-STARTERS- Edition 3 - Revision Date 2017/10/17

CSA C22.2 NO. 60947-4-1-14 LOW-VOLTAGE SWITCHGEAR AND CONTROLGEAR — PART 4-1: CONTACTORS AND MOTOR-STARTERS — ELECTROMECHANICAL CONTACTORS AND MOTOR-STARTERS- Edition 2 - Issue Date 2014/01/04

For Indoor and Outdoor Use  
Pour usage Interieur INTÉRIEUR

Ambient Temperature Range:  
-55°C to +60°C

Standards	
UL 60079-0:2017 (Ed 6): Explosive Atmospheres - Part 0: Equipment - General requirements UL 60079-1:2015 (Ed7): Explosive Atmospheres - Part 1: Equipment protection by flameproof enclosures "d" UL 60079-31:2012 (Ed 2): Explosive Atmospheres - Part 31: Equipment dust ignition protection by enclosure "t"	
CSA C22.2 NO. 60079-0:2015 (Ed 3) Explosive Atmospheres – Part 0: Equipment – General requirements CSA C22.2 NO. 60079-1:2016 (Ed 3): Explosive Atmospheres – Part 1: Equipment protection by flameproof enclosures "d" CSA C22.2 NO. 60079-31:2015 (Ed 2): Explosive Atmospheres – Part 31: Equipment dust ignition protection by enclosure "t"	
Class Division Ratings for US (NEC) & Canada (CEC)	
Model No:	Rating
GNExCP7-BG-S GNExCP7-BG-S-L GNExCP7-BG-S-C	Class I Div 2 Group ABCD T6 Ta -55°C to +60°C
GNExCP7-BG-D GNExCP7-BG-D-L GNExCP7-BG-D-C	Class II Div 2 Group FG T5 Ta -55°C to +60°C Class III Div 2 Ta -55°C to +60°C
Class Zone Ratings for US (NEC)	
Model No:	Rating
GNExCP7-BG-S GNExCP7-BG-S-L GNExCP7-BG-S-C	Class I Zone 1 AEx db IIC T6 Gb Ta -55°C to +60°C Zone 21 AEx tb IIIC T75°C Db Ta -55°C to +60°C
GNExCP7-BG-D GNExCP7-BG-D-L GNExCP7-BG-D-C	Class I Zone 1 AEx db IIC T6 Gb Ta -55°C to +60°C Zone 21 AEx tb IIIC T90°C Db Ta -55°C to +60°C

Class Zone Ratings for Canada (CEC)	
Model No:	Rating
GNExCP7-BG-S GNExCP7-BG-S-L GNExCP7-BG-S-C	Ex db IIC T6 Gb Ta -55°C to +60°C Ex tb IIIC T75°C Db Ta -55°C to +60°C
GNExCP7-BG-D GNExCP7-BG-D-L GNExCP7-BG-D-C	Ex db IIC T6 Gb X Ta -55°C to +60°C Ex tb IIIC T90°C Db Ta -55°C to +60°C
Installation must be carried out in compliance with the National Electric Code / Canadian Electric Code	

#### 3.2 ATEX / IECEx & UKEx Ratings

Standards	
EN60079-0:2018/IEC60079-0:2017 (ed.7): Explosive Atmospheres - Equipment General Requirements. EN60079-1:2014/IEC60079-1:2014 (ed.7): Explosive Atmospheres - Equipment Protection by Flameproof Enclosures "d". EN60079-31:2014/IEC60079-31:2022 (ed.3): Explosive Atmospheres - Equipment Dust Ignition Protection by enclosure "t".	
Model No:	Rating
GNExCP7-BG-S	Ex db IIC T6 Gb Ta -55°C to +70°C Ex tb IIIC T80°C Db Ta -55°C to +70°C
GNExCP7-BG-D GNExCP7-BG-S-L GNExCP7-BG-S-C	Ex db IIC T5 Gb Ta -55°C to +70°C Ex db IIC T6 Gb Ta -55°C to +65°C Ex tb IIIC T85°C Db Ta -55°C to +70°C
GNExCP7-BG-D-L GNExCP7-BG-D-C	Ex db IIC T4 Gb Ta -55°C to +70°C Ex db IIC T5 Gb Ta -55°C to +65°C Ex db IIC T6 Gb Ta -55°C to +50°C Ex tb IIIC T100°C Db Ta -55°C to +70°C
See Product table for electrical ratings of each unit model	

Certificate No. DEMKO 19 ATEX 2101X  
IECEx ULD 19.0007X  
UKEx UL UL21UKEX2134X

Epsilon x  
Equipment Group  
and Category:

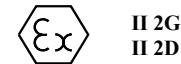

II 2G  
II 2D

CE Marking and  
Notified Body No.



2813

UKCA Marking and  
Notified Body No.



0518

#### 3.3 DNV Type Approval

The units have been tested and approved for the installation on ships in the following locations:

- Temperature:** Class A,B,C & D (all locations including open decks and masts)
- Humidity:** Class A & B (all locations)
- Vibration:** Class A (all locations except installation on machinery such as combustion engines, compressors, pumps, including piping on such machinery)
- EMC:** Class A & B (all locations including open decks and bridge)
- Enclosure:** Class A, B & C – IP56 (all locations except submerged applications and bilges)

#### 4) Zones, Gas Group, Category and Temperature Classification

The units can be installed in locations with the following conditions:

Area Classification Gas	
Zone 1	Explosive gas air mixture likely to occur in normal operation.
Zone 2	Explosive gas air mixture not likely to occur in normal operation, and if it does, it will only exist for a short time.
Gas Groupings	
Group IIA	Propane
Group IIB	Ethylene
Group IIC	Hydrogen and Acetylene
Temperature Classification for Gas Applications	
T1	450° C
T2	300° C
T3	200° C
T4	135° C
T5	100°C (GNE <sub>x</sub> CP7-BG-D-L up to 65°C ambient)
T6	85°C (GNE <sub>x</sub> CP7-BG-D up to 65°C ambient) (GNE <sub>x</sub> CP7-BG-D-L up to 50°C ambient)
Area Classification Dust	
Zone 21	Explosive dust air mixture likely to occur in normal operation.
Zone 22	Explosive dust air mixture not likely to occur in normal operation, and if it does, it will only exist for a short time.
Dust Groupings	
Group IIIA	Combustible Dusts
Group IIIB	Non-Conductive Dusts
Group IIIC	Conductive Dusts
Equipment Category	
2G, 2D	
Equipment Protection Level	
Gb, Gc, Db, Dc	
Maximum Surface Temperature for Dust Applications	
80°C (GNE <sub>x</sub> CP7-BG-S) ATEX/IECE <sub>x</sub> /UKEx 85°C (GNE <sub>x</sub> CP7-BG-D ; GNE <sub>x</sub> CP7-BG-S-L ; GNE <sub>x</sub> CP7-BG-S-C) ATEX/IECE <sub>x</sub> /UKEx 100°C (GNE <sub>x</sub> CP7-BG-D-L ; GNE <sub>x</sub> CP7-BG-D-C) ATEX/IECE <sub>x</sub> /UKEx 75°C (GNE <sub>x</sub> CP7-BG-S ; GNE <sub>x</sub> CP7-BG-S-L ; GNE <sub>x</sub> CP7-BG-S-C) Class Zone 90°C (GNE <sub>x</sub> CP7-BG-D ; GNE <sub>x</sub> CP7-BG-D-L ; GNE <sub>x</sub> CP7-BG-D-C) Class Zone	
Ambient Temperature Range	
-55°C to +70°C (-67°F to +158°F) ATEX/IECE <sub>x</sub> /UKEx -55°C to +60°C (-67°F to +140°F) Class Zone	
IP Rating	
IP66 to EN60529 4 / 4X / 3R / 13 to UL50E / NEMA250	

Installation must be carried out in compliance with the latest issue of the following standards:

EN60079-14 / IEC60079-14: Explosive atmospheres - Electrical installations design, selection and erection  
EN60079-10-1 / IEC60079-10-1: Explosive atmospheres - Classification of areas. Explosive gas atmospheres  
EN60079-10-2 / IEC60079-10-2: Explosive atmospheres - Classification of areas. Explosive dust atmospheres

#### 5) Specific Conditions for Safe Use

The stainless steel lift flap is not earthed and may generate an ignition-capable level of electrostatic charges. It has a max capacitance of 6.33pF according to CSA C22.2 NO. 60079-0 / UL 60079-0:2017, clause 7.5 or EN/IEC60079-0, clause 7.5.

Equipment is permitted to be wall mounted only in vertical position. The enclosure base is permitted in two mounting positions, with the double entry lowermost or uppermost.

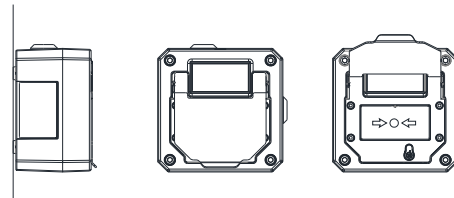
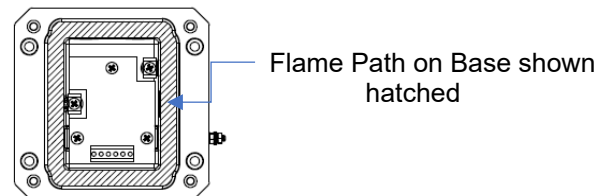
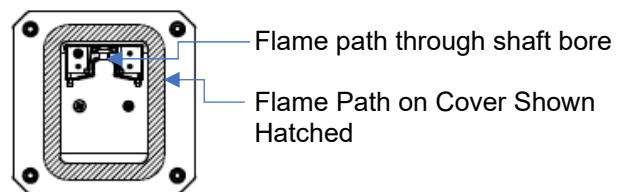

Fig 1 Wall Mounting

#### 6) Flame Path Positions



Flame Path on Base shown hatched



Flame path through shaft bore  
Flame Path on Cover Shown Hatched

No repair to the Flamepaths is permitted

#### 7) Location and Mounting

The location of the call point should enable ease of access for operation and testing. The unit should be mounted using the 4 off fixing holes which will accept up to M5 sized fixings. They should only be fixed to services that can carry the weight of the unit.

To gain access to the mounting holes in the base the front cover must be removed. See Section 8.

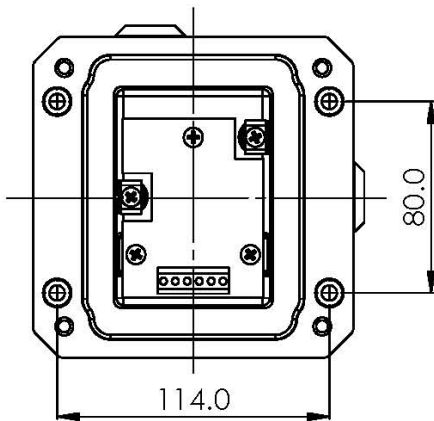
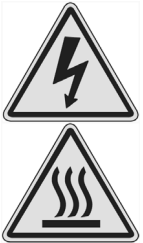

Fig. 1 View of base unit showing fixing centres (in mm).

## 8) Access to the Flameproof Enclosure



Warning – High voltage may be present, risk of electric shock. DO NOT open when energised, disconnect power before opening.

Warning – Hot surfaces. External surfaces and internal components may be hot after operation, take care when handling the equipment.

To access the Ex d chamber, remove the four off M6 x 60 hexagon socket head screws and withdraw the flameproof cover taking extreme care not to damage the flameproof faces in the process. M6 cover screws are Class A4-70 stainless steel and only screws of this category can be used for the enclosure.

On completion of the installation, the flameproof joints should be inspected to ensure that they are clean and that they have not been damaged during installation.

Once the screws are removed the cover will hang down out of the way to gain access to the terminals, the internal earth terminal and mounting hole recesses.

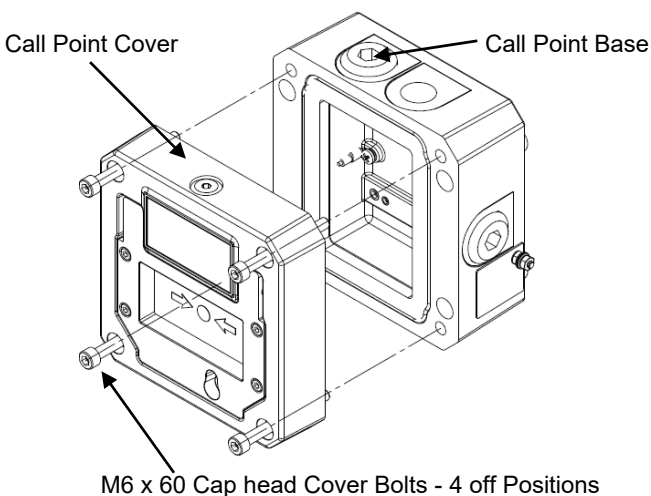

Fig. 2 Accessing the Explosion proof Enclosure.

Check that the earth bonding wire between the two castings is secure and the 'O' ring seal is in place.

When replacing the flameproof cover casting ensure that it is square with the flameproof chamber casting before inserting. Carefully place the cover on the base. Only after the cover is fully in place should the four M6 x 60 Stainless Steel A4-70 cover bolts and their spring washer be tightened down. Never use the cover bolts to force the cover into position.

## 9) Earthing

The units are provided with internal and external earth terminals which are mounted in the base of the unit.

Internal earthing connections should be made to the Internal Earth terminal in the base of the housing using a ring crimp terminal to secure the earth conductor under the earth clamp.

The earth conductor should be at least equal in size and rating to the incoming power conductors.

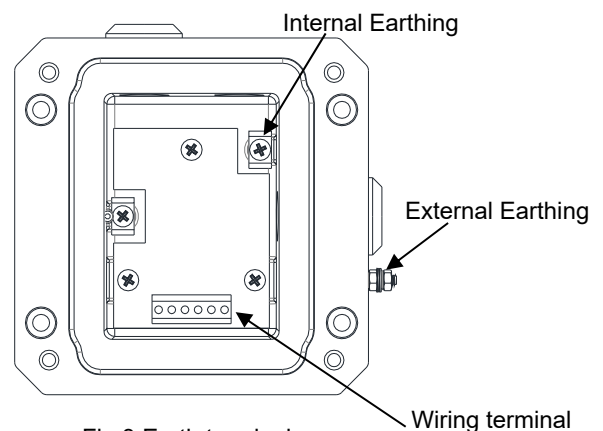

Fig 3 Earth terminals

## 10) Power Supply Selection Electrical Ratings

See table 1

250Vac max. / 5.0A max (3.33A max NEC/CEC)

48Vdc max. / 1.0A max

24Vdc max / 3.0A max

48Vdc max / 20mA (LED -C option with no ballast resistor)

## 11) Selection of Cable, Cable Glands, Blanking Elements & Adapters

ATEX/IECEx & UKEx Installations:

The equipment must only be installed by suitably qualified personnel in accordance with the latest issues of the relevant standards:

EN60079-14 / IEC60079-14: Explosive atmospheres - Electrical installations design, selection and erection

EN60079-10-1 / IEC60079-10-1: Explosive atmospheres - Classification of areas. Explosive gas atmospheres

The installation of the units must also be in accordance with any local codes that may apply and should only be carried out by a competent electrical engineer who has the necessary training.

The equipment must not be installed with any obstruction to the flanged flameproof joint any closer than permitted as per EN/IEC60079-14, table 13.

For high ambient temperatures the cable entry temperature may exceed +70°C or the cable branching point temperature may exceed 80°C and therefore suitable heat resisting cables and cable glands must be used, with a rated service temperature of at least the values stated below:

**For Single Switch models GNExCP7-BGS:**

Max. ambient temperature °C	50	55	60	65	70
req. Cable / Cable Gland rating: °C	76	81	86	91	96

**For Dual Switch models GNExCP7-BGD:**

Max. ambient temperature °C	40	45	50	55	60	65	70
req. Cable / Cable Gland rating: °C	85	90	95	100	105	110	115

The cable gland entries have an M20 x 1.5 entry thread. Only suitably rated ATEX / IECEx or UKEx certified cable glands which must be suitable for the type of cable being used and also meet the requirements of the current Ex 'd' flameproof installation standards EN 60079-14 / IEC60079-14.

When only one cable entry is used the other entries must be closed with suitably rated ATEX / IECEx or UKEx certified blanking plugs that meet the requirements of the current Ex 'db' and Ex 'tb' flameproof installation standards EN 60079-14 / IEC60079-14 (tightening torque 10Nm).

The stainless steel lift flap is not earthed and may generate an ignition-capable level of electrostatic charges. It has a max capacitance of 6.33pF according to EN/IEC60079-0, clause 7.5.

Caution do not change factory applied finishes.

**NEC / CEC Installations:**

The equipment must only be installed by suitably qualified personnel in accordance with the latest issues of the relevant standards:

The installation of the units must also be in accordance with any local codes that may apply and should only be carried out by a competent electrical engineer who has the necessary training.

The equipment must not be installed with any obstruction to the flanged flameproof joint any closer than permitted as per the NEC/CEC.

For high ambient temperatures the cable entry temperature may exceed +60°C or the cable branching point temperature may exceed 60°C and therefore suitable heat resisting cables and cable glands must be used, with a rated service temperature of at least the values stated below:

**For Single Switch model GNExCP7-BG-S:**

Max. ambient temperature °C	35	40	45	50	55	60
req. Cable / Cable Gland rating: °C	61	66	71	76	81	86

**For Dual Switch model GNExCP7-BG-D:**

Max. ambient temperature °C	20	25	30	35	40	45	50	55	60
req. Cable / Cable Gland rating: °C	65	70	75	80	85	90	95	100	105

For use in Class I Division II locations, in order to maintain the db type protection, flameproof conduit seals and/or cable glands must be used.

The cable gland entries have an M20 x 1.5 entry thread. Only suitably rated and certified cable glands which must be suitable for the type of cable being used and also meet the requirements of the current Ex 'db' and Ex 'tb' flameproof and NEC/CEC installation standards (tightening torque 10Nm).

When only one cable entry is used the other entries must be closed with suitably rated and certified blanking plugs that meet the requirements of the current Ex 'db' and Ex 'tb' flameproof and NEC/CEC installation standards (tightening torque 10Nm).

**All Installations:**

To access the Ex d chamber, remove the four off M6 x 60 stainless steel A4-70 Cap Head cover bolts.

If the installation is made using conduit, openings must have a sealing fitting connected as close as practical to the wall of the enclosure, but in no case more than the size of the conduit or 2" of enclosure, whichever is the lesser.

Electrical connections are to be made into the PCB / terminal blocks / DIN rail provided.

Internal earthing connections should be made to the Internal Earth terminal on the PCBA. The earth conductor should be at least equal in size and rating to the incoming power conductors.

On completion of the installation the flameproof joint surfaces should be inspected to ensure that they are clean and that they have not been damaged during installation. Flamepaths are not intended to be repaired.

When fitting the flameproof cover ensure the cover is sitting flat and correctly positioned on the base. Insert the M6 x 60 stainless steel A4-70 Cap Head cover bolts and fully tighten down (tightening torque 3.5Nm), ensuring no gap is visible between the cover and base of the enclosure.

If a high IP (Ingress Protection) rating is required then a suitable sealing washer must be fitted under the cable glands or blanking plugs.

The enclosure is non-conducting and may generate an ignition-capable level of electrostatic charges under certain extreme conditions. The user should ensure that the equipment is not installed in a location where it may be subjected to external conditions that might cause a build-up of electrostatic charges on non-conducting surfaces.

The M12 Cap fitted to the top side of the unit is not a user serviceable part and must not be removed during installation and maintenance.

The GNExCP7 Call Point range can be supplied with the following types of adapters:

- M20 to ½" NPT
- M20 to ¾" NPT
- M20 to M25

It is important to note that stopping plugs cannot be fitted onto adapters, only directly onto the M20 entries.

Any other adapters used must be suitably rated and ATEX / IECEx / UKEx or NEC/CEC certified adapters.

## 12) Cable & Wiring Connections

The units come with two options.

A DIN rail version which has 8-way connection and allows for limited wiring of EOL devices by customer, or, full pre-wired configurations if outlined with order to E2S.

For full wiring details see wiring diagrams D202-06-211

The PCB Terminal Version has a 6-way connector but is designed to allow for full customer configuration with Series and EOL devices in a number of wiring configurations. E2S can also configure unit at time of order to E2S

For full wiring details see wiring diagrams D202-06-212

For EOL and Series device limitations and configurations see Section 15. Fitting can be requested by E2S at the order stage or added to the correct terminal blocks afterward. All devices must comply with the requirements stipulated in section 15.

Electrical Connections are to be made into the terminal blocks using solid or stranded wire.

Wires having a cross sectional area between 0.5 mm<sup>2</sup> to 2.5mm<sup>2</sup> (AWG 20 – 14) can be connected to each terminal way.

In most configuration an input and output wire can be fitted to individual terminals, where these are more complex and if fitting 2-off wires to one terminal way, the sum of the 2-off wires must be a maximum cross sectional area of 2.5mm<sup>2</sup>.

Strip wires to 8mm. Wires may also be fitted using ferrules.

DIN Rail Terminals: 0.51 Nm / 4.5 Lb-in;

Connector Block Terminals: 0.87 Nm / 7.7 Lb-in;

PCBA Main Terminals: 0.45 Nm / 4.0 Lb-in;

PCBA EOL and Series (1 & 2) Terminals: 0.38 Nm / 3.4 Lb-in

When connecting wires to the terminals great care should be taken to dress the wires so that when the cover is inserted into the chamber the wires do not exert excess pressure on the terminal blocks. This is particularly important when using cables with large cross-sectional areas such as 2.5mm<sup>2</sup>.

## 13) Testing unit operation

The break glass unit can be tested without the need to break/replace the frangible glass element.

A test key (Plastic Key Supplied with unit) is used to mechanically drop the glass down activating the switch.

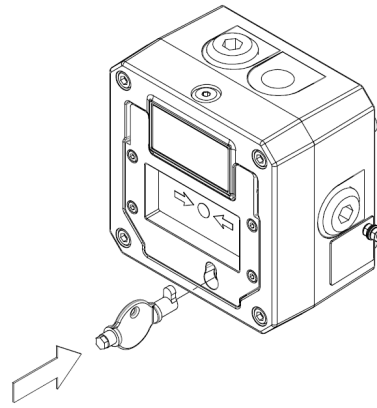

The test key is inserted in the test cam and rotated clockwise by an angle of 90° the glass element will visibly drop down in the viewable window.

The call point switch will now change over its contacts to operate the alarm.

Once testing is complete the unit needs to be reset, the test key is rotated back anticlockwise 90° to its original vertical position. The glass element should now raise up so it is level again (horizontal) in the viewable window.

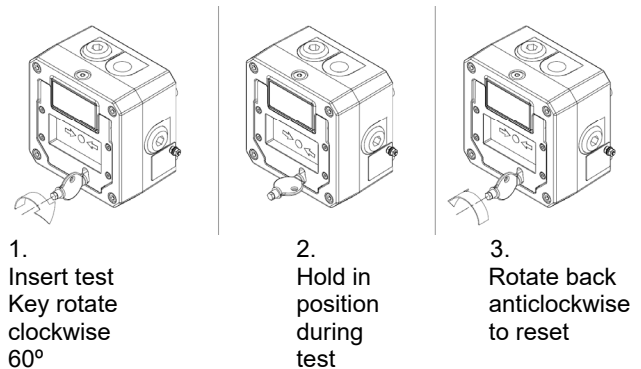

## 14) Replacement of glass element

If the break glass unit has been operated the broken glass element can be quickly replaced.

The break glass cover plate is removed by unscrewing the 4 off M4 cap head screws attaching it.

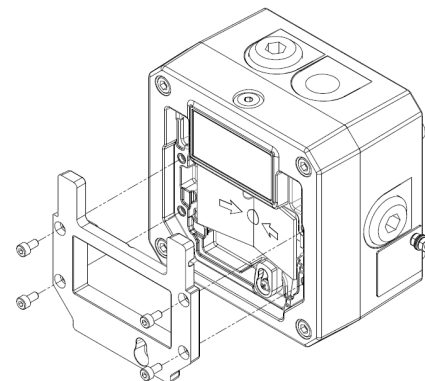

Once the cover is removed the broken glass will be free to be removed, clean out any other fragments of glass carefully.

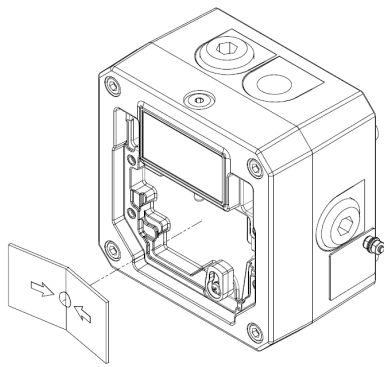

To fit the new glass element rotate the test cam clockwise by an angle of 90° (use test key supplied) this will then allow the glass to fit back into the pocket it sits in, resting on the pivot point and test cam, ensure the plunger shaft is resting on the top of the glass, it might need to be pushed up slightly to achieve this.

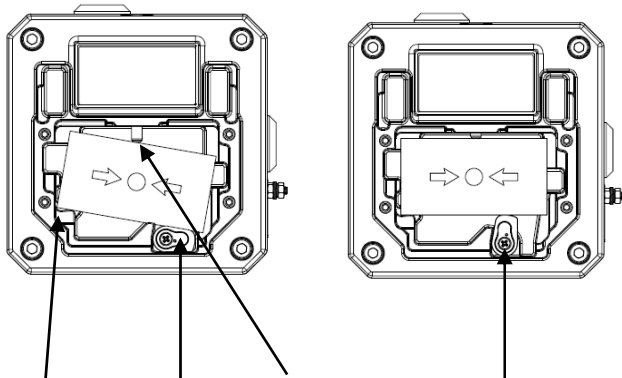

Pivot point    Test Cam    Plunger Shaft    Rotate test cam back Upright set point

Whilst lightly holding the glass in place rotate the test cam back anticlockwise 90° to its original vertical position. The glass element should now raise up so it is level again (horizontal) in the viewable window.

Replace the cover plate and tighten the 4 off M4 cap head screws.

Ensure the glass element is free to move under the cover plate. This can be done by running through the units test operation. See section 13 of this instruction manual.

## 15) End-of-Line and Series Devices

All models can be fitted with series resistors, end-of-line monitoring resistors, monitoring diodes and zener diodes if supplied with direct current up to 48Vdc and limited to a maximum total power consumption no greater than 6.224W.

Min. resistor values and current limitations must be observed depending on supply voltage and type of components fitted. If a combination of resistors / diodes / zener diodes is used, values for all components must be observed and lowest current limit for either component becomes overall limit.

Current limitation for units fitted with end-of-line resistors, diodes or zener diodes must be ensured by using a current limited power supply or fitting a current limiting resistor at the control panel (not provided).

The following table 2 shows limitations for all possible variations:

Type of component fitted	Supply voltage 24Vdc		Supply voltage 48Vdc	
	value	Max. current (mA)	value	Max. current
End-of-Line Resistor *See note	min. 470R/ 2W or min. 2k2 / 0.5W	3000	min. 2k2 / 2W or min. 8k2 / 0.5W	1000
End-of-Line Diode Type 1N5401	2W	59.13	2W	25.26
Series Resistor *See note	min. 470R/ 2W or min. 2k2 / 0.5W	3000	min. 2k2 / 2W or min. 8k2 / 0.5W	1000
Series Diode Type 1N5401	2W	59.13	2W	25.26
Series Zener Diode Type 1N5333B	3.3V	230	3.3V	230
	4.7V	162	4.7V	162
	5.1V	149	5.1V	149
	5.6V	136	5.6V	136
	6.2V	122	6.2V	122
	6.8V	112	6.8V	112
	10V	76	10V	76
	12V	63	12V	63

Table 2 : EOL and Series Devices limits

EOL (End of line) device;

- resistor – ExxxR
- diode – ED1
- zener – ExxxZ

Series (In line) device;

- resistor – SxxxR
- diode – SD1
- zener – SxxxZ
- LED

Microswitch 1 = M/S 1

Microswitch 2 = M/S 2

The unit can be wired with a maximum of 4 module devices – see wiring diagram D202-06-211 or D202-06-212

Note:- The maximum voltage stated must not be exceeded, as the internal resistor modules are rated as compliant with Ex d according to the units voltage

An optional Ex d LED monitoring module is designated after the model no as either, GNEXP7-BG-S-L or GNEXP7-BG-D-L to include an LED and power limiting resistor or, GNEXP7-BG-S-C or GNEXP7-BG-D-C with includes the LED but where the units current must be limited to 20mA. As the LED has no power limiting resistor.

The optional Ex d LED monitoring module is fitted in the M20 side entry as shown, when the main M20 entries are at the bottom of unit.

The wiring is shown as per wiring diagrams D202-06-211 or D202-06-212 see the various LED configuration options.

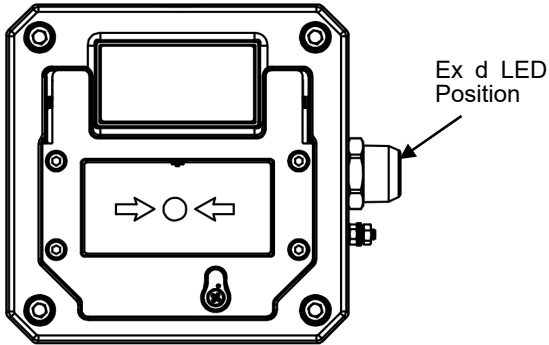

### 16) Maintenance, Overhaul, Repair and Cleaning

Maintenance, repair and overhaul of the equipment should only be carried out by suitably qualified personnel in accordance with the current relevant standards:

For ATEX / IECEx / UKEx

EN 60079-19 Explosive atmospheres – Equipment repair, overhaul and reclamation

EN 60079-17 Explosive atmospheres – Electrical installations inspections and maintenance

Electrostatic charging hazard – clean only with a damp cloth.

Units must not be opened while an explosive atmosphere is present.

For US & CEC Class / Div / Zone

UL 60079-19 Explosive atmospheres - Equipment repair, overhaul and reclamation

UL 60079-17 Explosive atmospheres - Electrical installations inspection and maintenance

### 17) SIL 2 Reliability Data

Reliability and Functional safety IEC/EN61508 which has been assessed and is considered suitable for use in low demand safety function:

- Random Hardware Failures and Systematic Failures (route 2H)
- As an unvoted item (i.e. hardware fault tolerance of 0) at SIL 2

The product was assessed against failure modes:

- Failure to close a contact when the call point is struck with specified force
- Failure to open a contact when the call point is struck with specified force
- Spurious output despite no input

Integrity in respect of failure to close	SIL 2
System Type	A
Hardware Fault Tolerance	0
Safe Failure Fraction (credible claim)	75%
PFD (hazardous failure)	$2.3 \times 10^{-3}$
Proof Test Interval	Up to 1 year



**SINGLE MICROSWITCH DEVICES**

**SHEET 1**

PRODUCTS:  
GNExCP7, STExCP8  
& WP7

Diagram	Sheet
Dual Switch Wiring Configurations	2,3,5,6,7,8
LED Indicator Wiring Configurations	4,5,6,8
Parallel Dual Switch Wiring Configurations	7, 8

GNEXCP7-BG[s][t][l][e][m][d][v][o][x][u]-[v][e][s] Series  
 Switch Type [s] Terminals [t] Product Version [v] Product Option [o] LED Indicator [u] EOL Module [e]

Module Device Codes		
	EOL	Series
Resistor	ExxxR	SxxxR
Diode	ED1	SD1
Zener Diode	ExxxZ	SxxxZ
LED	N/A	L or C

ISSUE	MOD No.	REASON - INITIAL - DATE
5	ACN0102	Addition of BG version ; Options clarified RNP 15-04-2022
6	ACN0127	Configuration coding added and aligned with other call points. LED options added ; PCB page moved to new document. RNP 14-07-2023

SINGLE SWITCH	CONFIG. D1-1	SINGLE SWITCH WITH SERIES DEVICE	CONFIG. D1-2	SINGLE SWITCH WITH EOL & SERIES DEVICES	CONFIG. D1-3	SINGLE SWITCH WITH EOL & ALT. SERIES DEVICES	CONFIG. D1-4
---------------	--------------	----------------------------------	--------------	---	--------------	--	--------------

SWITCH TYPE [s] [S] TERMINALS [t] [D] PRODUCT OPTION [o] [1] LED INDICATOR [u] [N]	Single DIN Rail Default NO LED	SWITCH TYPE [s] [S] TERMINALS [t] [D] PRODUCT OPTION [o] [1] LED INDICATOR [u] [N] SERIES MODULE [s] [Sxxxx]	Single DIN Rail Default NO LED Series Device	SWITCH TYPE [s] [S] TERMINALS [t] [D] PRODUCT OPTION [o] [1] LED INDICATOR [u] [N] MODULES [e][s] [Exxxx][Sxxxx]	Single DIN Rail Default NO LED EOL + Series	SWITCH TYPE [s] [S] TERMINALS [t] [D] PRODUCT OPTION [o] [W] LED INDICATOR [u] [N] MODULE [e][s] [Exxxx][Sxxxx]	Single DIN Rail Alt. EOL Pos'n. NO LED EOL + Series
---	---	--	--	--	---	---	---

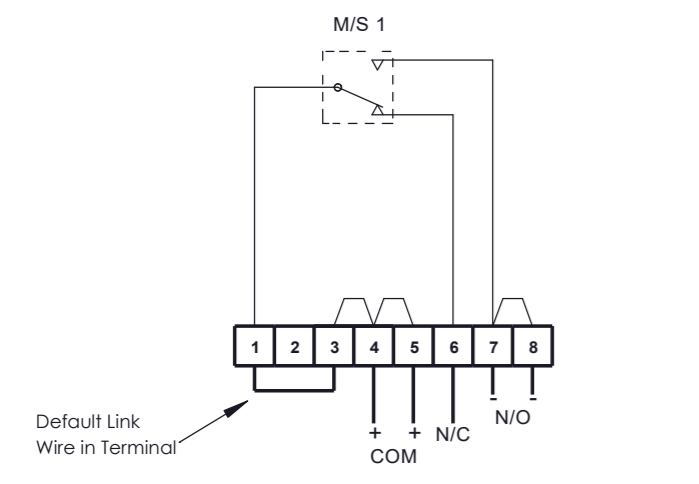
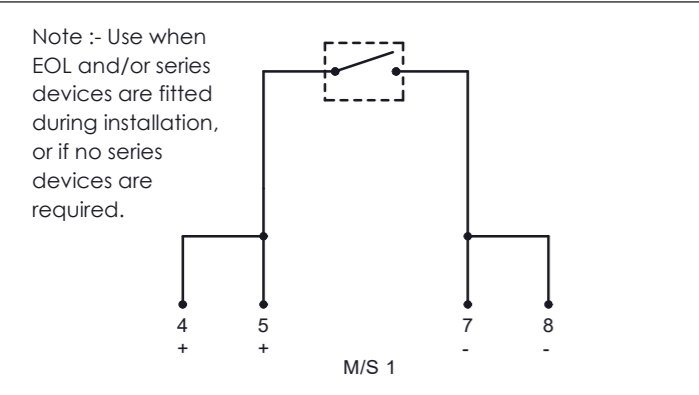

**Circuit shown in Unoperated condition**

**Unoperated condition (Glass Intact / Standby Condition)**  
 Terminals +(4,5) & -(7,8) open  
 Terminals +(4,5) & (6) closed

**Operated condition (Glass Broken / Button pushed in)**  
 Terminals +(4,5) & -(7,8) closed  
 Terminals +(4,5) & (6) open

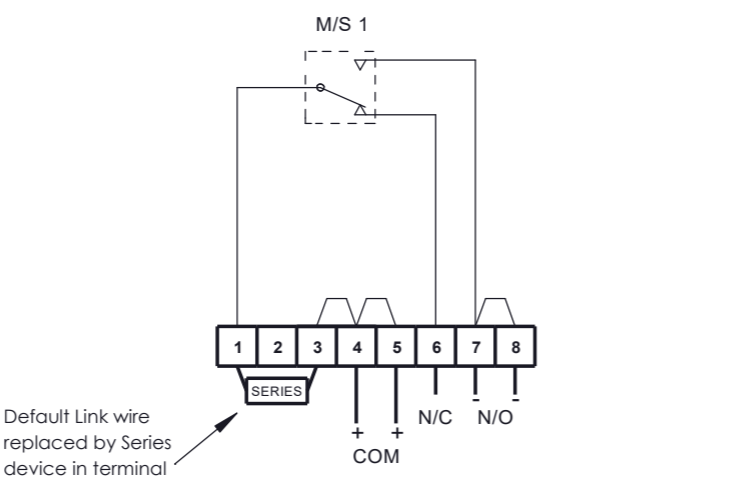
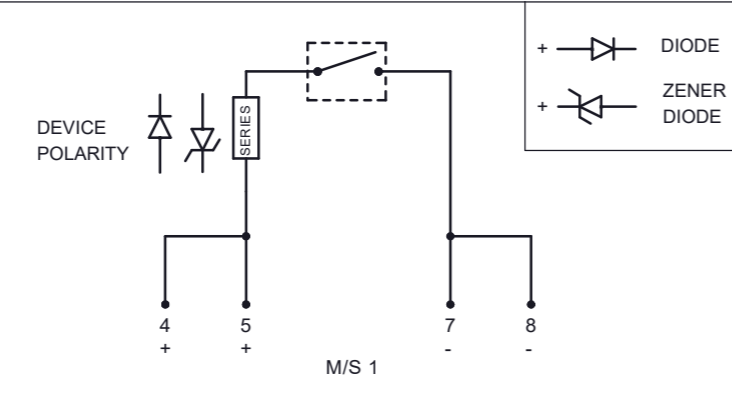

**Circuit shown in Unoperated condition**

**Unoperated condition (Glass Intact / Standby Condition)**  
 Terminals +(4,5) & -(7,8) open  
 Terminals +(4,5) & (6) closed

**Operated condition (Glass Broken / Button pushed in)**  
 Terminals +(4,5) & -(7,8) closed  
 Terminals +(4,5) & (6) open

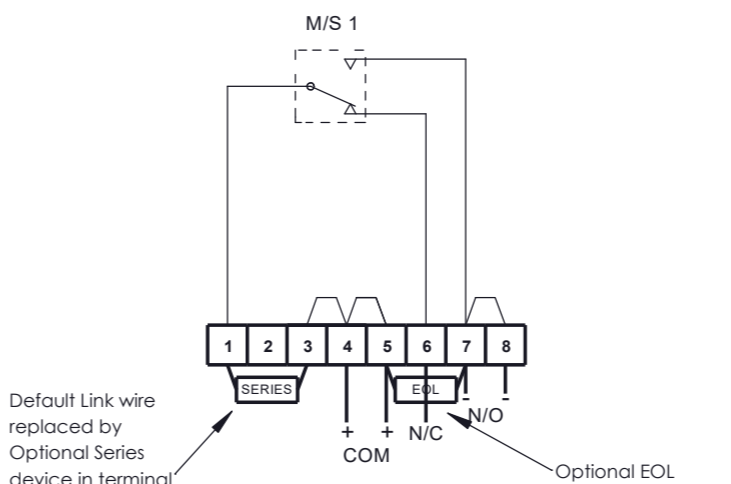
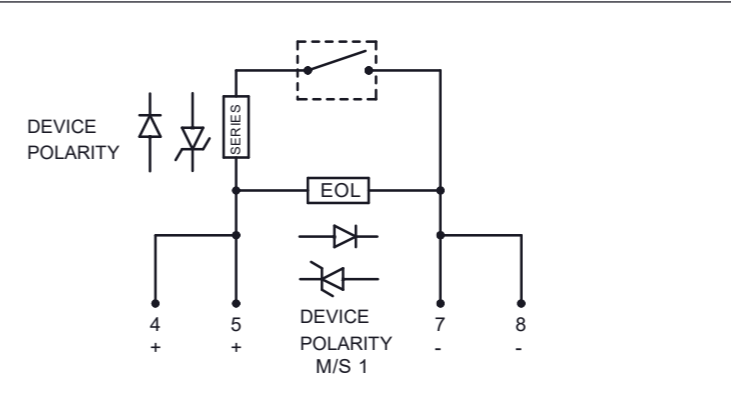

**Circuit shown in Unoperated condition**

**Unoperated condition (Glass Intact / Standby Condition)**  
 Terminals +(4,5) & -(7,8) open  
 Terminals +(4,5) & (6) closed

**Operated condition (Glass Broken / Button pushed in)**  
 Terminals +(4,5) & -(7,8) closed  
 Terminals +(4,5) & (6) open

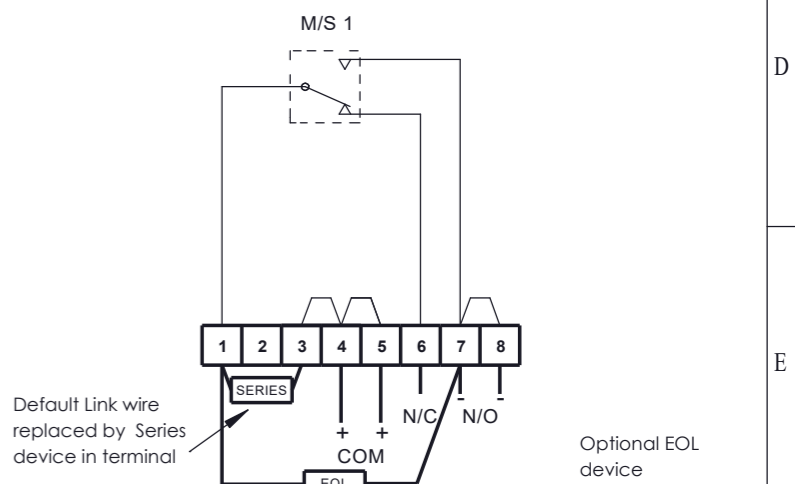
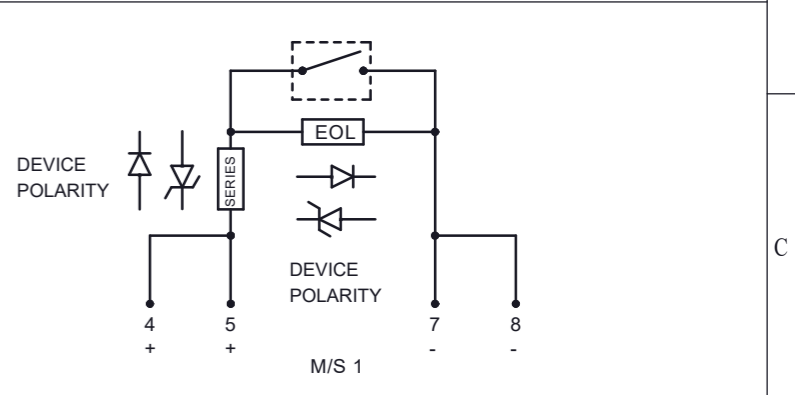

**Circuit shown in Unoperated condition**

**Unoperated condition (Glass Intact / Standby Condition)**  
 Terminals +(4,5) & -(7,8) open  
 Terminals +(4,5) & (6) closed

**Operated condition (Glass Broken / Button pushed in)**  
 Terminals +(4,5) & -(7,8) closed  
 Terminals +(4,5) & (6) open

DRAWING TO BS8888:2000  
 GEOMETRIC TOLERANCES TO ISO1101:1983  
 LINEAR DIMENSIONAL TOLS  
 ANGULAR DIMENSIONAL TOLS

STANDARDS  
**GNExCP7 ; STExCP8 ; WP7 units with DIN Rail**

DRAWN	DATE
R.S.RAIT	05-03-2020
CHECKED	DATE
B.ISARD	05-03-2020
APPROVED	DATE
R.N.POTTS	05-03-2020

SURFACE FINISH	WEIGHT (Kg)
MATERIAL	
ALTERNATIVE MATERIAL	

THIS DRAWING AND ANY INFORMATION OR DESCRIPTIVE MATTER THEREIN IS COMMUNICATED IN CONFIDENCE AND IS THE COPYRIGHT PROPERTY OF EUROPEAN SAFETY SYSTEMS LTD. NEITHER THE WHOLE OR ANY EXTRACT MAY BE DISCLOSED, LOANED, COPIED OR USED FOR MANUFACTURING OR TENDERING PURPOSES WITHOUT THEIR WRITTEN CONSENT.

© EUROPEAN SAFETY SYSTEMS LTD. AS PER LATEST DATE OF ISSUE SHOWN ABOVE

EUROPEAN SAFETY SYSTEMS LTD  
 IMPRESS HOUSE  
 MANSELL ROAD  
 ACTON  
 LONDON W3 7QH  
 WWW.E2S.COM

ALL DIMENSIONS IN MM IF IN DOUBT, ASK - DO NOT SCALE		
TITLE <b>GNExCP7 ; STExCP8 ; WP7 CALL POINT WIRING / CIRCUIT OPERATION DIAGRAM</b>		<b>A3</b>
SCALE NTS	SHEET 1 OF 8	DRAWING NUMBER <b>D202-06-211</b>

# DUAL MICROSWITCH DEVICES

# SHEET 2

Notes:  
1. Other configurations of dual switch units are possible. Contact E2S sales to discuss options.

GNEXCP7-BG[s][t][l][e][m][d][v][o][x][u]-[v][e][s] Series  
 Switch Type [s] Terminals [t] Product Version [v] Product Option [o] LED Indicator [u] EOL Module [e]

Module Device Codes		
	EOL	Series
Resistor	ExxxR	SxxxR
Diode	ED1	SD1
Zener Diode	ExxxZ	SxxxZ
LED	N/A	L or C

ISSUE	MOD No.	REASON - INITIAL - DATE
5	ACN0102	Addition of BG version ; Options clarified RNP 15-04-2022
6	ACN0127	Configuration coding added and aligned with other call points. LED options added ; PCB page moved to new document. RNP 14-07-2023

DUAL SWITCH WITH EOL DEVICE	CONFIG. D2-1	DUAL SWITCH WITH SERIES DEVICES	CONFIG. D2-2	DUAL SWITCH WITH EOL & SERIES DEVICES	CONFIG. D2-3	DUAL SWITCH WITH EOL & SERIES DEVICES	CONFIG. D2-4
SWITCH TYPE [s] [D] TERMINALS [t] [D] PRODUCT OPTION [o] [1] LED INDICATOR [u] [N]	Dual DIN Rail Default NO LED	SWITCH TYPE [s] [D] TERMINALS [t] [D] PRODUCT OPTION [o] [1] LED INDICATOR [u] [N] SERIES MODULE [s] [Sxxxx]	Dual DIN Rail Only Default NO LED Series Device	SWITCH TYPE [s] [D] TERMINALS [t] [D] PRODUCT OPTION [o] [1] LED INDICATOR [u] [N] MODULES [e] [s] [Exxxx][Sxxxx]	Dual DIN Rail Only Default NO LED EOL + Series	SWITCH TYPE [s] [D] TERMINALS [t] [D] PRODUCT OPTION [o] [W] LED INDICATOR [u] [N] MODULES [e] [s] [Exxxx][Sxxxx]	Dual DIN Rail Only Alt. EOL Pos'n. NO LED EOL + Series

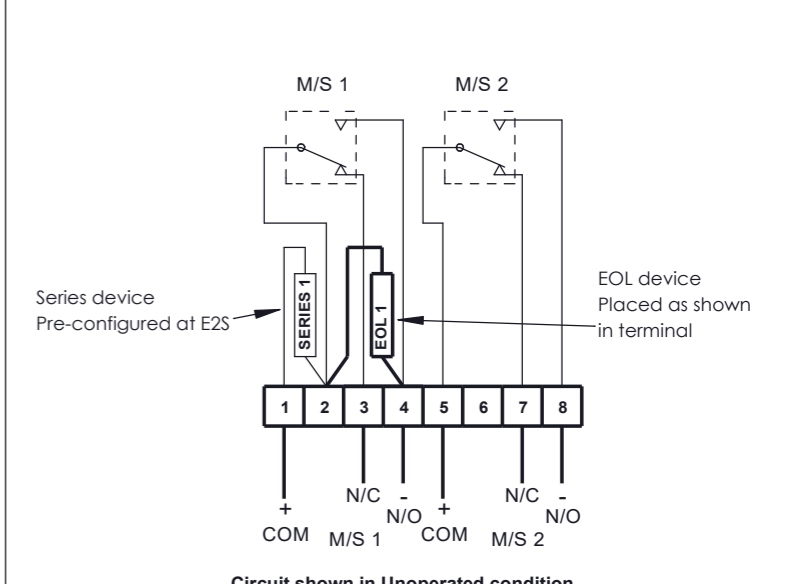
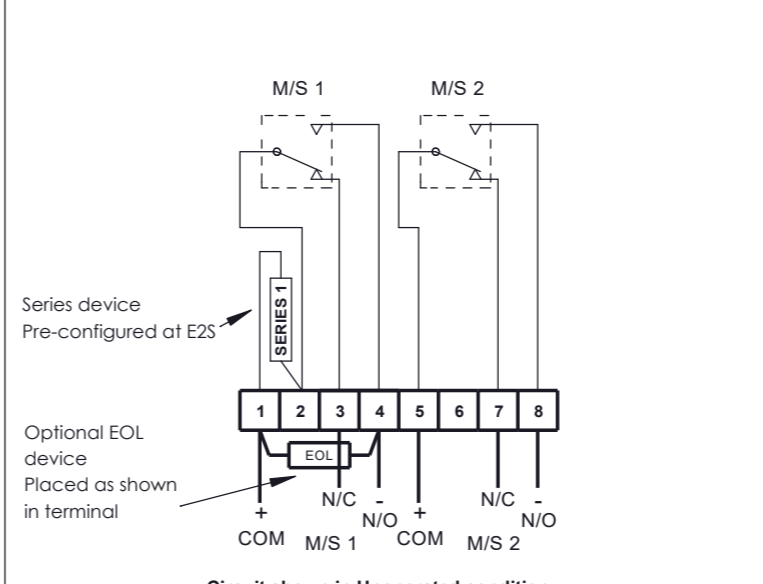
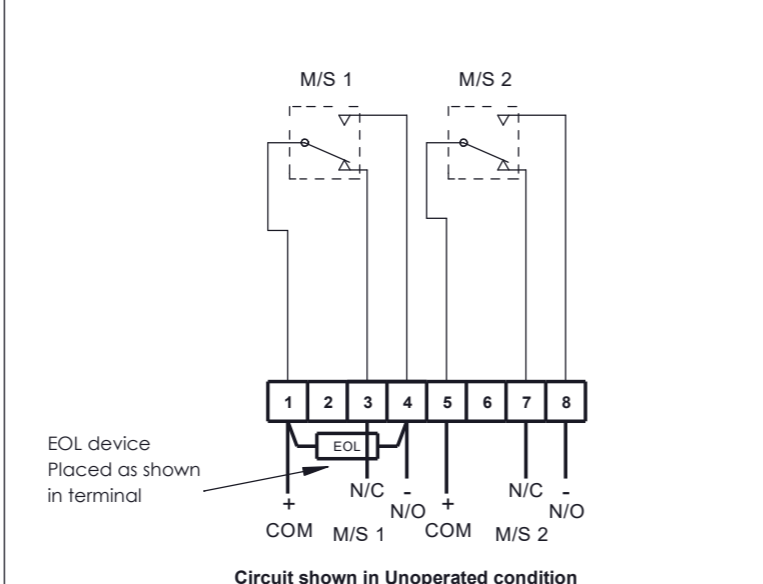
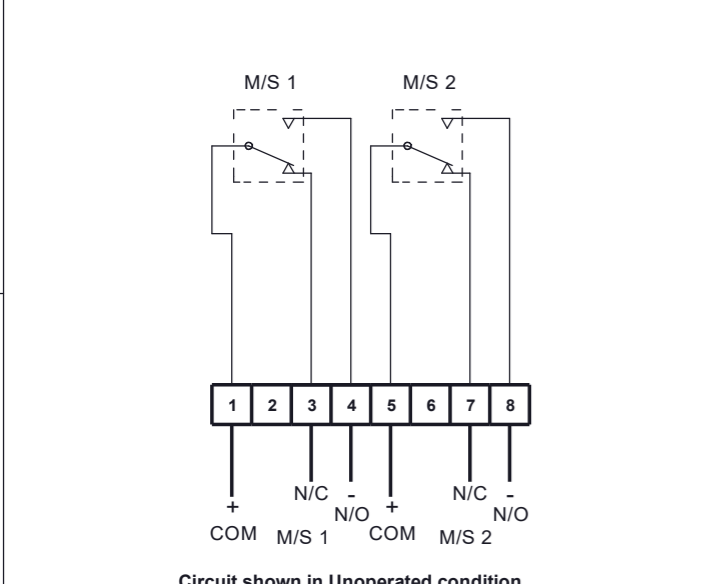
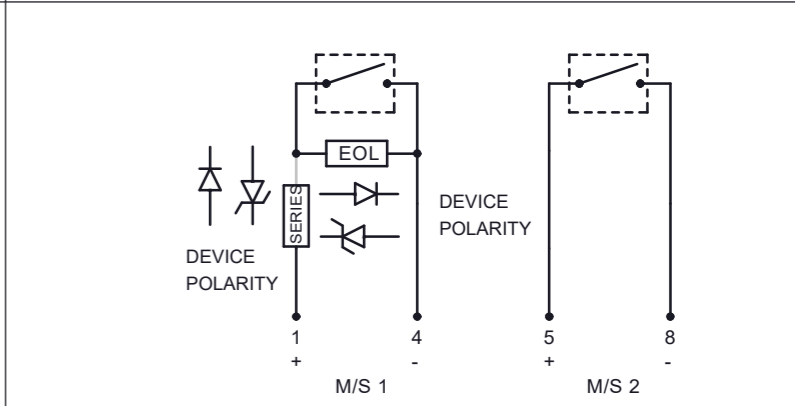
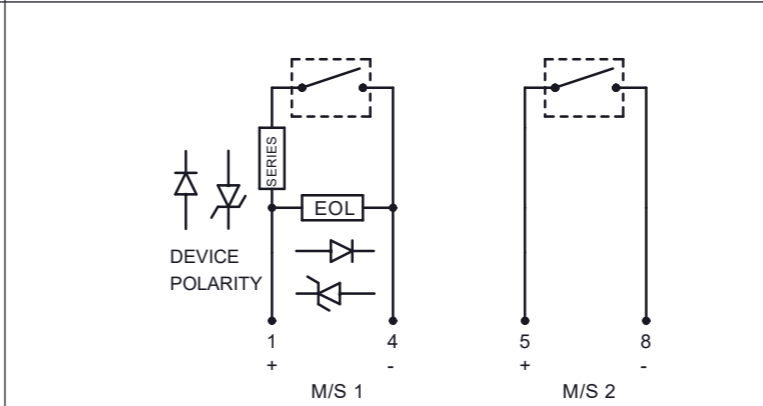
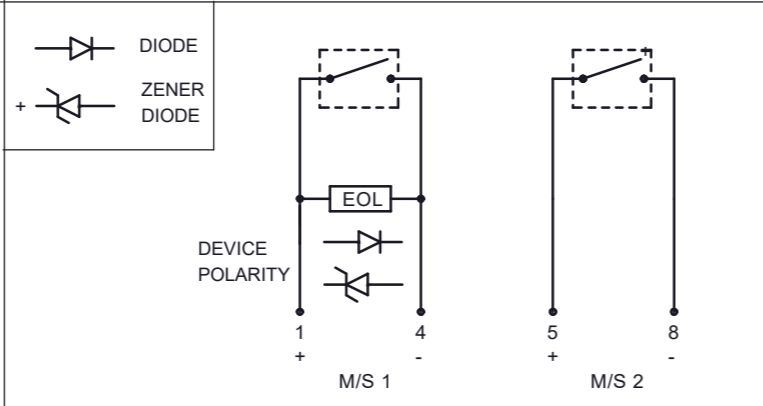
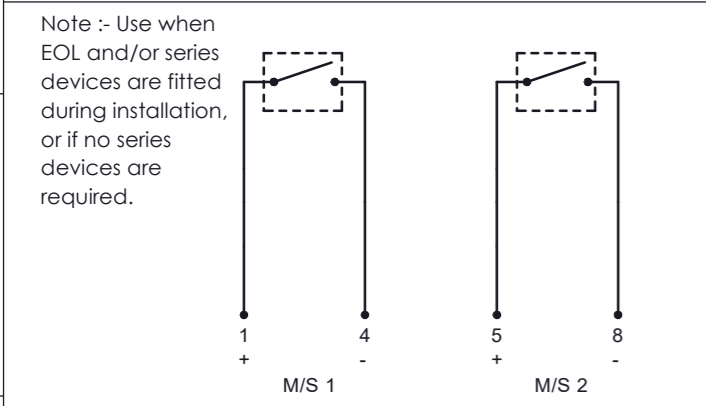

**Circuit shown in Unoperated condition**

**Unoperated condition (Glass Intact / Standby Condition)**  
 Terminals +(1) & -(4) M/S 1 & +(5) & -(8) M/S 2 open  
 Terminals +(1) & -(3) M/S 1 & +(5) & -(7) M/S 2 closed

**Operated condition (Glass Broken / Button pushed in)**  
 Terminals +(1) & -(3) M/S 1 & +(5) & -(7) M/S 2 open  
 Terminals +(1) & -(4) M/S 1 & +(5) & -(8) M/S 2 closed

**Circuit shown in Unoperated condition**

**Unoperated condition (Glass Intact / Standby Condition)**  
 Terminals +(1) & -(4) M/S 1 & +(5) & -(8) M/S 2 open  
 Terminals +(1) & -(3) M/S 1 & +(5) & -(7) M/S 2 closed

**Operated condition (Glass Broken / Button pushed in)**  
 Terminals +(1) & -(3) M/S 1 & +(5) & -(7) M/S 2 open  
 Terminals +(1) & -(4) M/S 1 & +(5) & -(8) M/S 2 closed

**Circuit shown in Unoperated condition**

**Unoperated condition (Glass Intact / Standby Condition)**  
 Terminals +(1) & -(4) M/S 1 & +(5) & -(8) M/S 2 open  
 Terminals +(1) & -(3) M/S 1 & +(5) & -(7) M/S 2 closed

**Operated condition (Glass Broken / Button pushed in)**  
 Terminals +(1) & -(3) M/S 1 & +(5) & -(7) M/S 2 open  
 Terminals +(1) & -(4) M/S 1 & +(5) & -(8) M/S 2 closed

**Circuit shown in Unoperated condition**

**Unoperated condition (Glass Intact / Standby Condition)**  
 Terminals +(1) & -(4) M/S 1 & +(5) & -(8) M/S 2 open  
 Terminals +(1) & -(3) M/S 1 & +(5) & -(7) M/S 2 closed

**Operated condition (Glass Broken / Button pushed in)**  
 Terminals +(1) & -(3) M/S 1 & +(5) & -(7) M/S 2 open  
 Terminals +(1) & -(4) M/S 1 & +(5) & -(8) M/S 2 closed

DRAWING TO BS8888:2000  
 GEOMETRIC TOLERANCES TO ISO1101:1983  
 LINEAR DIMENSIONAL TOLS  
 ANGULAR DIMENSIONAL TOLS

STANDARDS  
**GNExCP7 ; STExCP8 ; WP7 units with DIN Rail**

DRAWN **D.HOWGILL** DATE **05-03-2020**  
 CHECKED **R.N.POTTS** DATE **05-03-2020**  
 APPROVED **R.N.POTTS** DATE **05-03-2020**

SURFACE FINISH  
 WEIGHT (Kg)  
 MATERIAL  
 ALTERNATIVE MATERIAL

THIS DRAWING AND ANY INFORMATION OR DESCRIPTIVE MATTER THEREIN IS COMMUNICATED IN CONFIDENCE AND IS THE COPYRIGHT PROPERTY OF EUROPEAN SAFETY SYSTEMS LTD. NEITHER THE WHOLE OR ANY EXTRACT MAY BE DISCLOSED, LOANED, COPIED OR USED FOR MANUFACTURING OR TENDERING PURPOSES WITHOUT THEIR WRITTEN CONSENT.

EUROPEAN SAFETY SYSTEMS LTD.  
 AS PER LATEST DATE OF ISSUE SHOWN ABOVE

**e2S** warning signals  
 EUROPEAN SAFETY SYSTEMS LTD  
 IMPRESS HOUSE  
 MANSELL ROAD  
 ACTON  
 LONDON W3 7QH  
 WWW.E2S.COM

ALL DIMENSIONS IN MM  
 IF IN DOUBT, ASK - DO NOT SCALE

TITLE **GNExCP7 ; STExCP8 ; WP7 CALL POINT WIRING / CIRCUIT OPERATION DIAGRAM**

SCALE **NTS** SHEET **2 OF 8** DRAWING NUMBER **D202-06-211**

**DUAL MICROSWITCH DEVICES DUPLICATED**

**SHEET 3**

GNEXCP7-BG[s][t][l][e][m][d][v][o][x][u]-[v][e][s] Series  
 Switch Type [s] Terminals [t] Product Version [v] Product Option [o] LED Indicator [u] EOL Module [e]

Module Device Codes		
	EOL	Series
Resistor	ExxxR	SxxxR
Diode	ED1	SD1
Zener Diode	ExxxZ	SxxxZ
LED	N/A	L or C

ISSUE	MOD No.	REASON - INITIAL - DATE
5	ACN0102	Addition of BG version ; Options clarified RNP 15-04-2022
6	ACN0127	Configuration coding added and aligned with other call points. LED options added ; PCB page moved to new document. RNP 14-07-2023

Notes:  
 1. Other configurations of dual switch units are possible. Contact E2S sales to discuss options.

DUAL SWITCH WITH EOL DEVICES DUPLICATED	CONFIG. D3-1	DUAL SWITCH WITH SERIES DEVICES DUPLICATED	CONFIG. D3-2	DUAL SWITCH WITH EOL & SERIES DEVICE DUPLICATED	CONFIG. D3-3	DUAL SWITCH WITH EOL & SERIES DEVICE DUPLICATED	CONFIG. D3-4
SWITCH TYPE [s] [D] TERMINALS [t] [D] PRODUCT OPTION [o] [2] LED INDICATOR [u] [N] EOL MODULE [e] [Exxxx]	Dual DIN Rail Duplicated NO LED EOL Device	SWITCH TYPE [s] [D] TERMINALS [t] [D] PRODUCT OPTION [o] [2] LED INDICATOR [u] [N] SERIES MODULE [s] [Sxxxx]	Dual DIN Rail Only Duplicated NO LED Series Device	SWITCH TYPE [s] [D] TERMINALS [t] [D] PRODUCT OPTION [o] [2] LED INDICATOR [u] [N] MODULES [e][s] [Exxxx][Sxxxx]	Dual DIN Rail Only Duplicated NO LED EOL + Series	SWITCH TYPE [s] [D] TERMINALS [t] [D] PRODUCT OPTION [o] [Y] LED INDICATOR [u] [N] MODULES [e][s] [Exxxx][Sxxxx]	Dual DIN Rail Only Alt. EOL Pos'n. DUP. NO LED EOL + Series

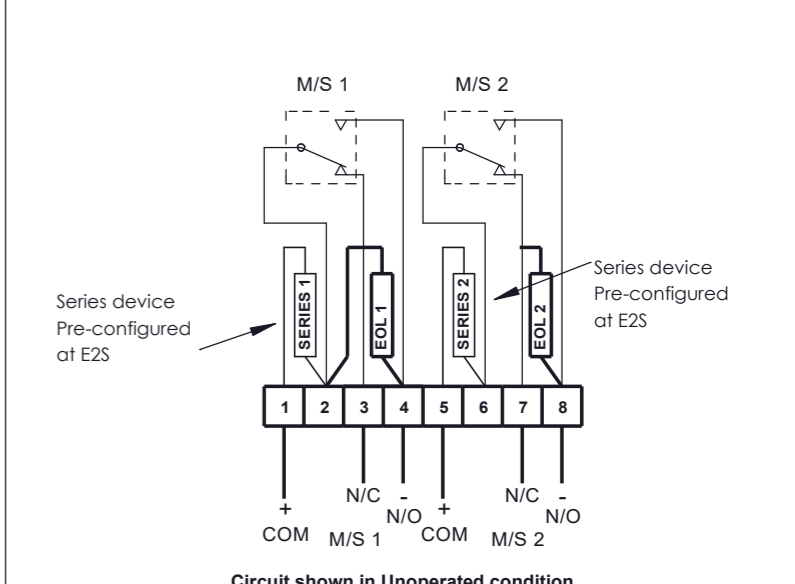
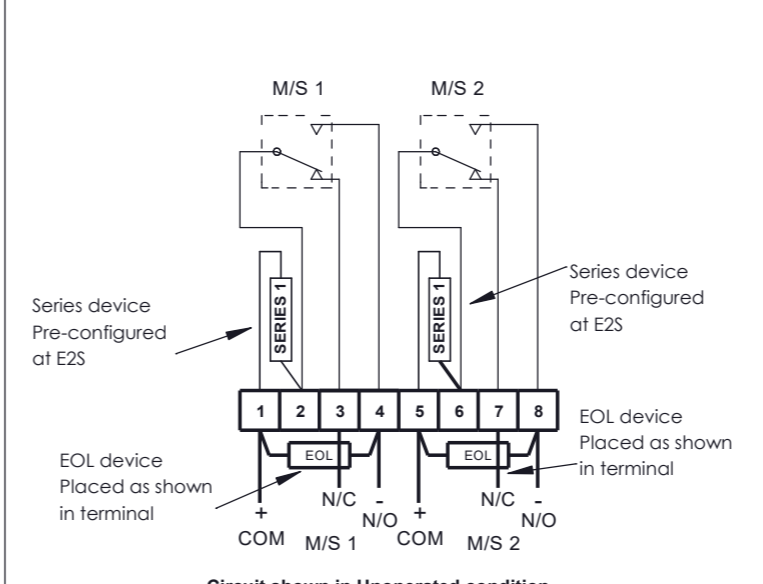
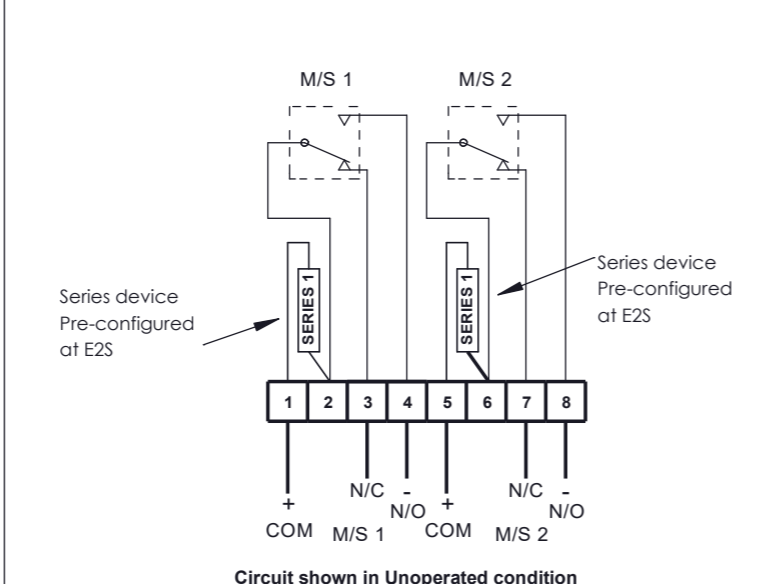
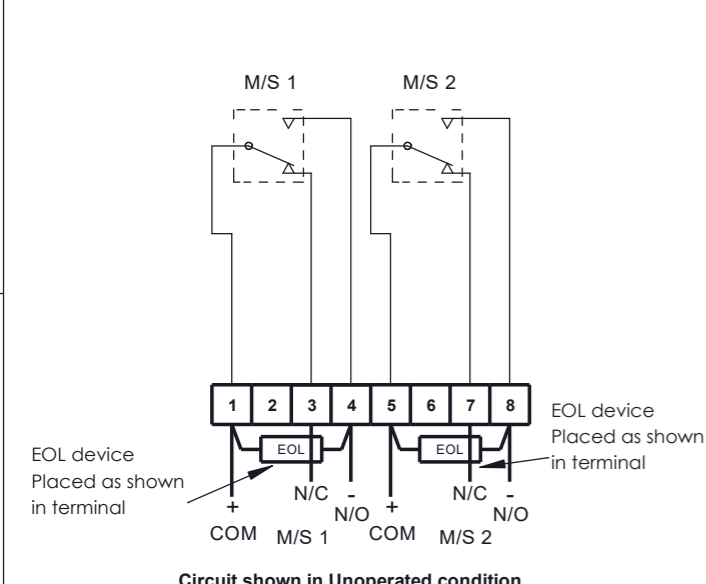
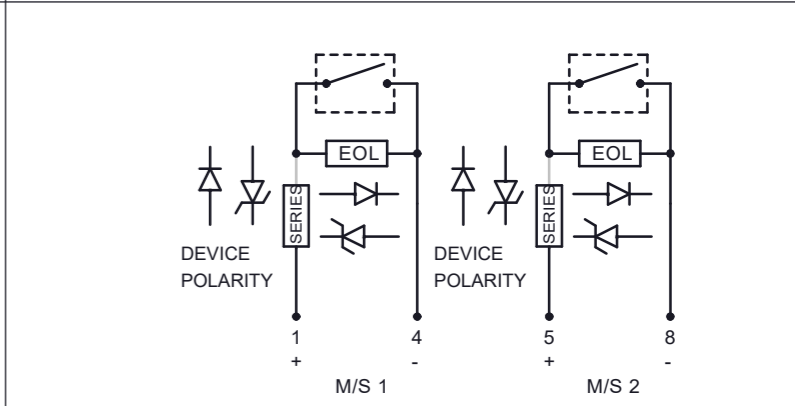
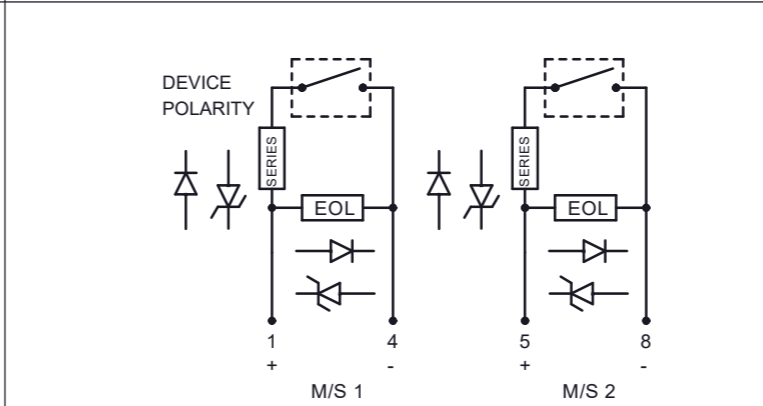
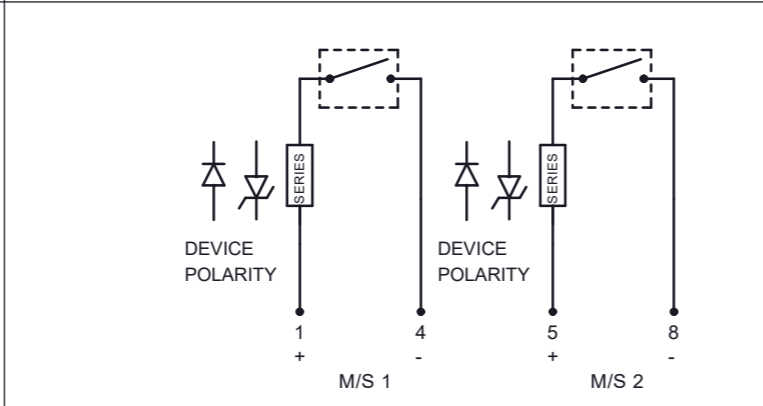
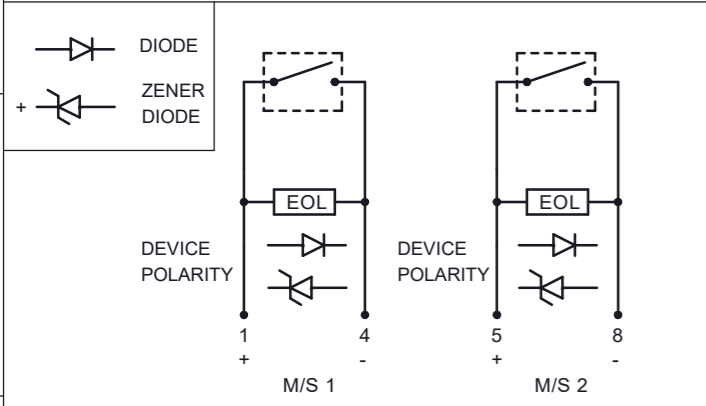

**Circuit shown in Unoperated condition**

**Unoperated condition (Glass Intact / Standby Condition)**  
 Terminals +(1) & -(4) M/S 1 & +(5) & -(8) M/S 2 open  
 Terminals +(1) & -(3) M/S 1 & +(5) & -(7) M/S 2 closed

**Operated condition (Glass Broken / Button pushed in)**  
 Terminals +(1) & -(3) M/S 1 & +(5) & -(7) M/S 2 open  
 Terminals +(1) & -(4) M/S 1 & +(5) & -(8) M/S 2 closed

**Circuit shown in Unoperated condition**

**Unoperated condition (Glass Intact / Standby Condition)**  
 Terminals +(1) & -(4) M/S 1 & +(5) & -(8) M/S 2 open  
 Terminals +(1) & -(3) M/S 1 & +(5) & -(7) M/S 2 closed

**Operated condition (Glass Broken / Button pushed in)**  
 Terminals +(1) & -(3) M/S 1 & +(5) & -(7) M/S 2 open  
 Terminals +(1) & -(4) M/S 1 & +(5) & -(8) M/S 2 closed

**Circuit shown in Unoperated condition**

**Unoperated condition (Glass Intact / Standby Condition)**  
 Terminals +(1) & -(4) M/S 1 & +(5) & -(8) M/S 2 open  
 Terminals +(1) & -(3) M/S 1 & +(5) & -(7) M/S 2 closed

**Operated condition (Glass Broken / Button pushed in)**  
 Terminals +(1) & -(3) M/S 1 & +(5) & -(7) M/S 2 open  
 Terminals +(1) & -(4) M/S 1 & +(5) & -(8) M/S 2 closed

**Circuit shown in Unoperated condition**

**Unoperated condition (Glass Intact / Standby Condition)**  
 Terminals +(1) & -(4) M/S 1 & +(5) & -(8) M/S 2 open  
 Terminals +(1) & -(3) M/S 1 & +(5) & -(7) M/S 2 closed

**Operated condition (Glass Broken / Button pushed in)**  
 Terminals +(1) & -(3) M/S 1 & +(5) & -(7) M/S 2 open  
 Terminals +(1) & -(4) M/S 1 & +(5) & -(8) M/S 2 closed

DRAWING TO BS8888:2000  
 GEOMETRIC TOLERANCES TO ISO1101:1983  
 LINEAR DIMENSIONAL TOLS  
 ANGULAR DIMENSIONAL TOLS

STANDARDS  
**GNExCP7 ; STExCP8 ; WP7 units with DIN Rail**

DRAWN DATE  
**D.HOWGILL 05-03-2020**

CHECKED DATE  
**R.N.POTTS 05-03-2020**

APPROVED DATE  
**R.N.POTTS 05-03-2020**

SURFACE FINISH WEIGHT (Kg)

MATERIAL

ALTERNATIVE MATERIAL

THIS DRAWING AND ANY INFORMATION OR DESCRIPTIVE MATTER THEREIN IS COMMUNICATED IN CONFIDENCE AND IS THE COPYRIGHT PROPERTY OF EUROPEAN SAFETY SYSTEMS LTD. NEITHER THE WHOLE OR ANY EXTRACT MAY BE DISCLOSED, LOANED, COPIED OR USED FOR MANUFACTURING OR TENDERING PURPOSES WITHOUT THEIR WRITTEN CONSENT.

EUROPEAN SAFETY SYSTEMS LTD.  
 AS PER LATEST DATE OF ISSUE SHOWN ABOVE



ALL DIMENSIONS IN MM  
 IF IN DOUBT, ASK - DO NOT SCALE

TITLE **GNExCP7 ; STExCP8 ; WP7 CALL POINT WIRING / CIRCUIT OPERATION DIAGRAM**

SCALE SHEET DRAWING NUMBER  
**NTS 3 OF 8 D202-06-211**

**SINGLE MICROSWITCH LED DEVICES**

**SHEET 4**

GNEXCP7-BG[s][t][l][e][m][d][v][o][x][u]-[v][e][s] Series  
 Switch Type [s] Terminals [t] Product Version [v] Product Option [o] LED Indicator [u] EOL Module [e]

Module Device Codes		
	EOL	Series
Resistor	ExxxR	SxxxR
Diode	ED1	SD1
Zener Diode	ExxxZ	SxxxZ
LED	N/A	L or C

ISSUE	MOD No.	REASON - INITIAL - DATE
5	ACN0102	Addition of BG version ; Options clarified RNP 15-04-2022
6	ACN0127	Configuration coding added and aligned with other call points. LED options added ; PCB page moved to new document. RNP 14-07-2023

Notes:  
 1. Units have the option to remove the LED current-limiting resistor RL1 option 'L' using LED option 'C'. In all other cases shown RL1 is included.

SINGLE SWITCH WITH LED ONLY	CONFIG. D4-1	SINGLE SWITCH WITH LED & EOL DEVICE	CONFIG. D4-2	SINGLE SWITCH WITH LED EOL & SERIES DEVICES	CONFIG. D4-3	SINGLE SWITCH WITH LED, EOL & ALT. SERIES DEVICE	CONFIG. D4-4
-----------------------------	--------------	-------------------------------------	--------------	---	--------------	--	--------------

SWITCH TYPE [s] [S] TERMINALS [t] [D] PRODUCT OPTION [o] [1] LED INDICATOR [u] [L]	Single DIN Rail Default LED with RL1	SWITCH TYPE [s] [S] TERMINALS [t] [D] PRODUCT OPTION [o] [1] LED INDICATOR [u] [L] SERIES MODULE [e] [Exxxx]	Single DIN Rail Default LED with RL1 EOL Device	SWITCH TYPE [s] [S] TERMINALS [t] [D] PRODUCT OPTION [o] [1] LED INDICATOR [u] [L] EOL MODULE [e][s] [Exxxx][Sxxxx]	Single DIN Rail Default LED with RL1 EOL + Series Device	SWITCH TYPE [s] [S] TERMINALS [t] [D] PRODUCT OPTION [o] [W] LED INDICATOR [u] [L] MODULES [e][s] [Exxxx][Sxxxx]	Single DIN Rail Alt. EOL Pos'n. LED with RL1 EOL + Series Device
---	---	--	---	---	--	--	--

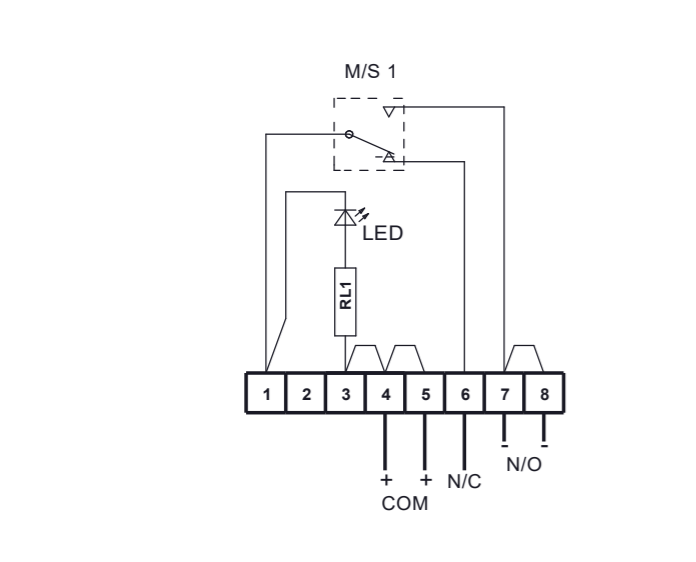
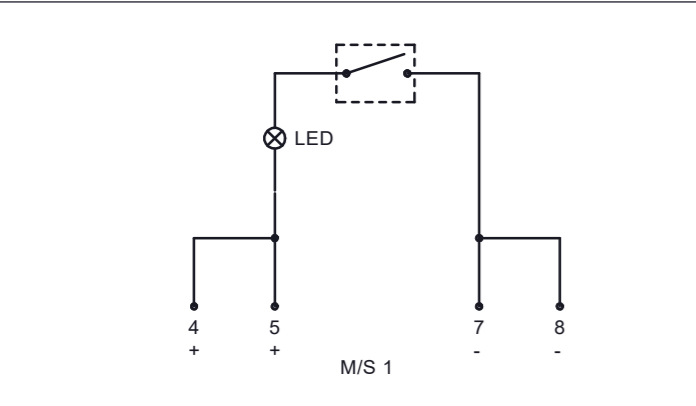

**Circuit shown in Unoperated condition**

**Unoperated condition (Glass Intact / Standby Condition)**  
 Terminals +(4,5) & -(7,8) open  
 Terminals +(4,5) & (6) closed

**Operated condition (Glass Broken / Button pushed in)**  
 Terminals +(4,5) & -(7,8) closed  
 Terminals +(4,5) & (6) open

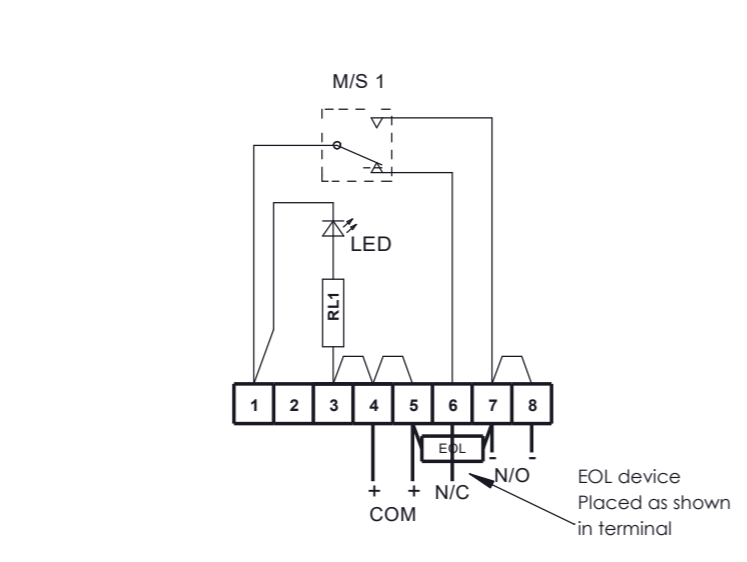
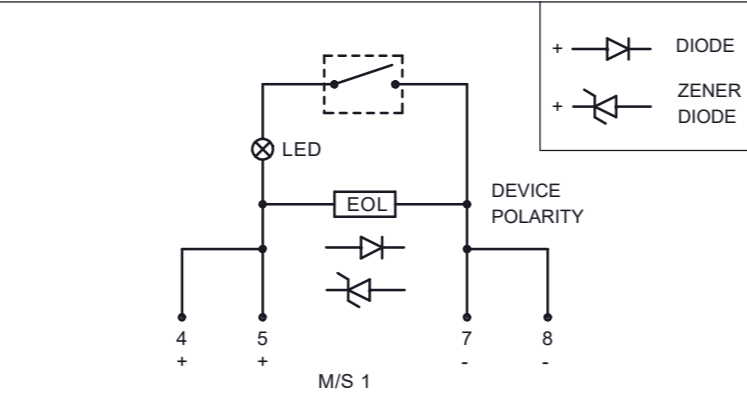

**Circuit shown in Unoperated condition**

**Unoperated condition (Glass Intact / Standby Condition)**  
 Terminals +(4,5) & -(7,8) open  
 Terminals +(4,5) & (6) closed

**Operated condition (Glass Broken / Button pushed in)**  
 Terminals +(4,5) & -(7,8) closed  
 Terminals +(4,5) & (6) open

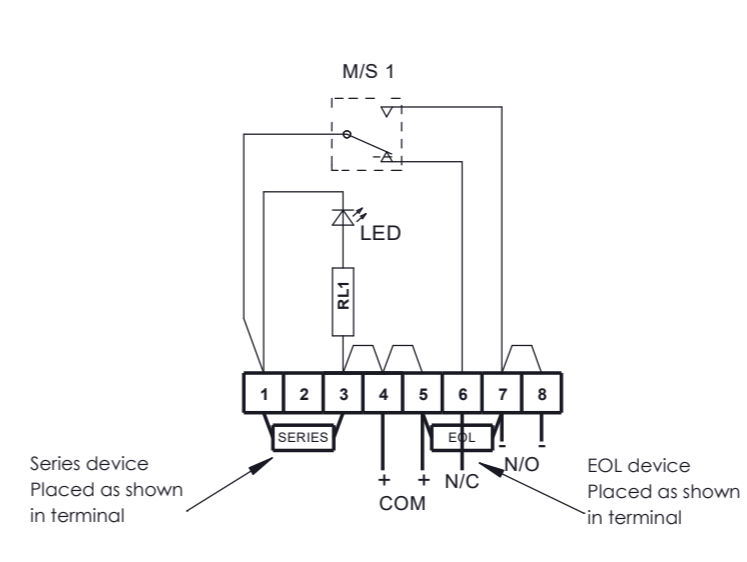
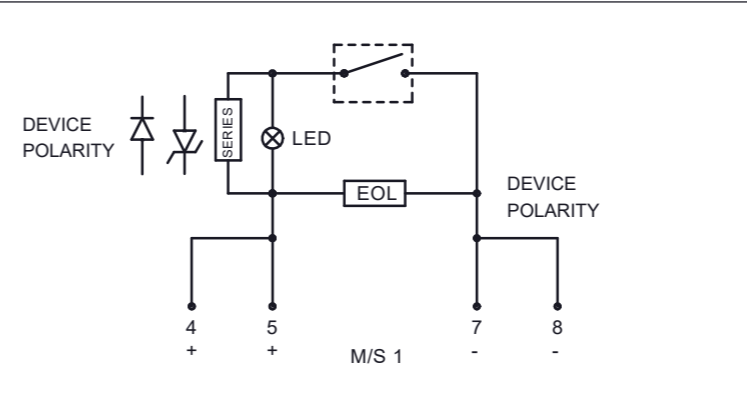

**Circuit shown in Unoperated condition**

**Unoperated condition (Glass Intact / Standby Condition)**  
 Terminals +(4,5) & -(7,8) open  
 Terminals +(4,5) & (6) closed

**Operated condition (Glass Broken / Button pushed in)**  
 Terminals +(4,5) & -(7,8) closed  
 Terminals +(4,5) & (6) open

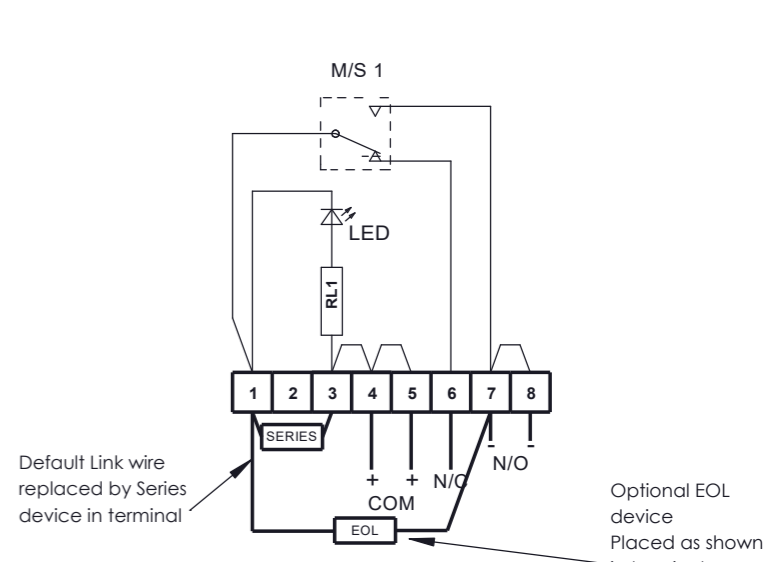
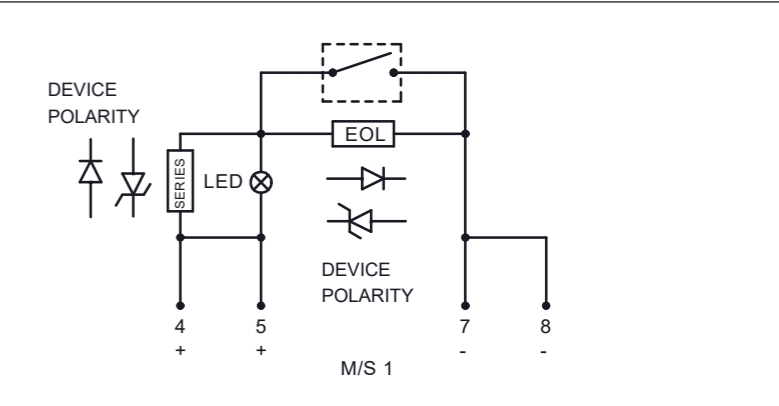

**Circuit shown in Unoperated condition**

**Unoperated condition (Glass Intact / Standby Condition)**  
 Terminals +(4,5) & -(7,8) open  
 Terminals +(4,5) & (6) closed

**Operated condition (Glass Broken / Button pushed in)**  
 Terminals +(4,5) & -(7,8) closed  
 Terminals +(4,5) & (6) open

DRAWING TO BS8888:2000  
 GEOMETRIC TOLERANCES TO ISO1101:1983  
 LINEAR DIMENSIONAL TOLS  
 ANGULAR DIMENSIONAL TOLS

STANDARDS  
**GNExCP7 ; STExCP8 ; WP7 units with DIN Rail**

DRAWN	DATE
D.HOWGILL	05-03-2020
CHECKED	DATE
R.N.POTTS	05-03-2020
APPROVED	DATE
R.N.POTTS	05-03-2020

SURFACE FINISH	WEIGHT (Kg)
MATERIAL	
ALTERNATIVE MATERIAL	

THIS DRAWING AND ANY INFORMATION OR DESCRIPTIVE MATTER THEREIN IS COMMUNICATED IN CONFIDENCE AND IS THE COPYRIGHT PROPERTY OF EUROPEAN SAFETY SYSTEMS LTD. NEITHER THE WHOLE OR ANY EXTRACT MAY BE DISCLOSED, LOANED, COPIED OR USED FOR MANUFACTURING OR TENDERING PURPOSES WITHOUT THEIR WRITTEN CONSENT.

EUROPEAN SAFETY SYSTEMS LTD.  
 AS PER LATEST DATE OF ISSUE SHOWN ABOVE

EUROPEAN SAFETY SYSTEMS LTD  
 IMPRESS HOUSE  
 MANSELL ROAD  
 ACTON  
 LONDON W3 7QH  
 WWW.E2S.COM

ALL DIMENSIONS IN MM IF IN DOUBT, ASK - DO NOT SCALE				<b>A3</b>
TITLE <b>GNExCP7 ; STExCP8 ; WP7 CALL POINT WIRING / CIRCUIT OPERATION DIAGRAM</b>				
SCALE	SHEET	DRAWING NUMBER		
NTS	4 OF 8	<b>D202-06-211</b>		

**DUAL MICROSWITCH LED DEVICES**

**SHEET 5**

Notes:  
1. Units have the option to remove the LED current-limiting resistor RL1 option 'L' using LED option 'C'. In all other cases shown RL1 is included.

GNEXCP7-BG[s][t][l][e][m][d][v][o][x][u]-[v][e][s] Series  
 Switch Type [s] Terminals [t] Product Version [v] Product Option [o] LED Indicator [u] EOL Module [e]

Module Device Codes		
	EOL	Series
Resistor	ExxxR	SxxxR
Diode	ED1	SD1
Zener Diode	ExxxZ	SxxxZ
LED	N/A	L or C

ISSUE	MOD No.	REASON - INITIAL - DATE
5	ACN0102	Addition of BG version ; Options clarified RNP 15-04-2022
6	ACN0127	Configuration coding added and aligned with other call points. LED options added ; PCB page moved to new document. RNP 14-07-2023

DUAL SWITCH WITH LED	CONFIG. D5-1	DUAL SWITCH WITH LED & EOL DEVICES	CONFIG. D5-2	DUAL SWITCH WITH LED EOL & SERIES DEVICES	CONFIG. D5-3	DUAL SWITCH WITH LED, EOL & ALT. SERIES DEVICE	CONFIG. D5-4
----------------------	--------------	------------------------------------	--------------	---	--------------	--	--------------

SWITCH TYPE [s] TERMINALS [t] PRODUCT OPTION [o] LED INDICATOR [u]	[D] Dual [D] DIN Rail Only [1] Default [L] LED with RL1	SWITCH TYPE [s] TERMINALS [t] PRODUCT OPTION [o] LED INDICATOR [u] EOL MODULE [e]	[D] Dual [D] DIN Rail Only [1] Default [L] LED with RL1 [ExxxR] EOL Device	SWITCH TYPE [s] TERMINALS [t] PRODUCT OPTION [o] LED INDICATOR [u] SERIES MODULE [s]	[D] Dual [D] DIN Rail Only [1] Default [L] LED with RL1 [Sxxxx] Series Device	SWITCH TYPE [s] TERMINALS [t] PRODUCT OPTION [o] LED INDICATOR [u] MODULES [e][s]	[D] Dual [D] DIN Rail Only [W] Alt. EOL Pos'n. [L] LED with RL1 [Exxxx][Sxxxx] EOL + Series
---	--	---	--	--	---	---	---

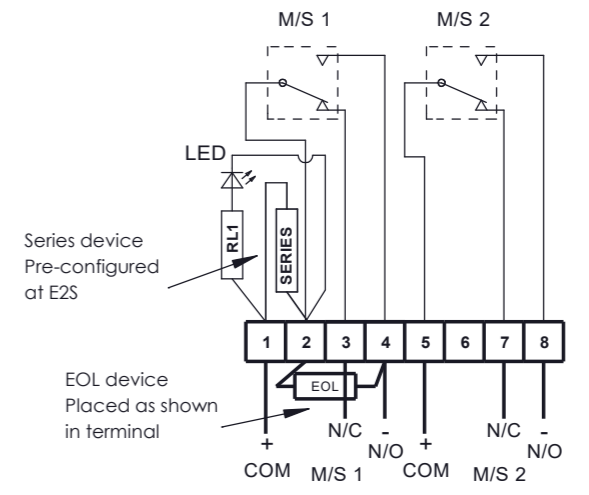
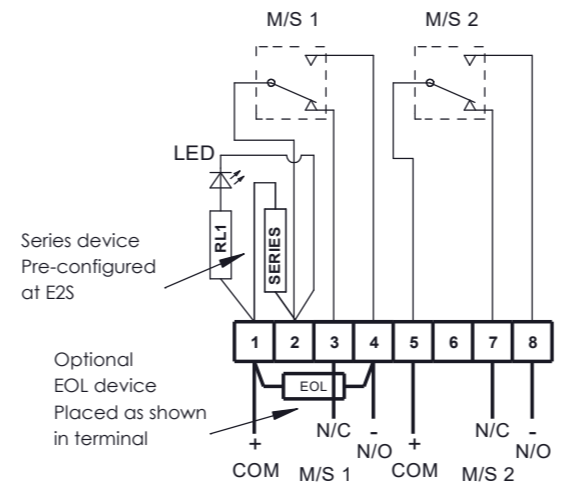
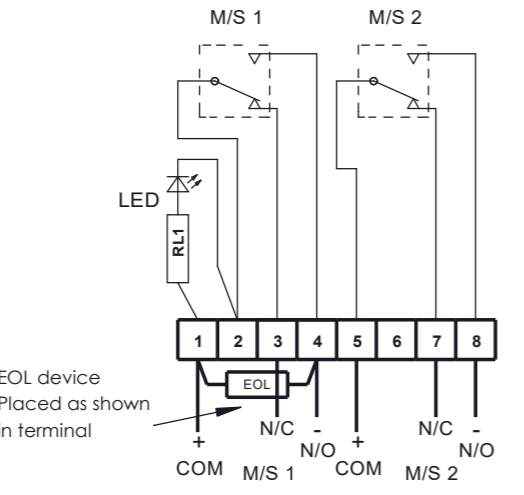
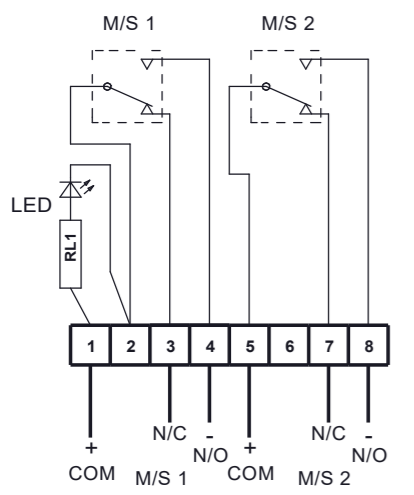
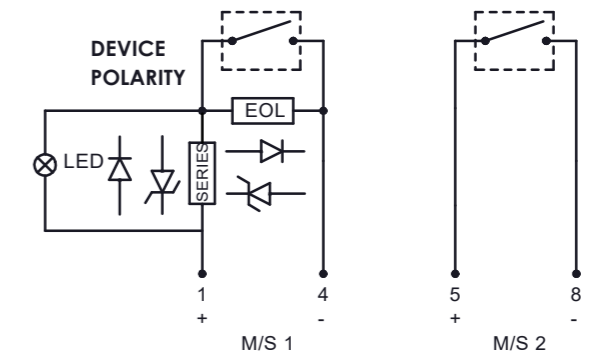
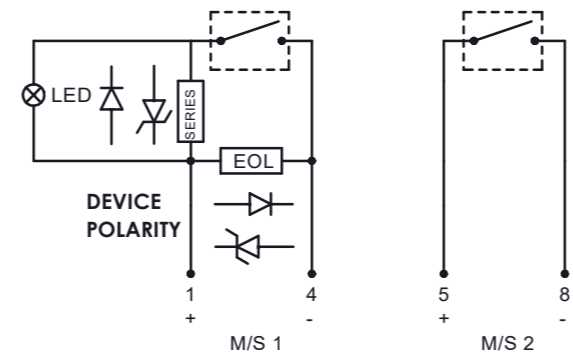
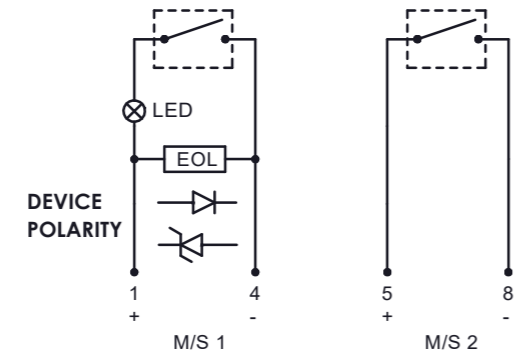
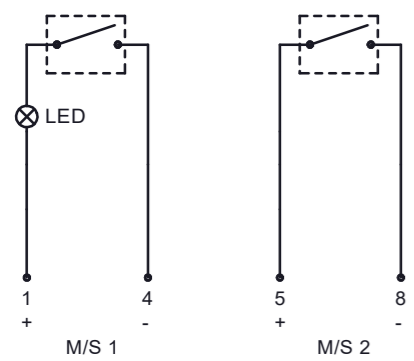

**Circuit shown in Unoperated condition**

**Unoperated condition (Glass Intact / Standby Condition)**  
 Terminals +(1) & -(4) M/S 1 & +(5) & -(8) M/S 2 open  
 Terminals +(1) & -(3) M/S 1 & +(5) & -(7) M/S 2 closed

**Operated condition (Glass Broken / Button pushed in)**  
 Terminals +(1) & -(3) M/S 1 & +(5) & -(7) M/S 2 open  
 Terminals +(1) & -(4) M/S 1 & +(5) & -(8) M/S 2 closed

**Circuit shown in Unoperated condition**

**Unoperated condition (Glass Intact / Standby Condition)**  
 Terminals +(1) & -(4) M/S 1 & +(5) & -(8) M/S 2 open  
 Terminals +(1) & -(3) M/S 1 & +(5) & -(7) M/S 2 closed

**Operated condition (Glass Broken / Button pushed in)**  
 Terminals +(1) & -(3) M/S 1 & +(5) & -(7) M/S 2 open  
 Terminals +(1) & -(4) M/S 1 & +(5) & -(8) M/S 2 closed

**Circuit shown in Unoperated condition**

**Unoperated condition (Glass Intact / Standby Condition)**  
 Terminals +(1) & -(4) M/S 1 & +(5) & -(8) M/S 2 open  
 Terminals +(1) & -(3) M/S 1 & +(5) & -(7) M/S 2 closed

**Operated condition (Glass Broken / Button pushed in)**  
 Terminals +(1) & -(3) M/S 1 & +(5) & -(7) M/S 2 open  
 Terminals +(1) & -(4) M/S 1 & +(5) & -(8) M/S 2 closed

**Circuit shown in Unoperated condition**

**Unoperated condition (Glass Intact / Standby Condition)**  
 Terminals +(1) & -(4) M/S 1 & +(5) & -(8) M/S 2 open  
 Terminals +(1) & -(3) M/S 1 & +(5) & -(7) M/S 2 closed

**Operated condition (Glass Broken / Button pushed in)**  
 Terminals +(1) & -(3) M/S 1 & +(5) & -(7) M/S 2 open  
 Terminals +(1) & -(4) M/S 1 & +(5) & -(8) M/S 2 closed

DRAWING TO BS8888:2000  
 GEOMETRIC TOLERANCES TO ISO1101:1983  
 LINEAR DIMENSIONAL TOLS  
 ANGULAR DIMENSIONAL TOLS

STANDARDS

DRAWN	DATE
D.HOWGILL	05-03-2020
CHECKED	DATE
R.N.POTTS	05-03-2020
APPROVED	DATE
R.N.POTTS	05-03-2020

SURFACE FINISH	WEIGHT (Kg)
MATERIAL	
ALTERNATIVE MATERIAL	

THIS DRAWING AND ANY INFORMATION OR DESCRIPTIVE MATTER THEREIN IS COMMUNICATED IN CONFIDENCE AND IS THE COPYRIGHT PROPERTY OF EUROPEAN SAFETY SYSTEMS LTD. NEITHER THE WHOLE OR ANY EXTRACT MAY BE DISCLOSED, LOANED, COPIED OR USED FOR MANUFACTURING OR TENDERING PURPOSES WITHOUT THEIR WRITTEN CONSENT.

EUROPEAN SAFETY SYSTEMS LTD.  
 AS PER LATEST DATE OF ISSUE SHOWN ABOVE

**e2S**  
 warning signals

EUROPEAN SAFETY SYSTEMS LTD  
 IMPRESS HOUSE  
 MANSELL ROAD  
 ACTON  
 LONDON W3 7QH  
 WWW.E2S.COM

ALL DIMENSIONS IN MM  
 IF IN DOUBT, ASK - DO NOT SCALE

TITLE **GNEXCP7 ; STEXCP8 ; WP7 CALL POINT WIRING / CIRCUIT OPERATION DIAGRAM**

SCALE	SHEET	DRAWING NUMBER
NTS	5 OF 8	<b>D202-06-211</b>

<b>DUAL SWITCH WITH LED &amp; EOL DEVICE</b>	<b>CONFIG. D6-1</b>	<b>DUAL SWITCH WITH LED &amp; SERIES DEVICE</b>	<b>CONFIG. D6-2</b>	<b>DUAL SWITCH WITH LED, EOL &amp; SERIES DEVICE</b>	<b>CONFIG. D6-3</b>
SWITCH TYPE [s] [D] Dual TERMINALS [t] [D] DIN Rail Only PRODUCT OPTION [o] [2] Duplicated EOL LED INDICATOR [u] [L] LED with RL1 EOL MODULE [e] [ExxxR] EOL Device		SWITCH TYPE [s] [D] Dual TERMINALS [t] [D] DIN Rail Only PRODUCT OPTION [o] [2] Duplicated EOL / SERIES LED INDICATOR [u] [L] LED with RL1 SERIES MODULE [s] [Sxxxx] Series Device		SWITCH TYPE [s] [D] Dual TERMINALS [t] [D] DIN Rail Only PRODUCT OPTION [o] [Y] Alt. EOL Pos'n. DUPLICATED LED INDICATOR [u] [L] LED with RL1 MODULES [e][s] [Exxxx][Sxxxx] EOL + Series	

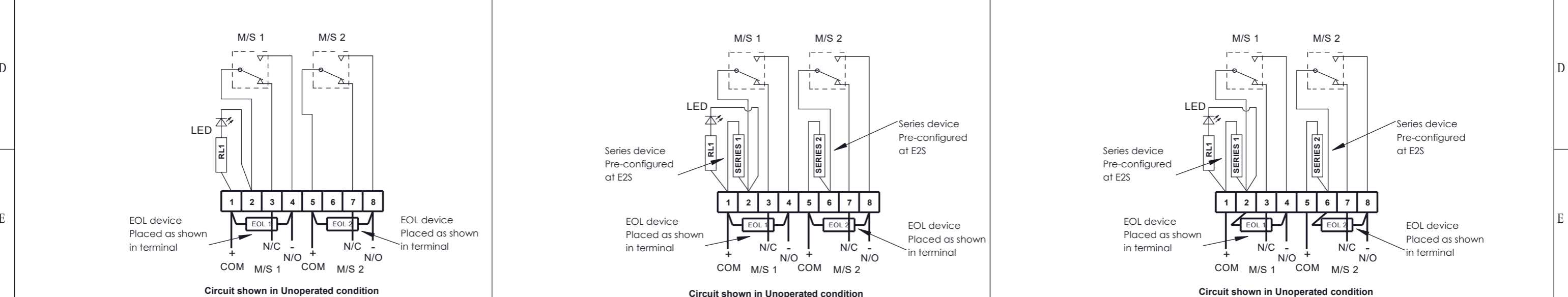
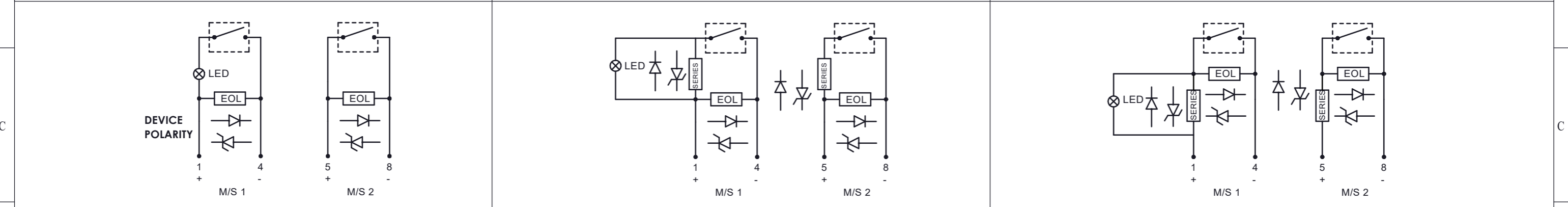

**Circuit shown in Unoperated condition**

**Unoperated condition (Glass Intact / Standby Condition)**  
 Terminals +(1) & -(4) M/S 1 & +(5) & -(8) M/S 2 open  
 Terminals +(1) & -(3) M/S 1 & +(5) & -(7) M/S 2 closed

**Operated condition (Glass Broken / Button pushed in)**  
 Terminals +(1) & -(3) M/S 1 & +(5) & -(7) M/S 2 open  
 Terminals +(1) & -(4) M/S 1 & +(5) & -(8) M/S 2 closed

# DUAL MICROSWITCHES IN PARALLEL

# SHEET 7

Notes:  
1. Other configurations of dual switch units are possible. Contact E2S sales to discuss options.

GNEXCP7-BG[s][t][l][e][m][d][v][o][x][u]-[v][e][s] Series  
 Switch Type [s] Terminals [t] Product Version [v] Product Option [o] LED Indicator [u] EOL Module [e]

Module Device Codes		
	EOL	Series
Resistor	ExxxR	SxxxR
Diode	ED1	SD1
Zener Diode	ExxxZ	SxxxZ
LED	N/A	L or C

ISSUE	MOD No.	REASON - INITIAL - DATE
5	ACN0102	Addition of BG version ; Options clarified RNP 15-04-2022
6	ACN0127	Configuration coding added and aligned with other call points. LED options added ; PCB page moved to new document. RNP 14-07-2023

DUAL SWITCH WITH EOL DEVICE	CONFIG. D7-1	DUAL SWITCH WITH SERIES DEVICES	CONFIG. D7-2	DUAL SWITCH WITH EOL & SERIES DEVICE	CONFIG. D7-3	DUAL SWITCH WITH EOL & SERIES DEVICE	CONFIG. D7-4
SWITCH TYPE [s] [D] TERMINALS [t] [D] PRODUCT OPTION [o] [P] LED INDICATOR [u] [N]	Dual DIN Rail Parallel Wiring No LED	SWITCH TYPE [s] [D] TERMINALS [t] [D] PRODUCT OPTION [o] [P] LED INDICATOR [u] [N] SERIES MODULE [s] [Sxxxx]	Dual DIN Rail Parallel Wiring No LED Series Device	SWITCH TYPE [s] [D] TERMINALS [t] [D] PRODUCT OPTION [o] [P] LED INDICATOR [u] [N] MODULE [e][s] [Exxxx][Sxxxx]	Dual DIN Rail Parallel Wiring No LED EOL & Series Device	SWITCH TYPE [s] [D] TERMINALS [t] [D] PRODUCT OPTION [o] [V] LED INDICATOR [u] [N] MODULE [e][s] [Exxxx][Sxxxx]	Dual DIN Rail Only Alt. EOL Pos'n No LED EOL & Series Devices

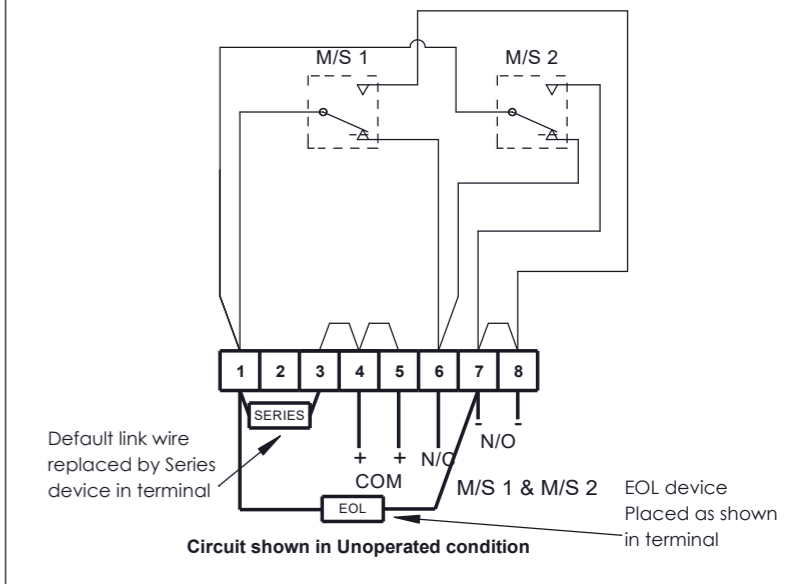
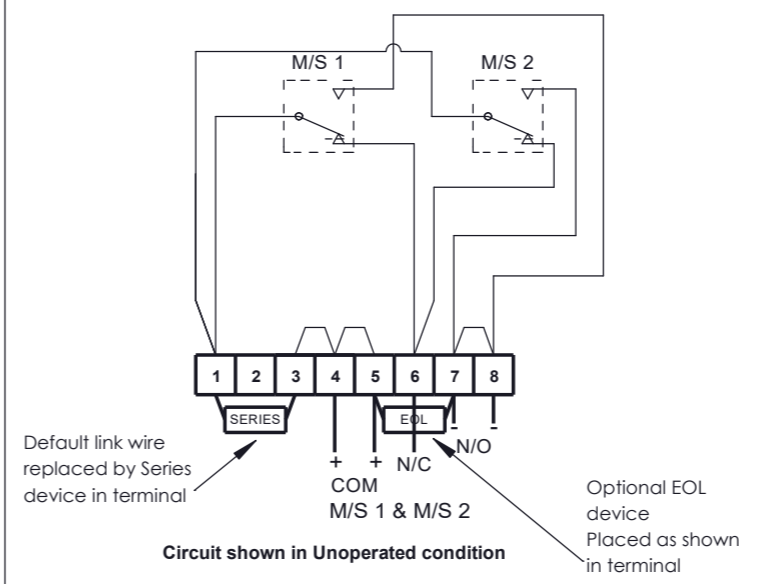
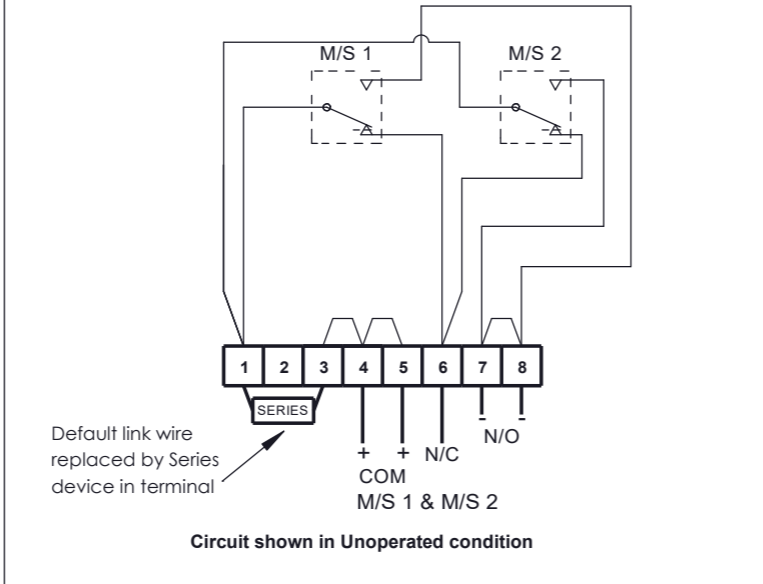
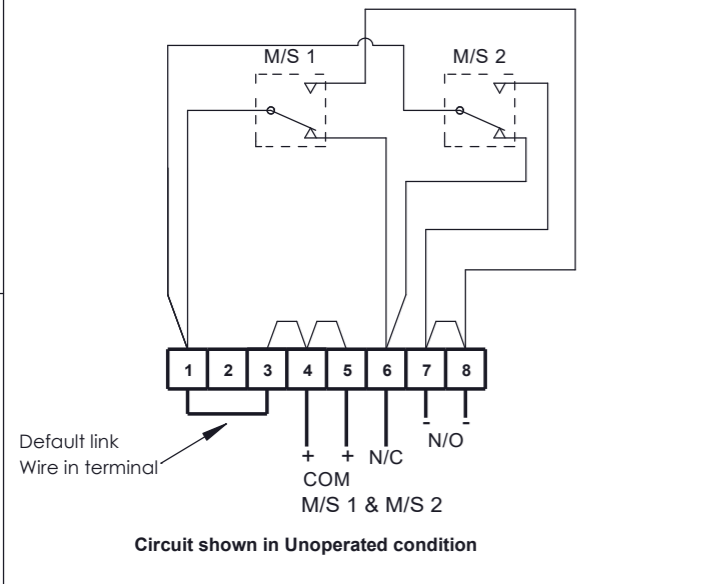
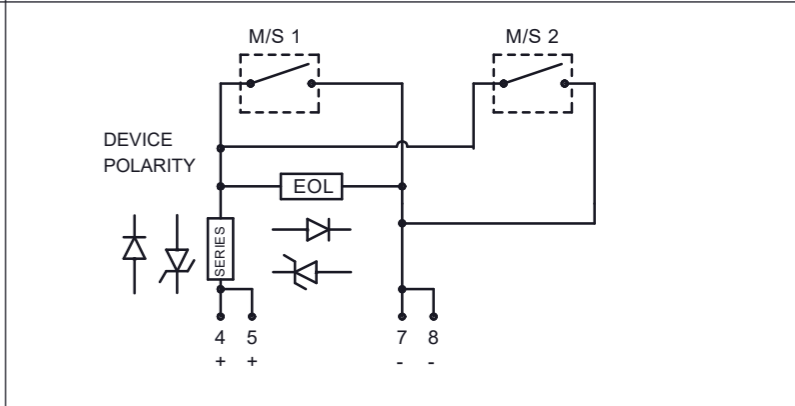
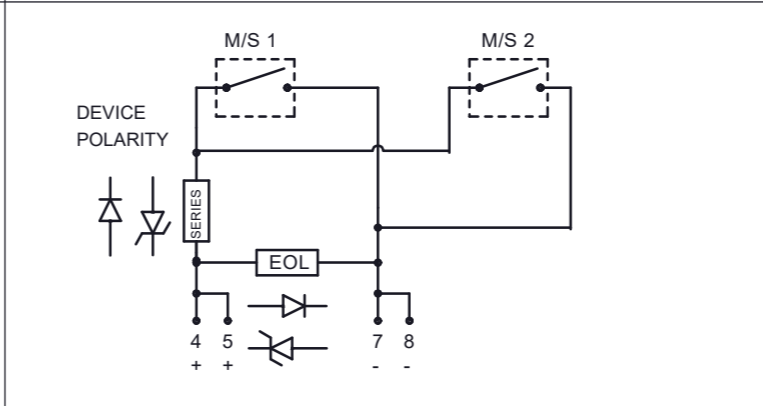
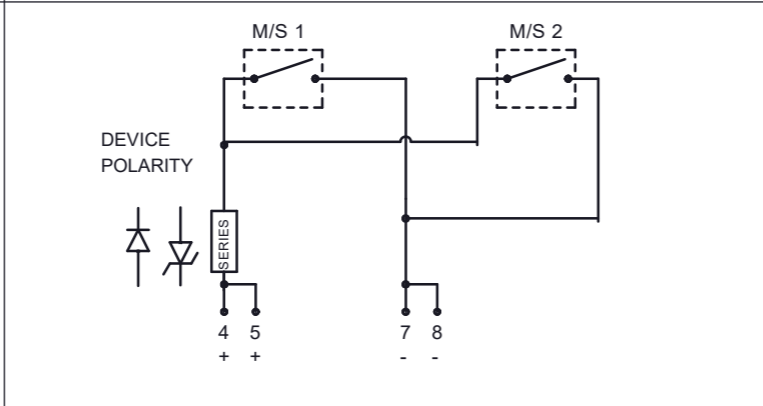
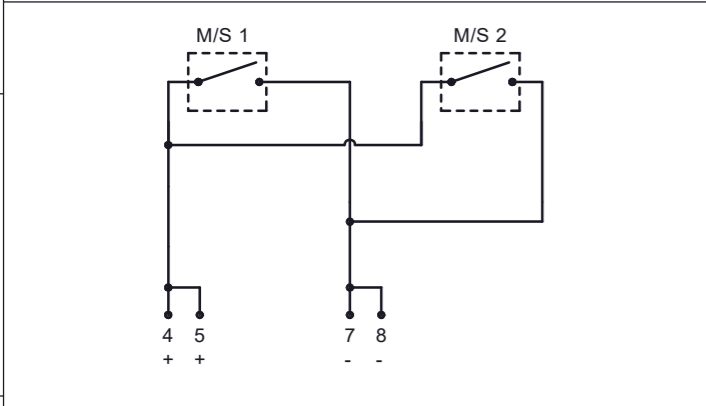

**Circuit shown in Unoperated condition**

**Unoperated condition (Glass Intact / Standby Condition)**  
 Terminals +(4,5) & -(7,8) open  
 Terminals +(4,5) & (6) closed

**Operated condition (Glass Broken / Button pushed in)**  
 Terminals +(4,5) & -(7,8) closed  
 Terminals +(4,5) & (6) open

**Circuit shown in Unoperated condition**

**Unoperated condition (Glass Intact / Standby Condition)**  
 Terminals +(4,5) & -(7,8) open  
 Terminals +(4,5) & (6) closed

**Operated condition (Glass Broken / Button pushed in)**  
 Terminals +(4,5) & -(7,8) closed  
 Terminals +(4,5) & (6) open

**Circuit shown in Unoperated condition**

**Unoperated condition (Glass Intact / Standby Condition)**  
 Terminals +(4,5) & -(7,8) open  
 Terminals +(4,5) & (6) closed

**Operated condition (Glass Broken / Button pushed in)**  
 Terminals +(4,5) & -(7,8) closed  
 Terminals +(4,5) & (6) open

**Circuit shown in Unoperated condition**

**Unoperated condition (Glass Intact / Standby Condition)**  
 Terminals +(4,5) & -(7,8) open  
 Terminals +(4,5) & (6) closed

**Operated condition (Glass Broken / Button pushed in)**  
 Terminals +(4,5) & -(7,8) closed  
 Terminals +(4,5) & (6) open

DRAWING TO BS8888:2000  
 GEOMETRIC TOLERANCES TO ISO1101:1983  
 LINEAR DIMENSIONAL TOLS  
 ANGULAR DIMENSIONAL TOLS

STANDARDS  
**GNEXCP7 ; STEXCP8 ; WP7 units with DIN Rail**

DRAWN	DATE
D.HOWGILL	05-03-2020
CHECKED	DATE
R.N.POTTS	05-03-2020
APPROVED	DATE
R.N.POTTS	05-03-2020

SURFACE FINISH	WEIGHT (Kg)
MATERIAL	
ALTERNATIVE MATERIAL	

THIS DRAWING AND ANY INFORMATION OR DESCRIPTIVE MATTER THEREIN IS COMMUNICATED IN CONFIDENCE AND IS THE COPYRIGHT PROPERTY OF EUROPEAN SAFETY SYSTEMS LTD. NEITHER THE WHOLE OR ANY EXTRACT MAY BE DISCLOSED, LOANED, COPIED OR USED FOR MANUFACTURING OR TENDERING PURPOSES WITHOUT THEIR WRITTEN CONSENT.

© EUROPEAN SAFETY SYSTEMS LTD. AS PER LATEST DATE OF ISSUE SHOWN ABOVE



ALL DIMENSIONS IN MM  
 IF IN DOUBT, ASK - DO NOT SCALE

TITLE **GNEXCP7 ; STEXCP8 ; WP7 CALL POINT WIRING / CIRCUIT OPERATION DIAGRAM**

SCALE	SHEET	DRAWING NUMBER
NTS	7 OF 8	<b>D202-06-211</b>

**DUAL MICROSWITCHES IN PARALLEL, LED & DEVICES**

**SHEET 8**

Notes:  
1. Units have the option to remove the LED current-limiting resistor RL1 option 'L' using LED option 'C'. In all other cases shown RL1 is included.

GNEXCP7-BG[s][t][l][e][m][d][v][o][x][u]-[v][e][s] Series  
 Switch Type [s] Terminals [t] Product Version [v] Product Option [o] LED Indicator [u] EOL Module [e]

Module Device Codes		
	EOL	Series
Resistor	ExxxR	SxxxR
Diode	ED1	SD1
Zener Diode	ExxxZ	SxxxZ
LED	N/A	L or C

ISSUE	MOD No.	REASON - INITIAL - DATE
5	ACN0102	Addition of BG version : Options clarified RNP 15-04-2022
6	ACN0127	Configuration coding added and aligned with other call points. LED options added : PCB page moved to new document. RNP 14-07-2023

DUAL SWITCH WITH LED	CONFIG. D8-1	DUAL SWITCH WITH LED & EOL DEVICE	CONFIG. D8-2	DUAL SWITCH WITH EOL & SERIES DEVICE	CONFIG. D8-3	DUAL SWITCH WITH EOL & SERIES DEVICE	CONFIG. D8-4
----------------------	--------------	-----------------------------------	--------------	--------------------------------------	--------------	--------------------------------------	--------------

SWITCH TYPE [s] [D] TERMINALS [t] [D] PRODUCT OPTION [o] [P] LED INDICATOR [u] [L]	Dual DIN Rail Parallel Wiring LED with RL1	SWITCH TYPE [s] [D] TERMINALS [t] [D] PRODUCT OPTION [o] [P] LED INDICATOR [u] [L] EOL MODULE [e] [Exxxx]	Dual DIN Rail Parallel Wiring LED with RL1 EOL Device	SWITCH TYPE [s] [D] TERMINALS [t] [D] PRODUCT OPTION [o] [P] LED INDICATOR [u] [L] MODULE [e][s] [Exxxx][Sxxxx]	Dual DIN Rail Only Parallel Wiring LED with RL1 EOL + Series	SWITCH TYPE [s] [D] TERMINALS [t] [D] PRODUCT OPTION [o] [V] LED INDICATOR [u] [L] MODULE [e][s] [Exxxx][Sxxxx]	Dual DIN Rail Only Parallel Wiring Alt. EOL LED with RL1 EOL + Series
---	---	---	---	---	--	---	---

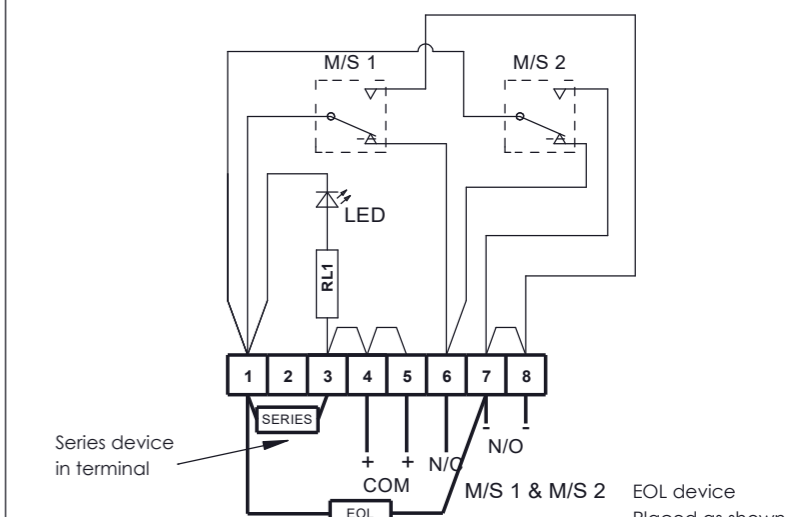
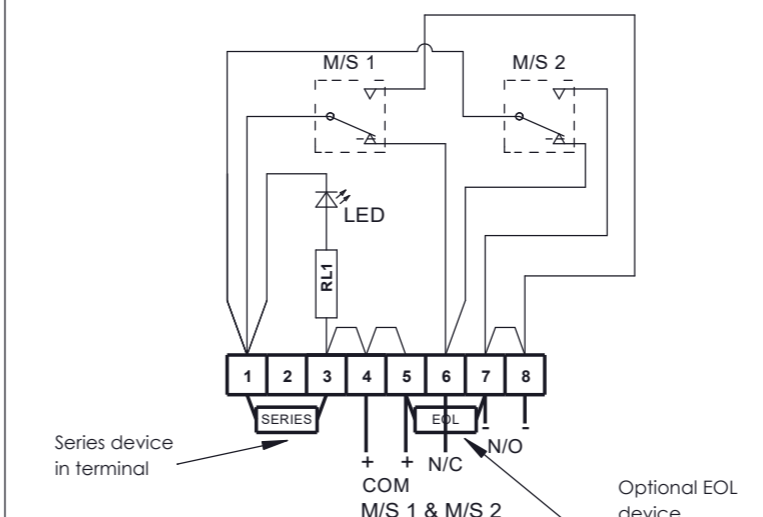
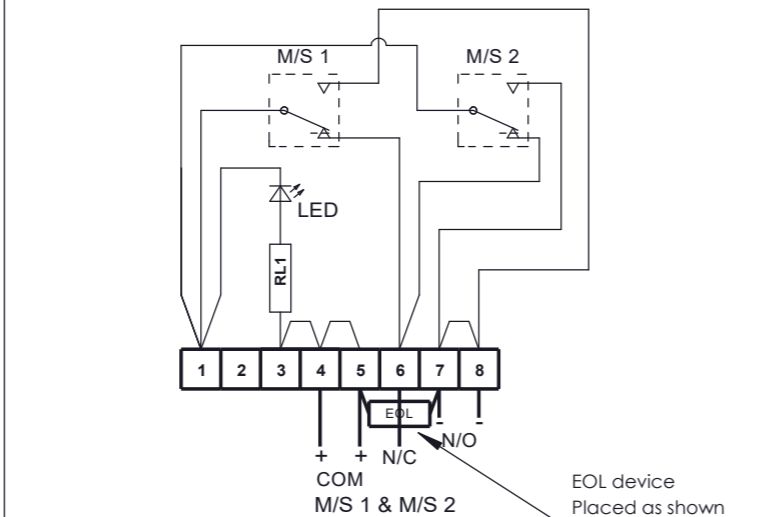
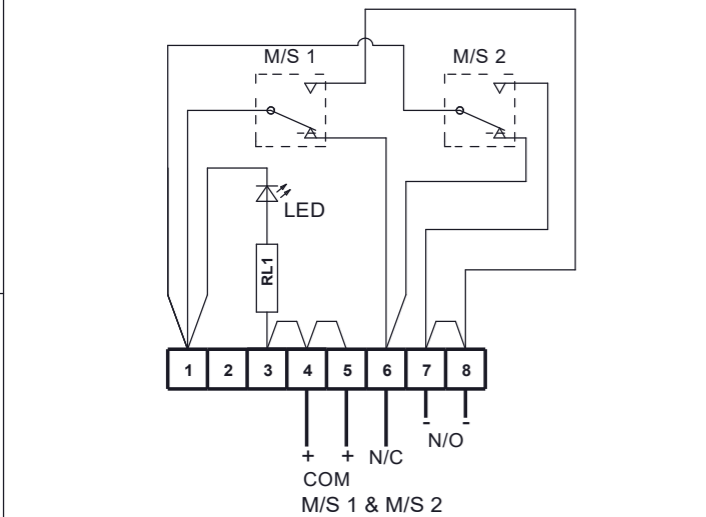
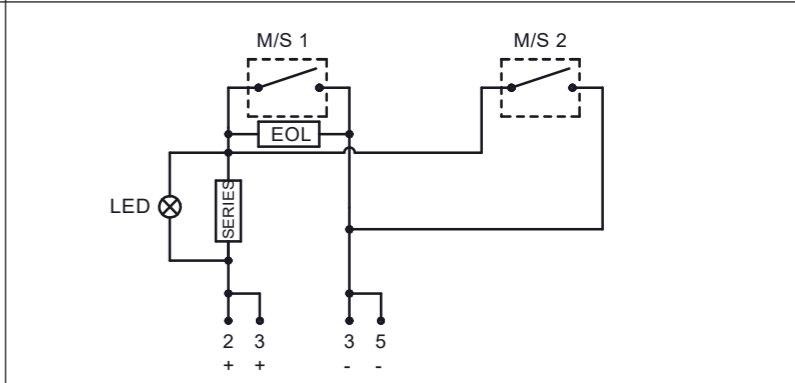
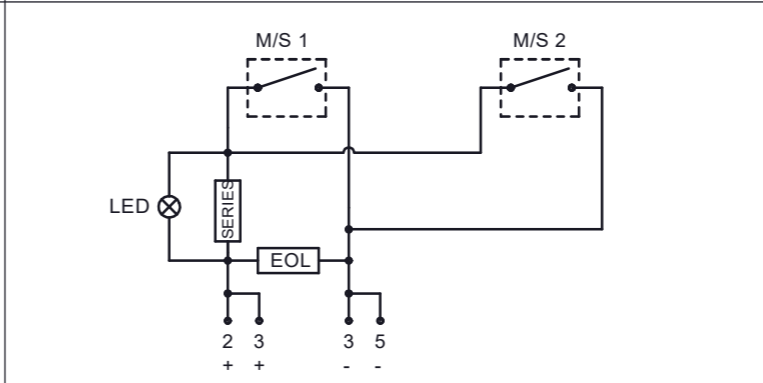
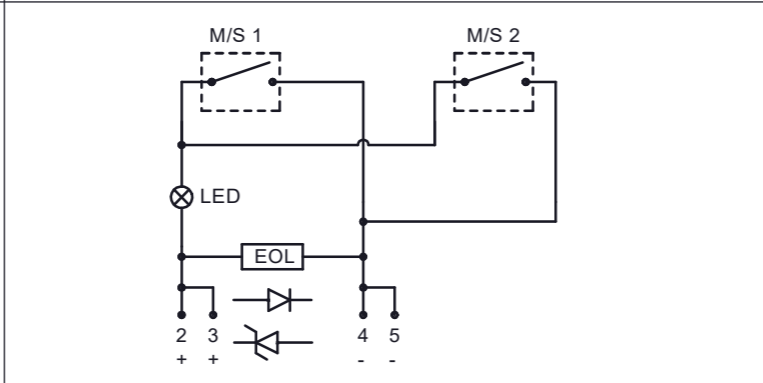
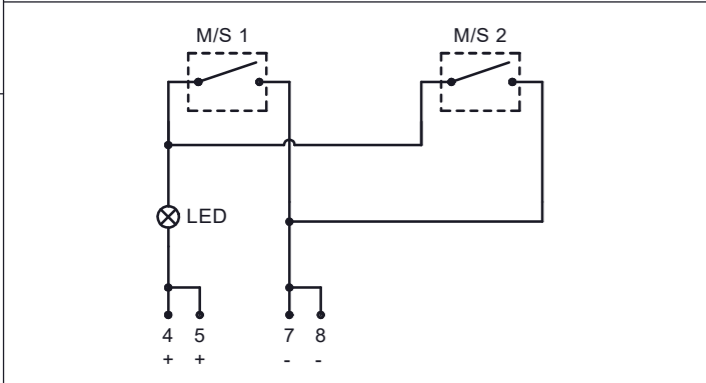

**Circuit shown in Unoperated condition**

**Unoperated condition (Glass Intact / Standby Condition)**  
 Terminals +(4,5) & -(7,8) open  
 Terminals +(4,5) & (6) closed

**Operated condition (Glass Broken / Button pushed in)**  
 Terminals +(4,5) & -(7,8) closed  
 Terminals +(4,5) & (6) open

**Circuit shown in Unoperated condition**

**Unoperated condition (Glass Intact / Standby Condition)**  
 Terminals +(4,5) & -(7,8) open  
 Terminals +(4,5) & (6) closed

**Operated condition (Glass Broken / Button pushed in)**  
 Terminals +(4,5) & -(7,8) closed  
 Terminals +(4,5) & (6) open

**Circuit shown in Unoperated condition**

**Unoperated condition (Glass Intact / Standby Condition)**  
 Terminals +(4,5) & -(7,8) open  
 Terminals +(4,5) & (6) closed

**Operated condition (Glass Broken / Button pushed in)**  
 Terminals +(4,5) & -(7,8) closed  
 Terminals +(4,5) & (6) open

**Circuit shown in Unoperated condition**

**Unoperated condition (Glass Intact / Standby Condition)**  
 Terminals +(4,5) & -(7,8) open  
 Terminals +(4,5) & (6) closed

**Operated condition (Glass Broken / Button pushed in)**  
 Terminals +(4,5) & -(7,8) closed  
 Terminals +(4,5) & (6) open

DRAWING TO BS8888:2000  
 GEOMETRIC TOLERANCES TO ISO1101:1983  
 LINEAR DIMENSIONAL TOLS  
 ANGULAR DIMENSIONAL TOLS

STANDARDS  
**GNExCP7 ; STExCP8 ; WP7 units with DIN Rail**

DRAWN	DATE
D.HOWGILL	05-03-2020
CHECKED	DATE
R.N.POTTS	05-03-2020
APPROVED	DATE
R.N.POTTS	05-03-2020

SURFACE FINISH	WEIGHT (Kg)
MATERIAL	
ALTERNATIVE MATERIAL	

THIS DRAWING AND ANY INFORMATION OR DESCRIPTIVE MATTER THEREIN IS COMMUNICATED IN CONFIDENCE AND IS THE COPYRIGHT PROPERTY OF EUROPEAN SAFETY SYSTEMS LTD. NEITHER THE WHOLE OR ANY EXTRACT MAY BE DISCLOSED, LOANED, COPIED OR USED FOR MANUFACTURING OR TENDERING PURPOSES WITHOUT THEIR WRITTEN CONSENT.

EUROPEAN SAFETY SYSTEMS LTD.  
 AS PER LATEST DATE OF ISSUE SHOWN ABOVE

EUROPEAN SAFETY SYSTEMS LTD  
 IMPRESS HOUSE  
 MANSELL ROAD  
 ACTON  
 LONDON W3 7QH  
 WWW.E2S.COM

ALL DIMENSIONS IN MM  
 IF IN DOUBT, ASK - DO NOT SCALE

TITLE **GNExCP7 ; STExCP8 ; WP7 CALL POINT WIRING / CIRCUIT OPERATION DIAGRAM**

SCALE	SHEET	DRAWING NUMBER
NTS	8 OF 8	<b>D202-06-211</b>



**SINGLE MICROSWITCH DEVICES**

**SHEET 1**

PRODUCTS:  
GNExCP7, STExCP8  
& WP7

Diagram	Sheet
Dual Switch Wiring Configurations	2,3,5,6,7,8
LED Indicator Wiring Configurations	4,5,6,8
Parallel Dual Switch Wiring Configurations	7,8

GNEXCP7-BG[s][t][l][e][m][d][v][o][x]-[u][e][s]  
 Switch Type [s] Terminals [t] Product Version [v] Product Option [o] LED Indicator [u] Series Module [s] EOL Module [e]

Module Device Codes		
	EOL	Series
Resistor	ExxxR	SxxxR
Diode	ED1	SD1
Zener Diode	ExxxZ	SxxxZ
LED	N/A	L or C

ISSUE	MOD No.	REASON - INITIAL - DATE
1	ACN0127	Addition of LED version ; Options clarified RNP 20-08-2023

SINGLE SWITCH	CONFIG. P1 -1	SINGLE SWITCH WITH SERIES DEVICE	CONFIG. P1-2	SINGLE SWITCH WITH EOL & SERIES DEVICES	CONFIG. P1-3	SINGLE SWITCH WITH EOL & ALT SERIES DEVICES	CONFIG. P1-4
---------------	---------------	----------------------------------	--------------	---	--------------	---	--------------

SWITCH TYPE [s] [S] TERMINALS [t] [P] PRODUCT OPTION [o] [1] LED INDICATOR [u] [N]	Single PCB Version Default NO LED	SWITCH TYPE [s] [S] TERMINALS [t] [P] PRODUCT OPTION [o] [1] LED INDICATOR [u] [N] EOL MODULE [e] [Exxxx]	Single PCB Version Default NO LED EOL Device	SWITCH TYPE [s] [S] TERMINALS [t] [P] PRODUCT OPTION [o] [1] LED INDICATOR [u] [N] MODULES [e][s] [Exxxx][Sxxxx]	Single PCB Version Default NO LED EOL + Series	SWITCH TYPE [s] [S] TERMINALS [t] [P] PRODUCT OPTION [o] [W] LED INDICATOR [u] [N] MODULE [e][s] [Exxxx][Sxxxx]	Single PCB Version Alt. EOL Pos'n. NO LED EOL + Series
---	---	---	---	--	---	---	---

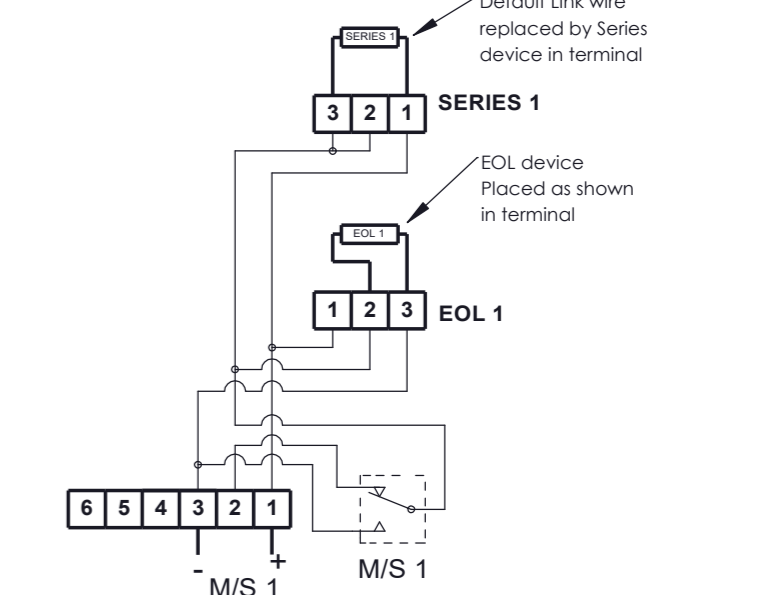
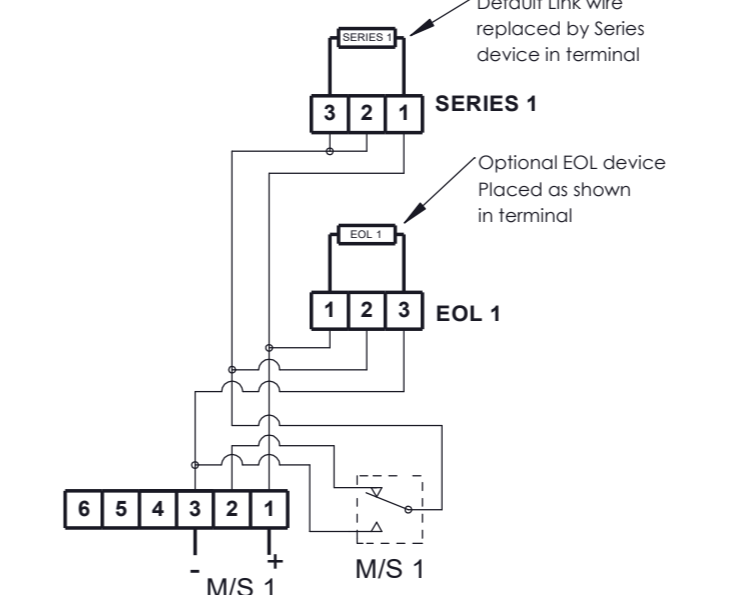
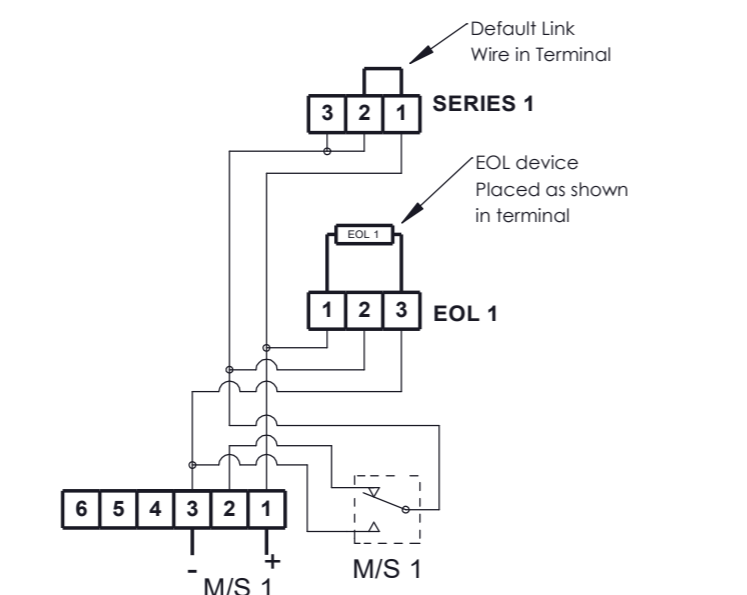
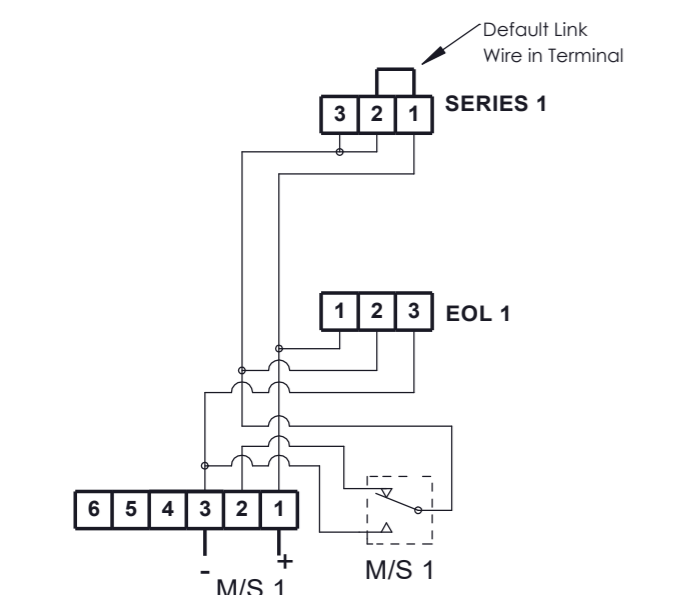
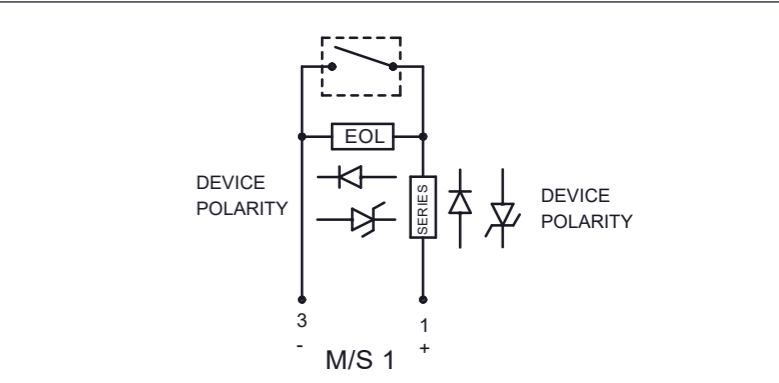
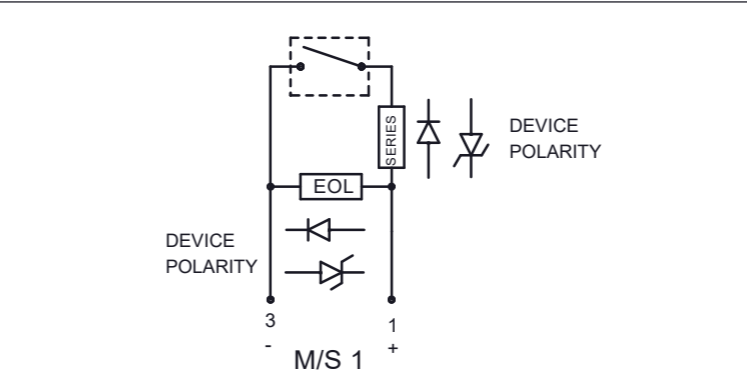
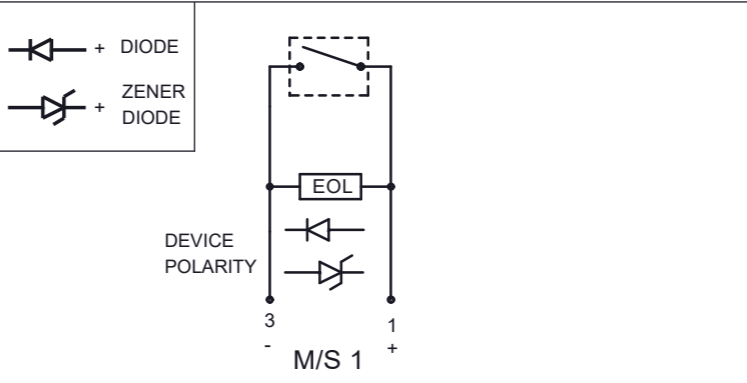
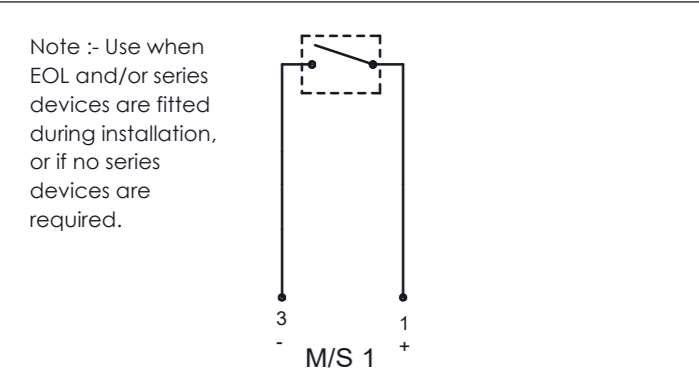

**Circuit as shown in Unoperated condition**

**Unoperated Condition (Glass Intact / Standby Condition)**  
 Terminals +(1) & -(3) M/S 1 open  
 Terminals +(1) & (2) M/S 1 closed

**Operated Condition (Glass Broken / Button pushes in)**  
 Terminals +(1) & (2) M/S 1 open  
 Terminals +(1) & -(3) M/S 1 closed

**Circuit as shown in Unoperated condition**

**Unoperated Condition (Glass Intact / Standby Condition)**  
 Terminals +(1) & -(3) M/S 1 open  
 Terminals +(1) & (2) M/S 1 closed

**Operated Condition (Glass Broken / Button pushes in)**  
 Terminals +(1) & (2) M/S 1 open  
 Terminals +(1) & -(3) M/S 1 closed

**Circuit as shown in Unoperated condition**

**Unoperated Condition (Glass Intact / Standby Condition)**  
 Terminals +(1) & -(3) M/S 1 open  
 Terminals +(1) & (2) M/S 1 closed

**Operated Condition (Glass Broken / Button pushes in)**  
 Terminals +(1) & (2) M/S 1 open  
 Terminals +(1) & -(3) M/S 1 closed

**Circuit as shown in Unoperated condition**

**Unoperated Condition (Glass Intact / Standby Condition)**  
 Terminals +(1) & -(3) M/S 1 open  
 Terminals +(1) & (2) M/S 1 closed

**Operated Condition (Glass Broken / Button pushes in)**  
 Terminals +(1) & (2) M/S 1 open  
 Terminals +(1) & -(3) M/S 1 closed

DRAWING TO BS8888:2000  
 GEOMETRIC TOLERANCES TO ISO1101:1983  
 LINEAR DIMENSIONAL TOLS  
 ANGULAR DIMENSIONAL TOLS

STANDARDS  
**GNExCP7 ; STExCP8 ; WP7 units with PCB**

DRAWN	DATE
R.N.POTTS	20-08-2023
CHECKED	DATE
B.ISARD	20-08-2023
APPROVED	DATE
R.N.POTTS	20-08-2023

SURFACE FINISH	WEIGHT (Kg)
MATERIAL	
ALTERNATIVE MATERIAL	

THIS DRAWING AND ANY INFORMATION OR DESCRIPTIVE MATTER THEREIN IS COMMUNICATED IN CONFIDENCE AND IS THE COPYRIGHT PROPERTY OF EUROPEAN SAFETY SYSTEMS LTD. NEITHER THE WHOLE OR ANY EXTRACT MAY BE DISCLOSED, LOANED, COPIED OR USED FOR MANUFACTURING OR TENDERING PURPOSES WITHOUT THEIR WRITTEN CONSENT.

© EUROPEAN SAFETY SYSTEMS LTD. AS PER LATEST DATE OF ISSUE SHOWN ABOVE

EUROPEAN SAFETY SYSTEMS LTD  
 IMPRESS HOUSE  
 MANSELL ROAD  
 ACTON  
 LONDON W3 7QH  
 WWW.E2S.COM

ALL DIMENSIONS IN MM IF IN DOUBT, ASK - DO NOT SCALE		
		<b>A3</b>
TITLE <b>GNExCP7 ; STExCP8 ; WP7 CALL POINT WIRING / CIRCUIT OPERATION DIAGRAM</b>		
SCALE	SHEET	DRAWING NUMBER
NTS	1 OF 8	<b>D202-06-212</b>

**DUAL MICROSWITCH DEVICES**

**SHEET 2**

GNEXCP7-BG[s][t][l][e][m][d][v][o][x]-[u][e][s] Series Module [s]  
 Switch Type [s] Terminals [t] Product Version [v] Product Option [o] LED Indicator [u] EOL Module [e]

Module Device Codes		
	EOL	Series
Resistor	ExxxR	SxxxR
Diode	ED1	SD1
Zener Diode	ExxxZ	SxxxZ
LED	N/A	L or C

ISSUE	MOD No.	REASON - INITIAL - DATE
1	ACN0127	INTRODUCTION RNP 20-08-2023

Notes:  
 1. Other configurations of dual switch units are possible. Contact E2S sales to discuss options.

DUAL SWITCH	CONFIG. P2-1	DUAL SWITCH WITH EOL & SERIES DEVICES	CONFIG. P2-2	DUAL SWITCH WITH EOL & ALT. SERIES DEVICES	CONFIG. P2-3
-------------	--------------	---------------------------------------	--------------	--	--------------

SWITCH TYPE [s] [D] TERMINALS [t] [P] PRODUCT OPTION [o] [1] LED INDICATOR [u] [N]	Dual PCB Version Default NO LED	SWITCH TYPE [s] [D] TERMINALS [t] [P] PRODUCT OPTION [o] [1] LED INDICATOR [u] [N] MODULES [e][s] [Exxxx][Sxxxx]	Dual PCB Version Default No LED EOL + Series	SWITCH TYPE [s] [D] TERMINALS [t] [P] PRODUCT OPTION [o] [W] LED INDICATOR [u] [N] MODULES [e][s] [Exxxx][Sxxxx]	Dual PCB Version Alt. EOL Pos'n. No LED EOL + Series
---	---------------------------------------	--	---	--	---

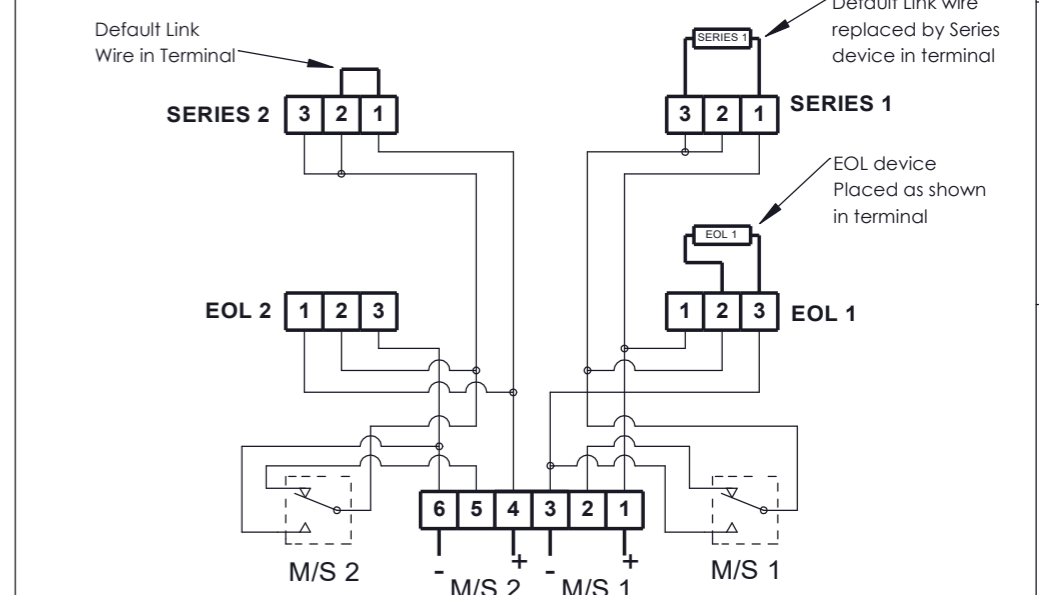
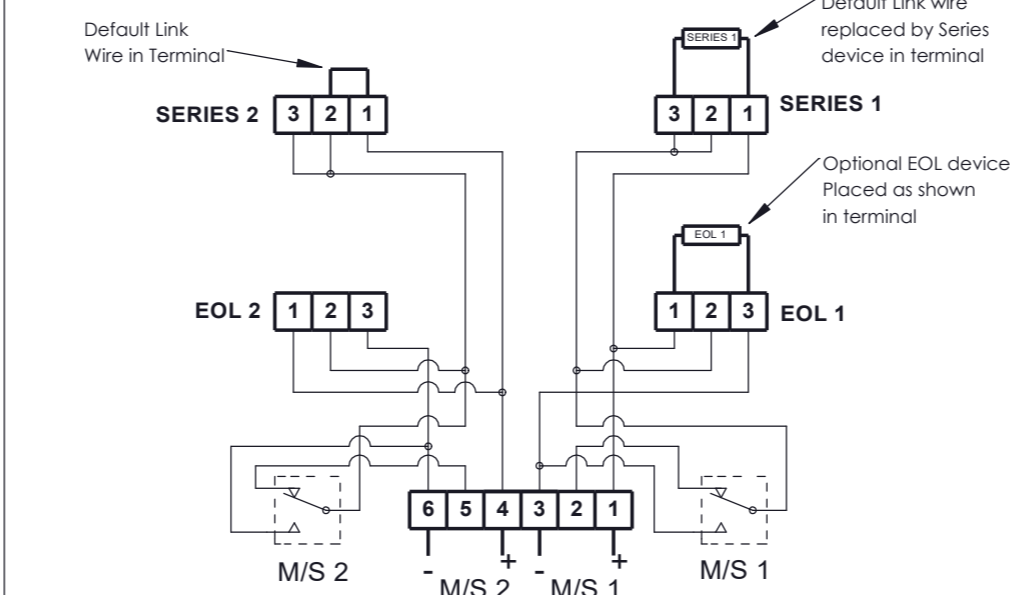
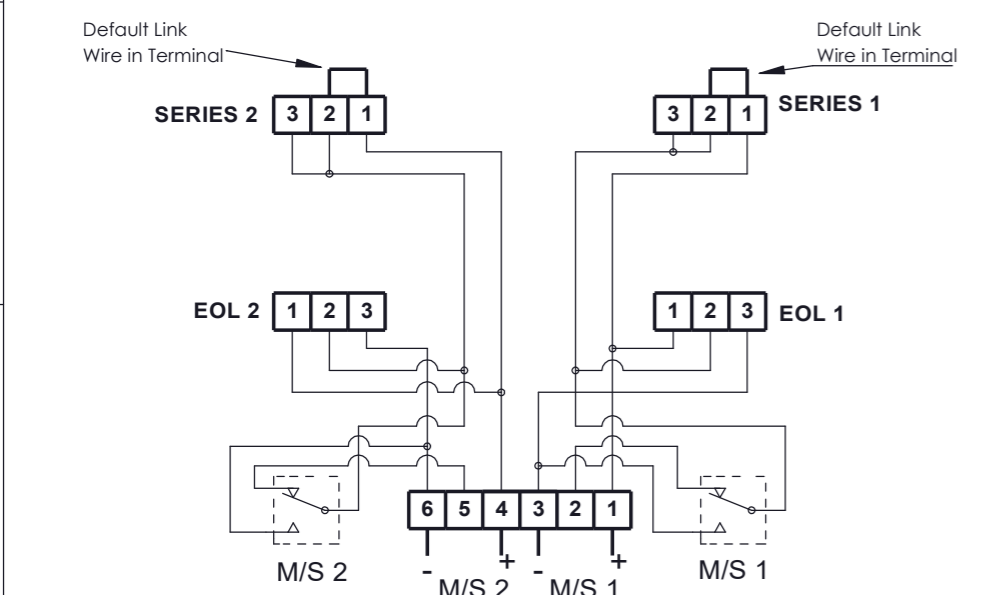
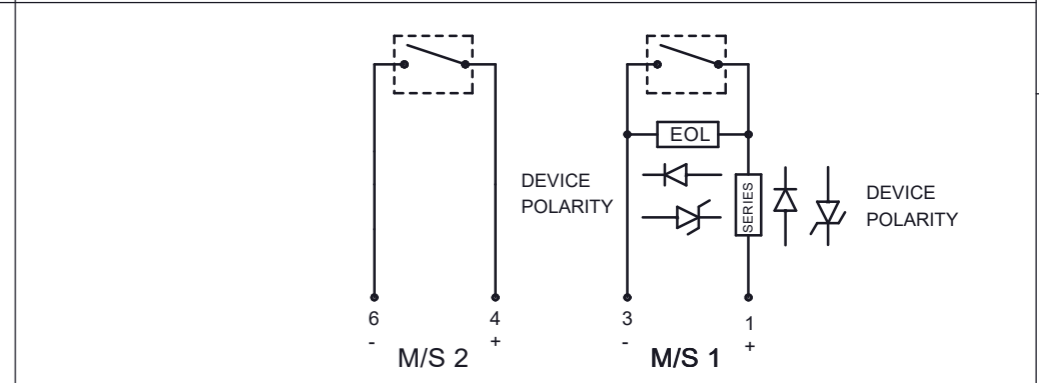
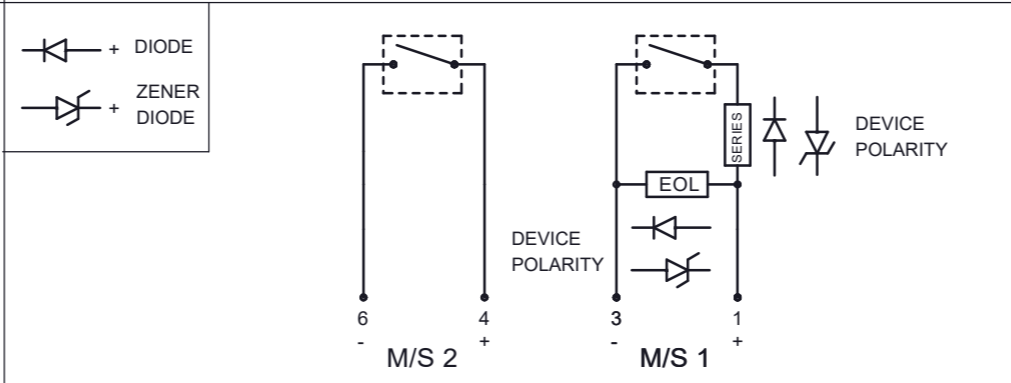
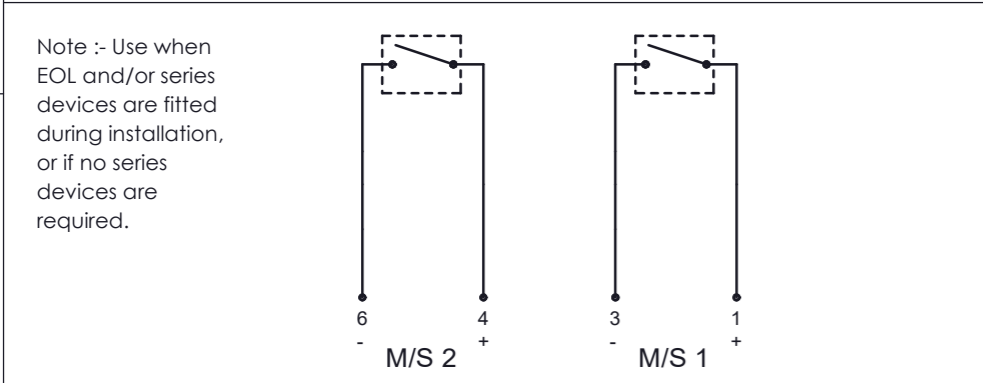

**Circuit as shown in Unoperated condition**

**Unoperated Condition (Glass Intact / Standby Condition)**  
 Terminals +(1) & -(3) M/S 1 and +(4) & -(6) M/S 2 open  
 Terminals +(1) & (2) M/S 1 and +(4) & (5) M/S 2 closed

**Operated Condition (Glass Broken / Button pushes in)**  
 Terminals +(1) & (2) M/S 1 and +(4) & (5) M/S 2 open  
 Terminals +(1) & -(3) M/S 1 and +(4) & -(6) M/S 2 closed

**Circuit as shown in Unoperated condition**

**Unoperated Condition (Glass Intact / Standby Condition)**  
 Terminals +(1) & -(3) M/S 1 and +(4) & -(6) M/S 2 open  
 Terminals +(1) & (2) M/S 1 and +(4) & (5) M/S 2 closed

**Operated Condition (Glass Broken / Button pushes in)**  
 Terminals +(1) & (2) M/S 1 and +(4) & (5) M/S 2 open  
 Terminals +(1) & -(3) M/S 1 and +(4) & -(6) M/S 2 closed

**Circuit as shown in Unoperated condition**

**Unoperated Condition (Glass Intact / Standby Condition)**  
 Terminals +(1) & -(3) M/S 1 and +(4) & -(6) M/S 2 open  
 Terminals +(1) & (2) M/S 1 and +(4) & (5) M/S 2 closed

**Operated Condition (Glass Broken / Button pushes in)**  
 Terminals +(1) & (2) M/S 1 and +(4) & (5) M/S 2 open  
 Terminals +(1) & -(3) M/S 1 and +(4) & -(6) M/S 2 closed

DRAWING TO BS8888:2000 GEOMETRIC TOLERANCES TO ISO1101:1983 LINEAR DIMENSIONAL TOLS ANGULAR DIMENSIONAL TOLS	DRAWN	DATE	SURFACE FINISH	WEIGHT (Kg)
	R.N.POTTS	20-08-2023		
	CHECKED	DATE		
STANDARDS GNEXCP7 ; STExCP8 ; WP7 units with PCB	B.ISARD	20-08-2023	MATERIAL	
	APPROVED	DATE	ALTERNATIVE MATERIAL	
	R.N.POTTS	20-08-2023		

THIS DRAWING AND ANY INFORMATION OR DESCRIPTIVE MATTER THEREIN IS COMMUNICATED IN CONFIDENCE AND IS THE COPYRIGHT PROPERTY OF EUROPEAN SAFETY SYSTEMS LTD. NEITHER THE WHOLE OR ANY EXTRACT MAY BE DISCLOSED, LOANED, COPIED OR USED FOR MANUFACTURING OR TENDERING PURPOSES WITHOUT THEIR WRITTEN CONSENT.

EUROPEAN SAFETY SYSTEMS LTD.  
 AS PER LATEST DATE OF ISSUE SHOWN ABOVE

EUROPEAN SAFETY SYSTEMS LTD  
 IMPRESS HOUSE  
 MANSELL ROAD  
 ACTON  
 LONDON W3 7QH  
 WWW.E2S.COM

ALL DIMENSIONS IN MM IF IN DOUBT, ASK - DO NOT SCALE				<b>A3</b>
TITLE <b>GNEXCP7 ; STExCP8 ; WP7 CALL POINT WIRING / CIRCUIT OPERATION DIAGRAM</b>				
SCALE	SHEET	DRAWING NUMBER		
NTS	2 OF 8	<b>D202-06-212</b>		

**DUAL MICROSWITCH DEVICES DUPLICATED**

**SHEET 3**

GNEXCP7-BG[s][t][l][e][m][d][v][o][x]-[u][e][s] LED Indicator [u]  
 Switch Type [s] Product Version [v] Product Option [o] EOL Module [e] Series Module [s]

Module Device Codes		
	EOL	Series
Resistor	ExxxR	SxxxR
Diode	ED1	SD1
Zener Diode	ExxxZ	SxxxZ
LED	N/A	L or C

ISSUE	MOD No.	REASON - INITIAL - DATE
1	ACN0127	INTRODUCTION RNP 20-08-2023

Notes:  
 1. Other configurations of dual switch units are possible. Contact E2S sales to discuss options.

**DUAL SWITCH WITH EOL & SERIES DEVICES DUPLICATED**

**CONFIG. P3-1**

**DUAL SWITCH WITH EOL & ALT. SERIES DEVICES DUPLICATED**

**CONFIG. P3-2**

SWITCH TYPE [s] [D] Dual  
 TERMINALS [t] [P] PCB Version  
 PRODUCT OPTION [o] [2] Duplicate EOL/Series  
 LED INDICATOR [u] [N] No LED  
 MODULES [e][s] [Exxxx][Sxxxx] EOL + Series

SWITCH TYPE [s] [D] Dual  
 TERMINALS [t] [P] PCB Version  
 PRODUCT OPTION [o] [Y] Alt. EOL Pos'n, duplicated  
 LED INDICATOR [u] [N] No LED  
 MODULES [e][s] [Exxxx][Sxxxx] EOL + Series

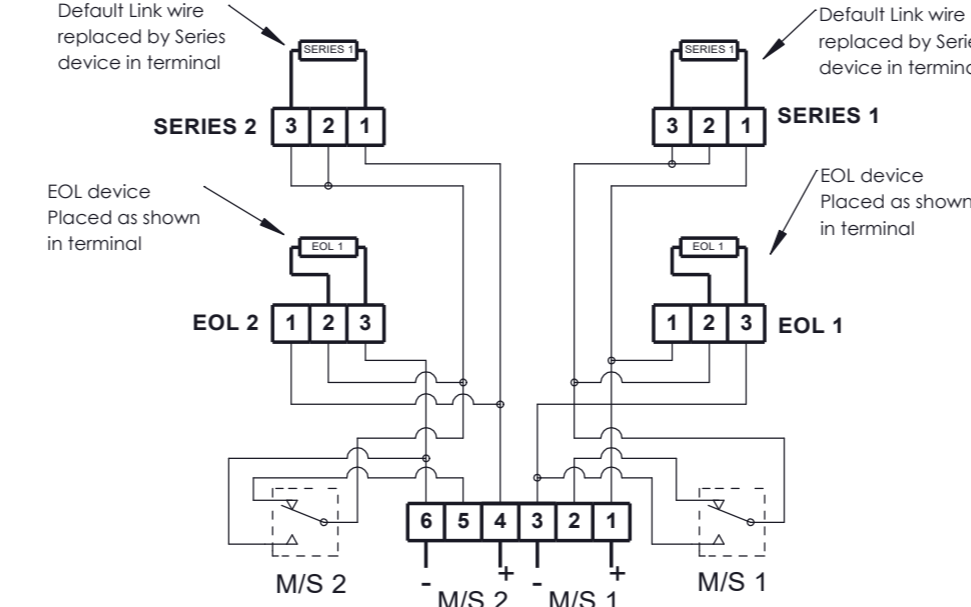
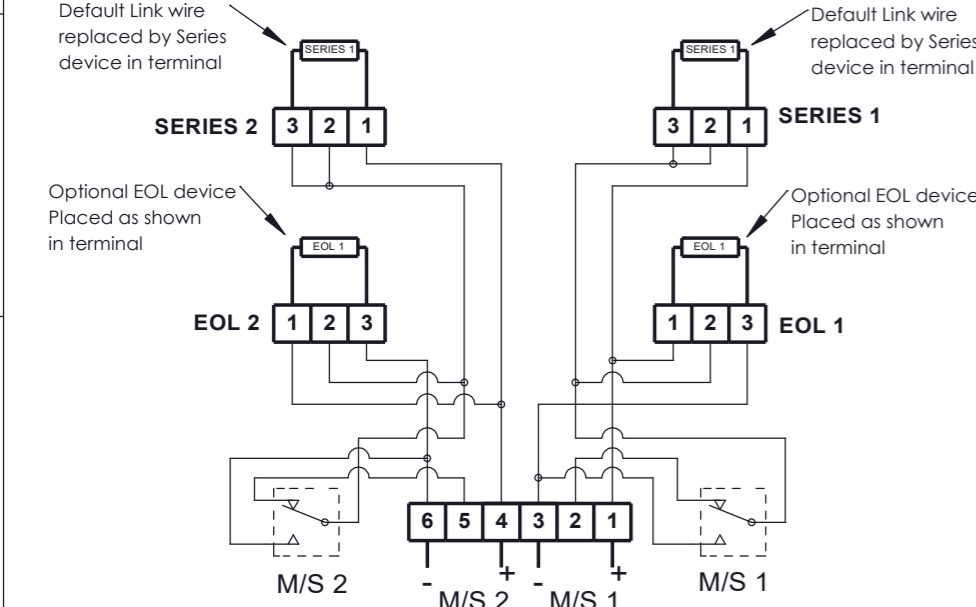
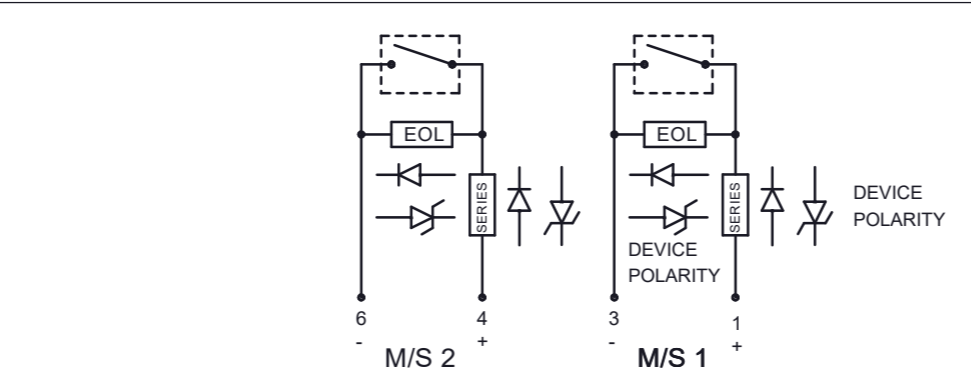
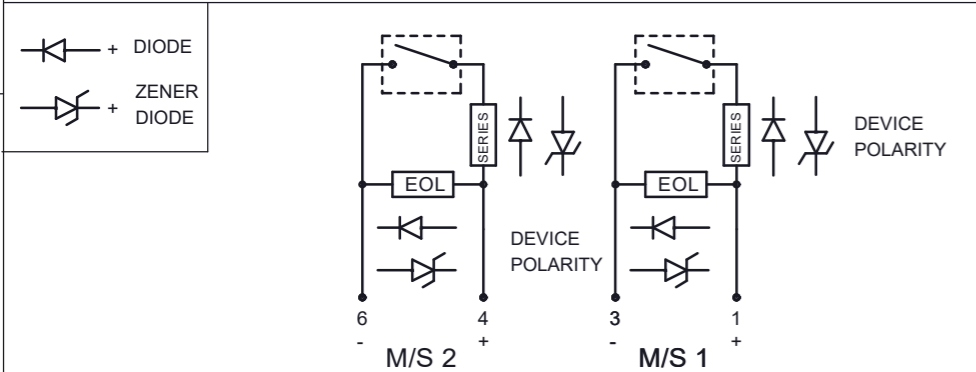

**Circuit as shown in Unoperated condition**

**Unoperated Condition (Glass Intact / Standby Condition)**  
 Terminals +(1) & -(3) M/S 1 and +(4) & -(6) M/S 2 open  
 Terminals +(1) & (2) M/S 1 and +(4) & (5) M/S 2 closed

**Operated Condition (Glass Broken / Button pushes in)**  
 Terminals +(1) & (2) M/S 1 and +(4) & (5) M/S 2 open  
 Terminals +(1) & -(3) M/S 1 and +(4) & -(6) M/S 2 closed

**Circuit as shown in Unoperated condition**

**Unoperated Condition (Glass Intact / Standby Condition)**  
 Terminals +(1) & -(3) M/S 1 and +(4) & -(6) M/S 2 open  
 Terminals +(1) & (2) M/S 1 and +(4) & (5) M/S 2 closed

**Operated Condition (Glass Broken / Button pushes in)**  
 Terminals +(1) & (2) M/S 1 and +(4) & (5) M/S 2 open  
 Terminals +(1) & -(3) M/S 1 and +(4) & -(6) M/S 2 closed

DRAWING TO BS8888:2000  
 GEOMETRIC TOLERANCES TO ISO1101:1983  
 LINEAR DIMENSIONAL TOLS  
 ANGULAR DIMENSIONAL TOLS

STANDARDS  
**GNExCP7 ; STExCP8 ; WP7 units with PCB**

DRAWN	R.N.POTTS	DATE	20-08-2023
CHECKED	B.ISARD	DATE	20-08-2023
APPROVED	R.N.POTTS	DATE	20-08-2023

SURFACE FINISH

WEIGHT (Kg)

MATERIAL

ALTERNATIVE MATERIAL

THIS DRAWING AND ANY INFORMATION OR DESCRIPTIVE MATTER THEREIN IS COMMUNICATED IN CONFIDENCE AND IS THE COPYRIGHT PROPERTY OF EUROPEAN SAFETY SYSTEMS LTD. NEITHER THE WHOLE OR ANY EXTRACT MAY BE DISCLOSED, LOANED, COPIED OR USED FOR MANUFACTURING OR TENDERING PURPOSES WITHOUT THEIR WRITTEN CONSENT.

© EUROPEAN SAFETY SYSTEMS LTD. AS PER LATEST DATE OF ISSUE SHOWN ABOVE

**e2S** warning signals  
 EUROPEAN SAFETY SYSTEMS LTD  
 IMPRESS HOUSE  
 MANSELL ROAD  
 ACTON  
 LONDON W3 7QH  
 WWW.E2S.COM

ALL DIMENSIONS IN MM  
 IF IN DOUBT, ASK - DO NOT SCALE

**A3**

TITLE **GNExCP7 ; STExCP8 ; WP7 CALL POINT WIRING / CIRCUIT OPERATION DIAGRAM**

SCALE	SHEET	DRAWING NUMBER
NTS	3 OF 8	<b>D202-06-212</b>

**SINGLE MICROSWITCH LED DEVICES**

**SHEET 4**

Notes:  
1. Units have the option to remove the LED current-limiting resistor RL1 option 'L' using LED option 'C'. In all other cases shown RL1 is included.



Module Device Codes		
	EOL	Series
Resistor	ExxxR	SxxxR
Diode	ED1	SD1
Zener Diode	ExxxZ	SxxxZ
LED	N/A	L or C

ISSUE	MOD No.	REASON - INITIAL - DATE
1	ACN0127	Addition of LED version ; Options clarified RNP 20-08-2023

SINGLE SWITCH	CONFIG. P4 -1	SINGLE SWITCH WITH SERIES DEVICES	CONFIG. P4-2	SINGLE SWITCH WITH EOL & SERIES DEVICES	CONFIG. P4-3	SINGLE SWITCH WITH EOL & ALT SERIES DEVICES	CONFIG. P4-4
SWITCH TYPE [s] [S] TERMINALS [t] [P] PRODUCT OPTION [o] [1] LED INDICATOR [u] [L]	Single PCB Version Default LED with RL1	SWITCH TYPE [s] [S] TERMINALS [t] [P] PRODUCT OPTION [o] [1] LED INDICATOR [u] [L] EOL MODULE [e] [Exxxx]	Single PCB Version Default LED with RL1 EOL Device	SWITCH TYPE [s] [S] TERMINALS [t] [P] PRODUCT OPTION [o] [1] LED INDICATOR [u] [L] MODULES [e][s] [Exxxx][Sxxxx]	Single PCB Version Default LED with RL1 EOL + Series	SWITCH TYPE [s] [S] TERMINALS [t] [P] PRODUCT OPTION [o] [W] LED INDICATOR [u] [L] MODULE [e][s] [Exxxx][Sxxxx]	Single PCB Version Alt. EOL Pos'n. LED with RL1 EOL + Series

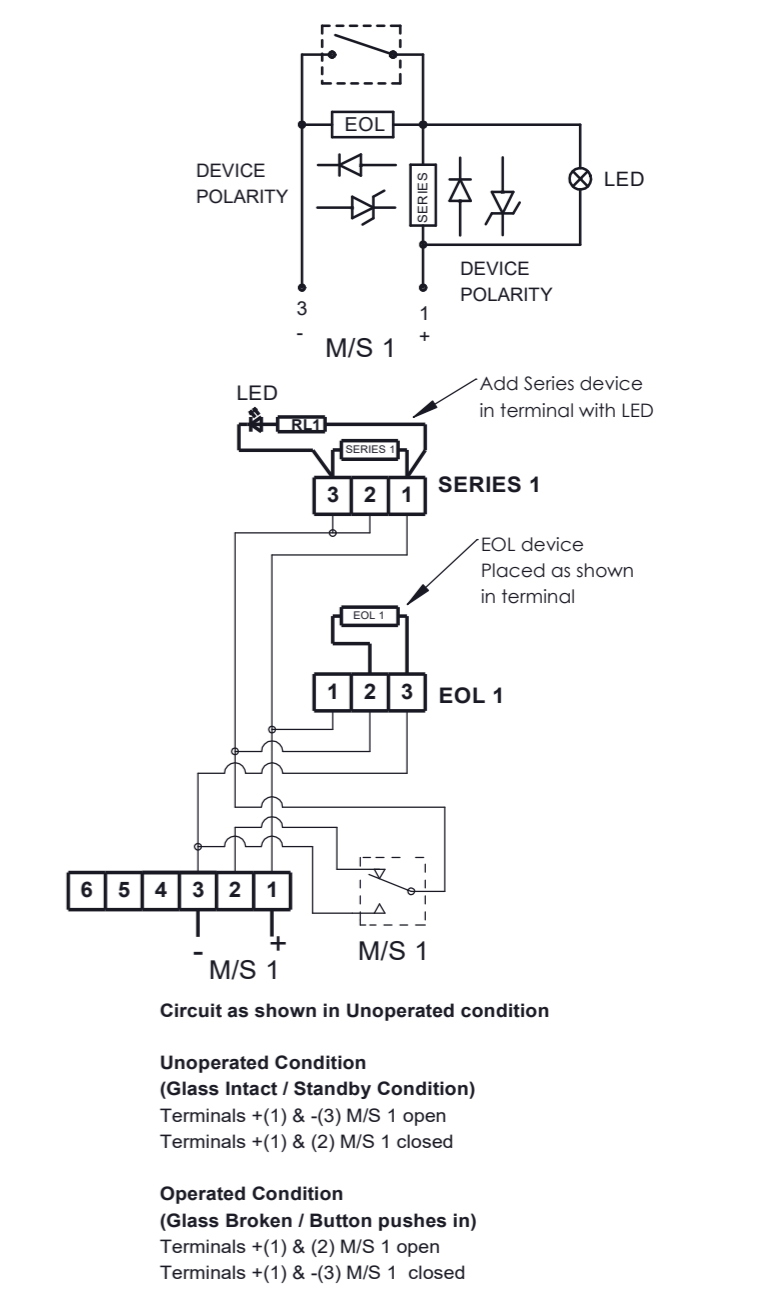
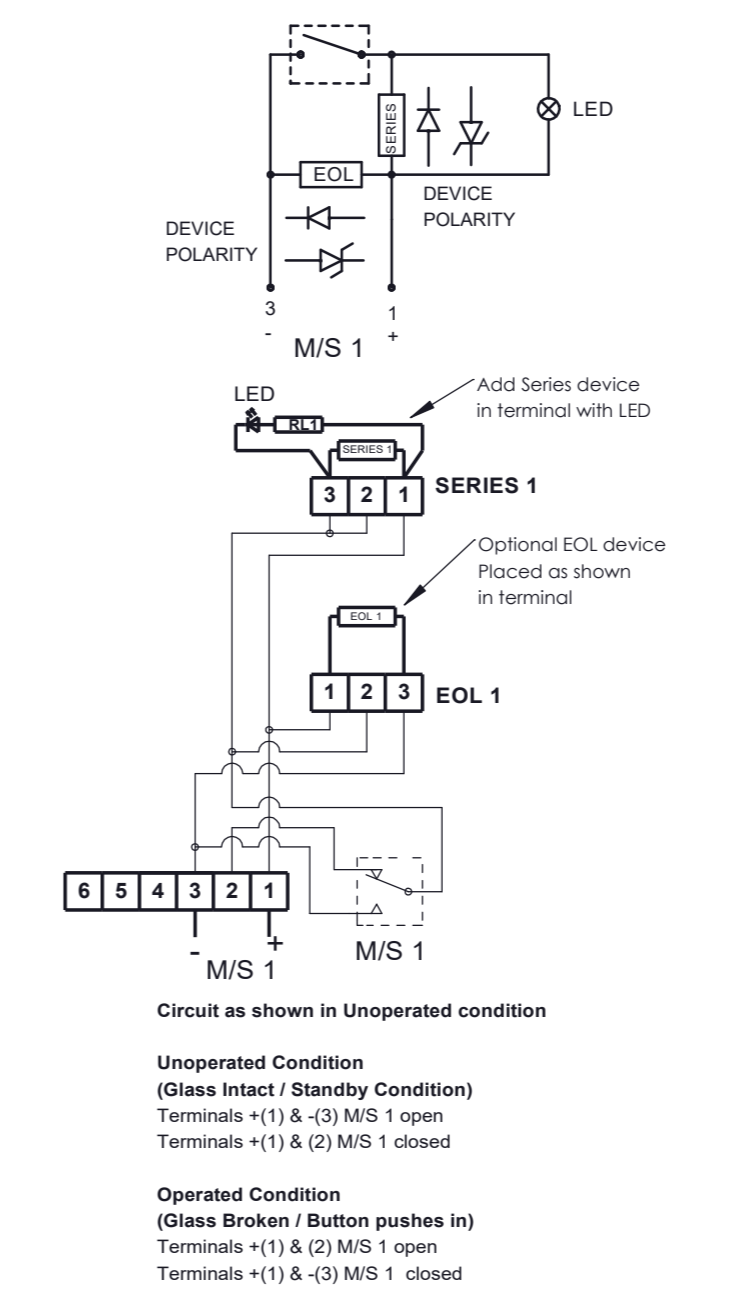
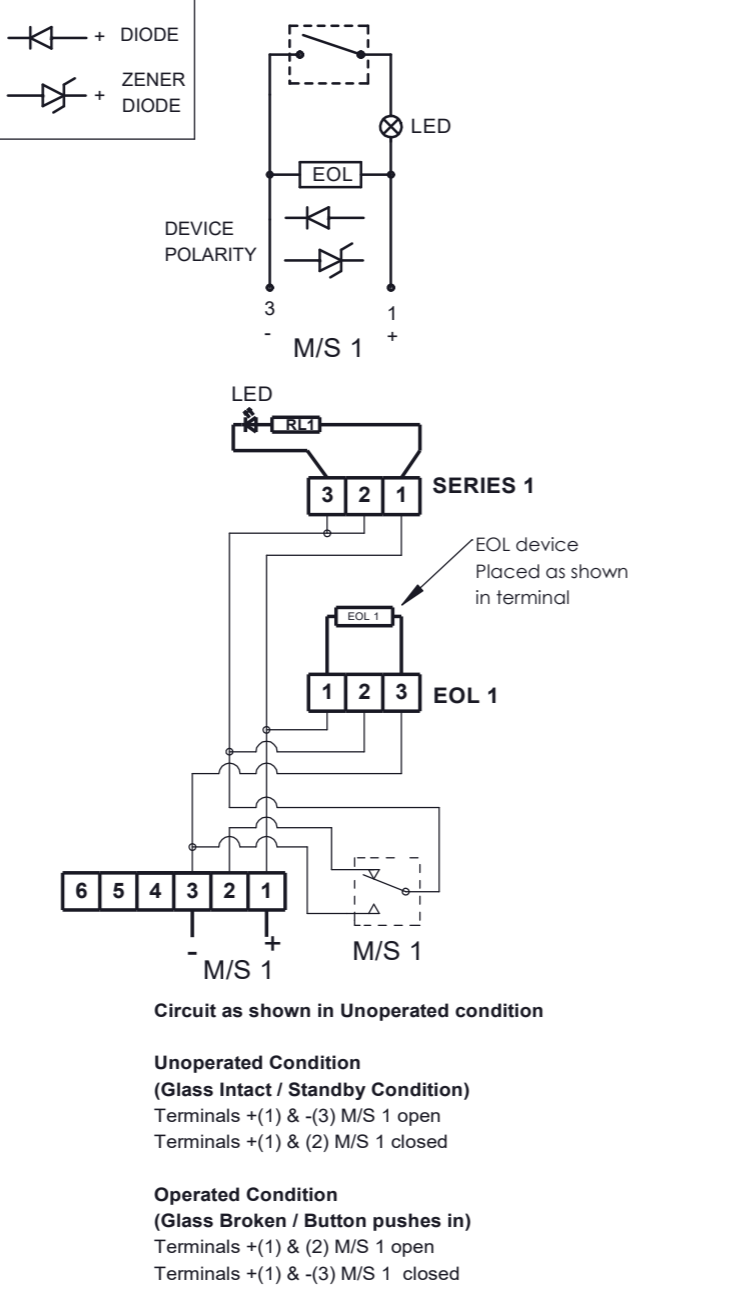
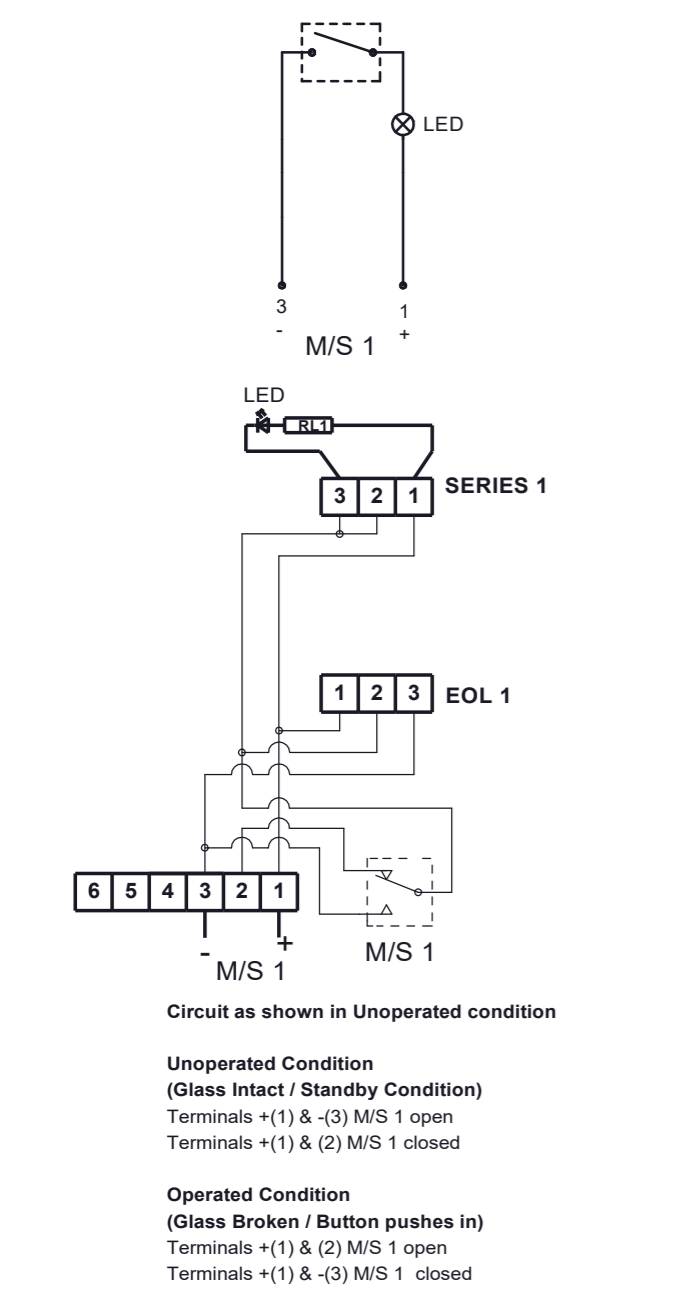

DRAWING TO BS8888:2000  
GEOMETRIC TOLERANCES TO ISO1101:1983  
LINEAR DIMENSIONAL TOLS  
ANGULAR DIMENSIONAL TOLS

STANDARDS  
**GNE<sub>x</sub>CP7 ; STExCP8 ; WP7 units with PCB**

DRAWN	R.N.POTTS	DATE	20-08-2023
CHECKED	B.ISARD	DATE	20-08-2023
APPROVED	R.N.POTTS	DATE	20-08-2023

SURFACE FINISH	WEIGHT (Kg)
MATERIAL	
ALTERNATIVE MATERIAL	

THIS DRAWING AND ANY INFORMATION OR DESCRIPTIVE MATTER THEREIN IS COMMUNICATED IN CONFIDENCE AND IS THE COPYRIGHT PROPERTY OF EUROPEAN SAFETY SYSTEMS LTD. NEITHER THE WHOLE OR ANY EXTRACT MAY BE DISCLOSED, LOANED, COPIED OR USED FOR MANUFACTURING OR TENDERING PURPOSES WITHOUT THEIR WRITTEN CONSENT.

EUROPEAN SAFETY SYSTEMS LTD.  
AS PER LATEST DATE OF ISSUE SHOWN ABOVE

EUROPEAN SAFETY SYSTEMS LTD  
IMPRESS HOUSE  
MANSELL ROAD  
ACTON  
LONDON W3 7QH  
WWW.E2S.COM

ALL DIMENSIONS IN MM IF IN DOUBT, ASK - DO NOT SCALE				<b>A3</b>
TITLE <b>GNE<sub>x</sub>CP7 ; STExCP8 ; WP7 CALL POINT WIRING / CIRCUIT OPERATION DIAGRAM</b>				
SCALE	SHEET	DRAWING NUMBER		
NTS	4 OF 8	<b>D202-06-212</b>		

# DUAL MICROSWITCH LED DEVICES

# SHEET 5

GNEXCP7-BG[s][t][l][e][m][d][v][o][x]-[u][e][s] LED Indicator [u]  
 Switch Type [s] Product Version [v] Product Option [o] EOL Module [e]  
 Terminals [t] Series

Module Device Codes		
	EOL	Series
Resistor	ExxxR	SxxxR
Diode	ED1	SD1
Zener Diode	ExxxZ	SxxxZ
LED	N/A	L or C

ISSUE	MOD No.	REASON - INITIAL - DATE
1	ACN0127	INTRODUCTION RNP 20-08-2023

Notes:  
 1. Units have the option to remove the LED current-limiting resistor RL1 option 'L' using LED option 'C'. In all other cases shown RL1 is included.

DUAL SWITCH WITH LED	CONFIG. P5-1	DUAL SWITCH WITH LED, EOL & SERIES DEVICES	CONFIG. P5-2	DUAL SWITCH WITH LED, EOL & ALT. SERIES DEVICES	CONFIG. P5-3
----------------------	--------------	--	--------------	---	--------------

SWITCH TYPE [s] [D] TERMINALS [t] [P] PRODUCT OPTION [o] [1] LED INDICATOR [u] [L]	Dual PCB Version Default LED with RL1	SWITCH TYPE [s] [D] TERMINALS [t] [P] PRODUCT OPTION [o] [1] LED INDICATOR [u] [L] MODULES [e][s] [Exxxx][Sxxxx]	Dual PCB Version Default LED with RL1 EOL + Series	SWITCH TYPE [s] [D] TERMINALS [t] [P] PRODUCT OPTION [o] [W] LED INDICATOR [u] [L] MODULES [e][s] [Exxxx][Sxxxx]	Dual PCB Version Alt. EOL Pos'n. LED with RL1 EOL + Series
---	--	--	--	--	--

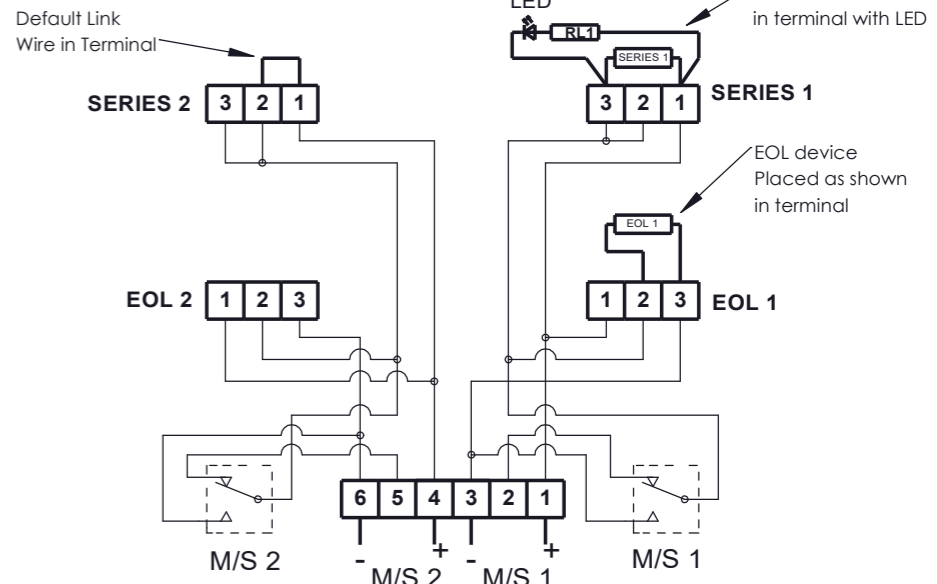
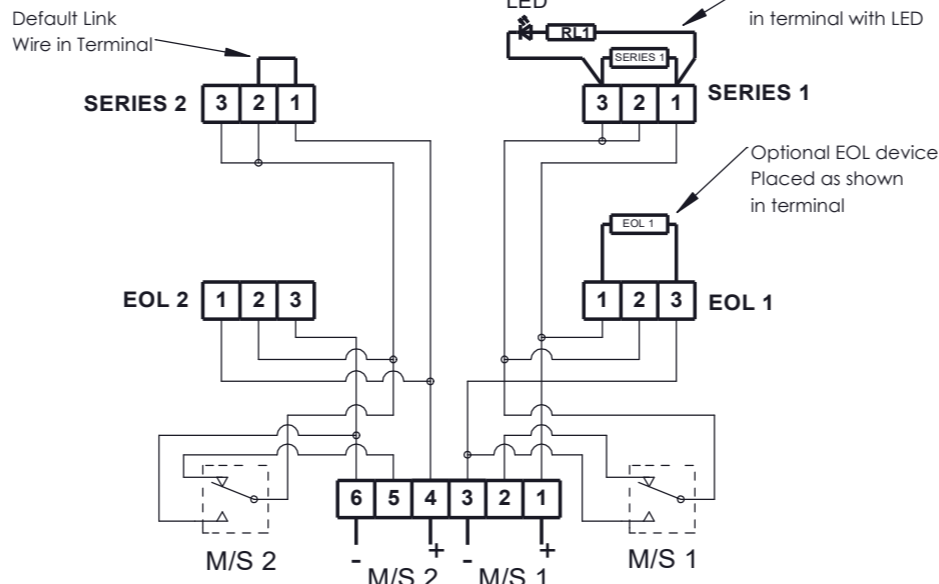
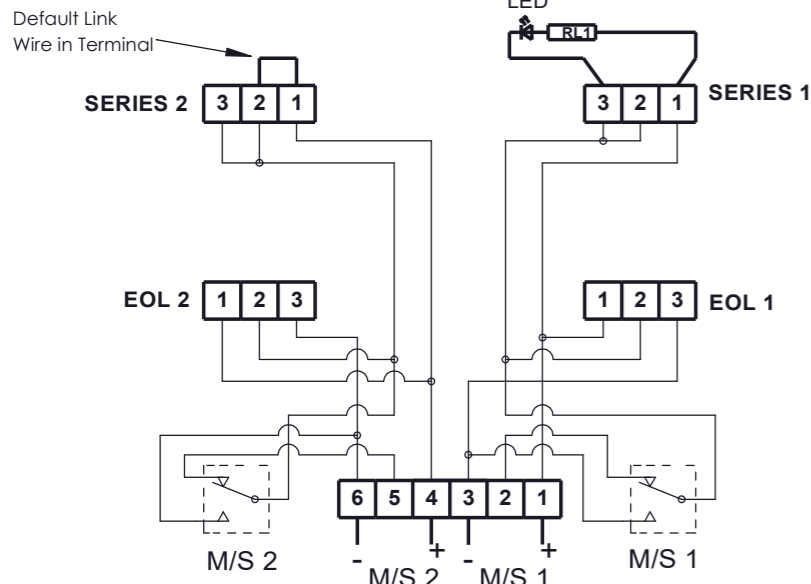
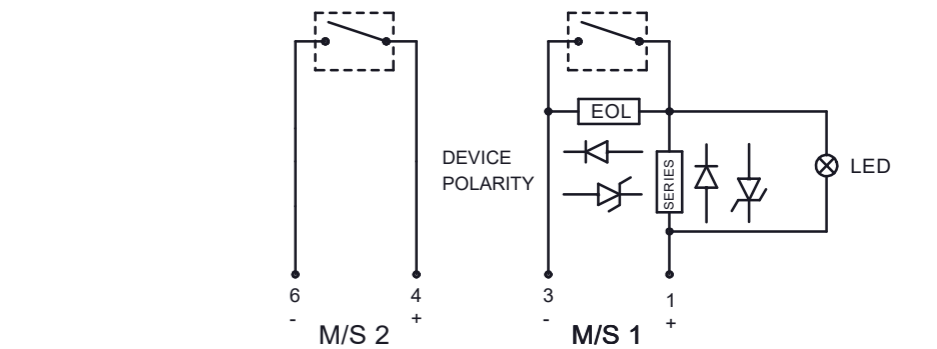
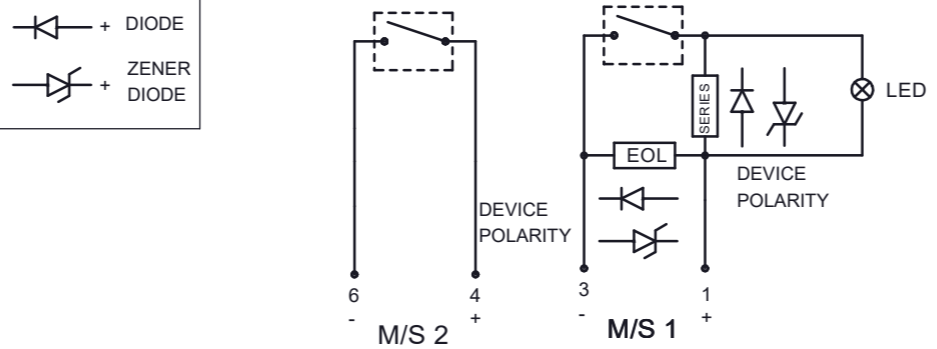
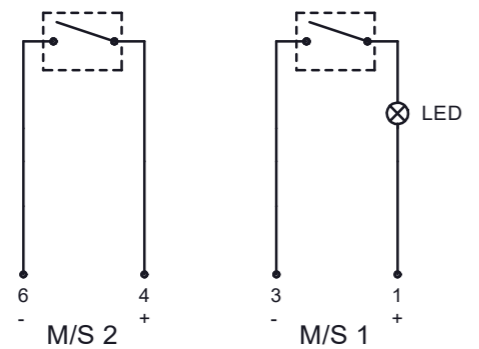

**Circuit as shown in Unoperated condition**

**Unoperated Condition (Glass Intact / Standby Condition)**  
 Terminals +(1) & -(3) M/S 1 and +(4) & -(6) M/S 2 open  
 Terminals +(1) & (2) M/S 1 and +(4) & (5) M/S 2 closed

**Operated Condition (Glass Broken / Button pushes in)**  
 Terminals +(1) & (2) M/S 1 and +(4) & (5) M/S 2 open  
 Terminals +(1) & -(3) M/S 1 and +(4) & -(6) M/S 2 closed

**Circuit as shown in Unoperated condition**

**Unoperated Condition (Glass Intact / Standby Condition)**  
 Terminals +(1) & -(3) M/S 1 and +(4) & -(6) M/S 2 open  
 Terminals +(1) & (2) M/S 1 and +(4) & (5) M/S 2 closed

**Operated Condition (Glass Broken / Button pushes in)**  
 Terminals +(1) & (2) M/S 1 and +(4) & (5) M/S 2 open  
 Terminals +(1) & -(3) M/S 1 and +(4) & -(6) M/S 2 closed

**Circuit as shown in Unoperated condition**

**Unoperated Condition (Glass Intact / Standby Condition)**  
 Terminals +(1) & -(3) M/S 1 and +(4) & -(6) M/S 2 open  
 Terminals +(1) & (2) M/S 1 and +(4) & (5) M/S 2 closed

**Operated Condition (Glass Broken / Button pushes in)**  
 Terminals +(1) & (2) M/S 1 and +(4) & (5) M/S 2 open  
 Terminals +(1) & -(3) M/S 1 and +(4) & -(6) M/S 2 closed

DRAWING TO BS8888:2000  
 GEOMETRIC TOLERANCES TO ISO1101:1983  
 LINEAR DIMENSIONAL TOLS  
 ANGULAR DIMENSIONAL TOLS

STANDARDS  
**GNEXCP7 ; STEXCP8 ; WP7 units with PCB**

DRAWN	R.N.POTTS	DATE	20-08-2023
CHECKED	B.ISARD	DATE	20-08-2023
APPROVED	R.N.POTTS	DATE	20-08-2023

SURFACE FINISH	WEIGHT (Kg)
MATERIAL	
ALTERNATIVE MATERIAL	

THIS DRAWING AND ANY INFORMATION OR DESCRIPTIVE MATTER THEREIN IS COMMUNICATED IN CONFIDENCE AND IS THE COPYRIGHT PROPERTY OF EUROPEAN SAFETY SYSTEMS LTD. NEITHER THE WHOLE OR ANY EXTRACT MAY BE DISCLOSED, LOANED, COPIED OR USED FOR MANUFACTURING OR TENDERING PURPOSES WITHOUT THEIR WRITTEN CONSENT.

© EUROPEAN SAFETY SYSTEMS LTD. AS PER LATEST DATE OF ISSUE SHOWN ABOVE

EUROPEAN SAFETY SYSTEMS LTD  
 IMPRESS HOUSE  
 MANSELL ROAD  
 ACTON  
 LONDON W3 7QH  
 WWW.E2S.COM

ALL DIMENSIONS IN MM IF IN DOUBT, ASK - DO NOT SCALE				<b>A3</b>
TITLE <b>GNEXCP7 ; STEXCP8 ; WP7 CALL POINT WIRING / CIRCUIT OPERATION DIAGRAM</b>				
SCALE	SHEET	DRAWING NUMBER		
NTS	5 OF 8	<b>D202-06-212</b>		

**DUAL MICROSWITCH LED & DEVICES DUPLICATED**

**SHEET 6**

**Module Device Codes**

ISSUE	MOD No.	REASON - INITIAL - DATE
1	ACN0127	INTRODUCTION RNP 20-08-2023

Resistor	ExxxR	SxxxR
Diode	ED1	SD1
Zener Diode	ExxxZ	SxxxZ
LED	N/A	L or C

GNEXCP7-BG[s][t][l][e][m][d][v][o][x]-[u][e][s]  
 Switch Type [s] Terminals [t] Product Version [v] Product Option [o] LED Indicator [u] Series Module [s] EOL Module [e]

Notes:  
 1. Units have the option to remove the LED current-limiting resistor RL1 option 'L' using LED option 'C'. In all other cases shown RL1 is included.

**DUAL SWITCH WITH LED, EOL & SERIES DEVICES DUPLICATED**

**CONFIG. P6-1**

**DUAL SWITCH WITH LED, EOL & ALT. SERIES DEVICES DUPLICATED**

**CONFIG. P6-2**

SWITCH TYPE [s] [D] Dual  
 TERMINALS [t] [P] PCB Version  
 PRODUCT OPTION [o] [2] Duplicate EOL/Series  
 LED INDICATOR [u] [L] LED with RL1  
 MODULES [e][s] [Exxxx][Sxxxx] EOL + Series

SWITCH TYPE [s] [D] Dual  
 TERMINALS [t] [P] PCB Version  
 PRODUCT OPTION [o] [Y] Alt. EOL Pos'n duplicated  
 LED INDICATOR [u] [L] LED with RL1  
 MODULES [e][s] [Exxxx][Sxxxx] EOL + Series

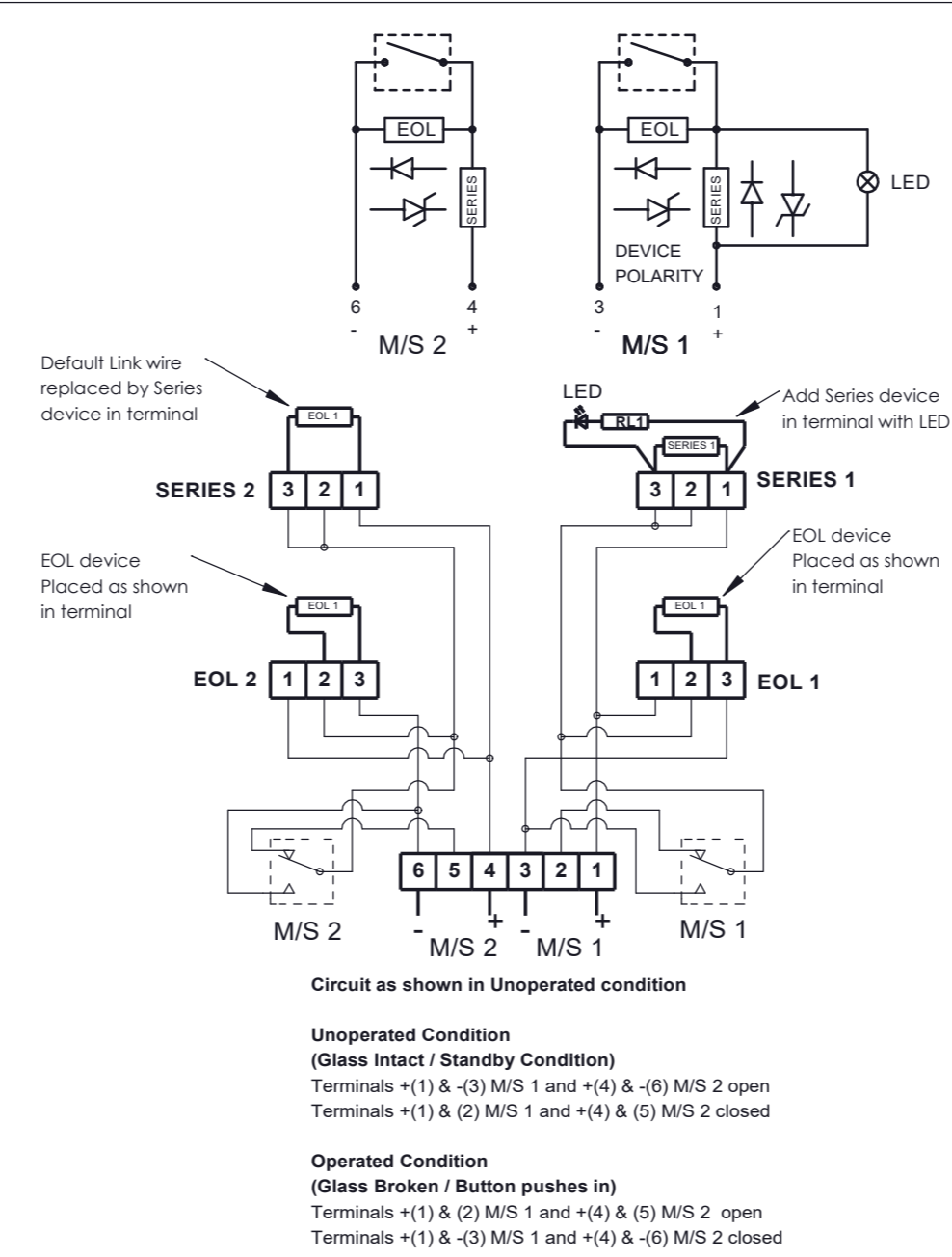
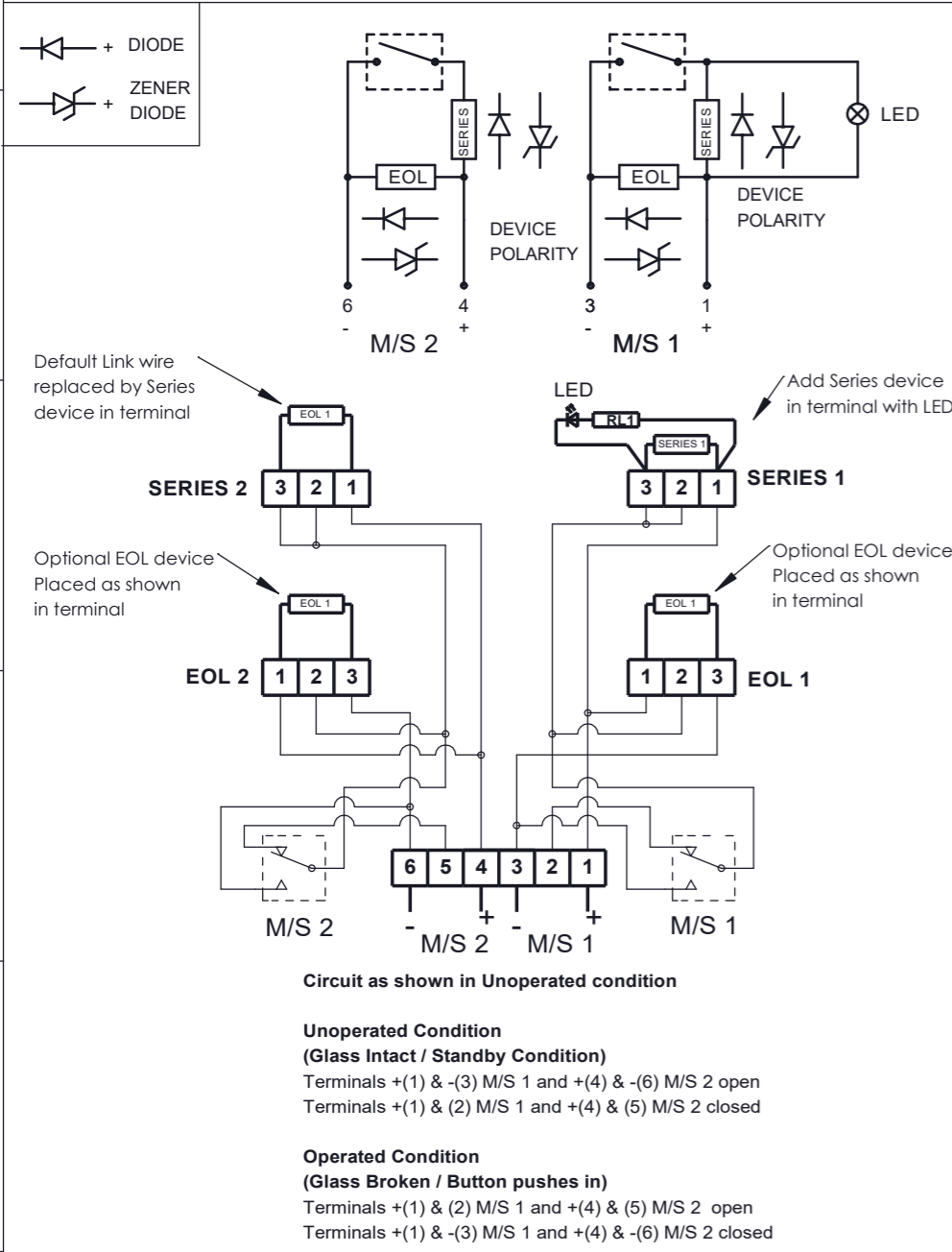

DRAWING TO BS8888:2000  
 GEOMETRIC TOLERANCES TO ISO1101:1983  
 LINEAR DIMENSIONAL TOLS  
 ANGULAR DIMENSIONAL TOLS

STANDARDS  
**GNExCP7 ; STExCP8 ; WP7 units with PCB**

DRAWN	R.N.POTTS	DATE	20-08-2023
CHECKED	B.ISARD	DATE	20-08-2023
APPROVED	R.N.POTTS	DATE	20-08-2023

SURFACE FINISH	WEIGHT (Kg)
MATERIAL	
ALTERNATIVE MATERIAL	

THIS DRAWING AND ANY INFORMATION OR DESCRIPTIVE MATTER THEREIN IS COMMUNICATED IN CONFIDENCE AND IS THE COPYRIGHT PROPERTY OF EUROPEAN SAFETY SYSTEMS LTD. NEITHER THE WHOLE OR ANY EXTRACT MAY BE DISCLOSED, LOANED, COPIED OR USED FOR MANUFACTURING OR TENDERING PURPOSES WITHOUT THEIR WRITTEN CONSENT.

© EUROPEAN SAFETY SYSTEMS LTD. AS PER LATEST DATE OF ISSUE SHOWN ABOVE

EUROPEAN SAFETY SYSTEMS LTD  
 IMPRESS HOUSE  
 MANSELL ROAD  
 ACTON  
 LONDON W3 7QH  
 WWW.E2S.COM

ALL DIMENSIONS IN MM IF IN DOUBT, ASK - DO NOT SCALE				<b>A3</b>
TITLE <b>GNExCP7 ; STExCP8 ; WP7 CALL POINT WIRING / CIRCUIT OPERATION DIAGRAM</b>				
SCALE	SHEET	DRAWING NUMBER		
NTS	6 OF 8	<b>D202-06-212</b>		

# DUAL MICROSWITCH IN PARALLEL, & DEVICES

# SHEET 7

GNEXCP7-BG[s][t][l][e][m][d][v][o][x]-[u][e][s] LED Indicator [u]  
 Switch Type [s] Product Version [v] Product Option [o] EOL Module [e] Series Module [s]  
 Terminals [t]

Module Device Codes		
	EOL	Series
Resistor	ExxxR	SxxxR
Diode	ED1	SD1
Zener Diode	ExxxZ	SxxxZ
LED	N/A	L or C

ISSUE	MOD No.	REASON - INITIAL - DATE
1	ACN0127	INTRODUCTION RNP 20-08-2023

Notes:  
 1. Units have the option to remove the LED current-limiting resistor RL1 option 'L' using LED option 'C'. In all other cases shown RL1 is included.

DUAL SWITCH PARALLEL	CONFIG. P7-1	DUAL SWITCH, PARALLEL WITH EOL & SERIES DEVICES	CONFIG. P7-2	DUAL SWITCH, PARALLEL WITH EOL & ALT. SERIES DEVICES	CONFIG. P7-3
----------------------	--------------	---	--------------	--	--------------

SWITCH TYPE [s] [D] TERMINALS [t] [P] PRODUCT OPTION [o] [P] LED INDICATOR [u] [N]	Dual PCB Version Parallel Wiring No LED	SWITCH TYPE [s] [D] TERMINALS [t] [P] PRODUCT OPTION [o] [P] LED INDICATOR [u] [N] MODULES [e][s] [Exxxx][Sxxxx]	Dual PCB Version Parallel Wiring No LED EOL + Series	SWITCH TYPE [s] [D] TERMINALS [t] [P] PRODUCT OPTION [o] [V] LED INDICATOR [u] [N] MODULES [e][s] [Exxxx][Sxxxx]	Dual PCB Version Parallel Wiring Alt. EOL Pos'n. No LED EOL + Series
---	--	--	--	--	--

Note :- Use when EOL and/or series devices are fitted during installation, or if no series devices are required.

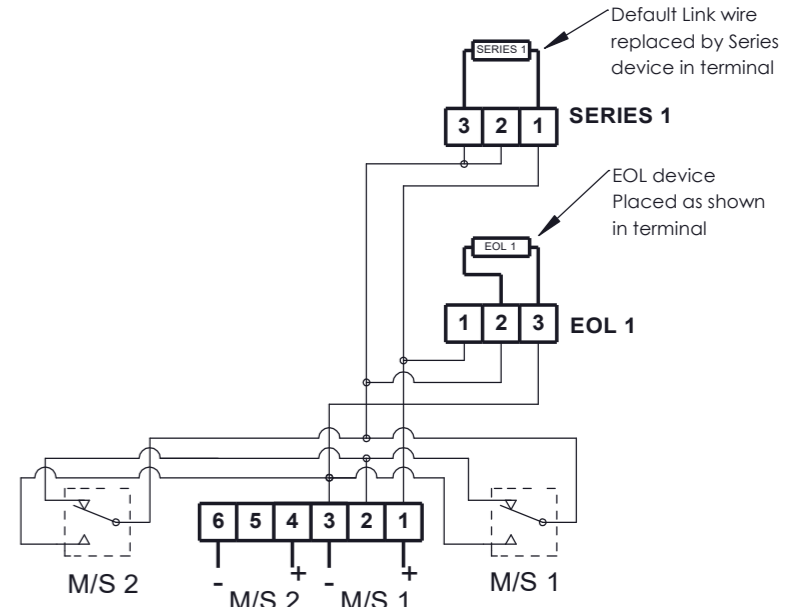
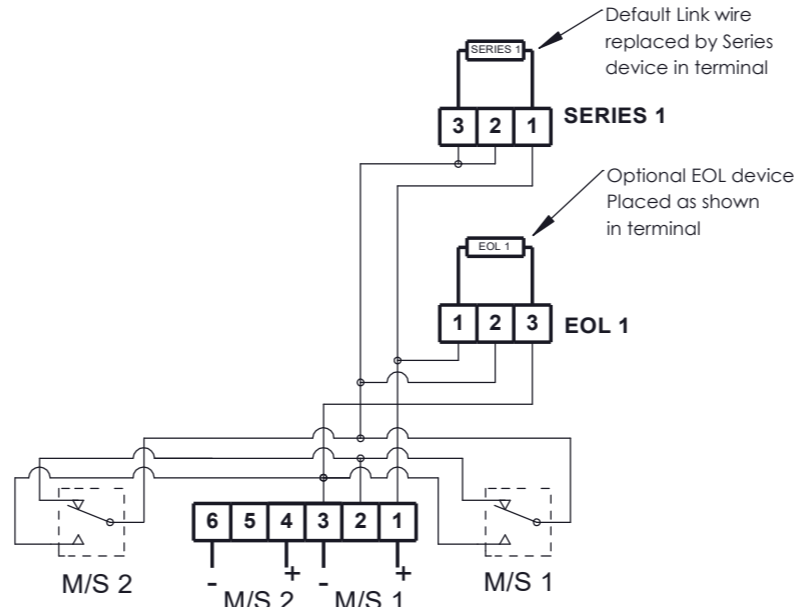
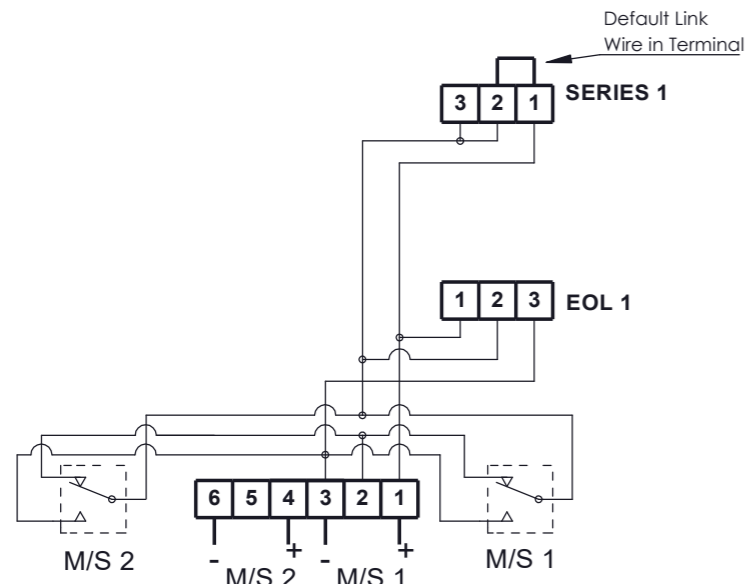
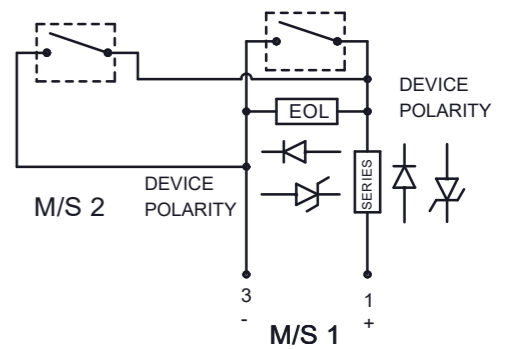
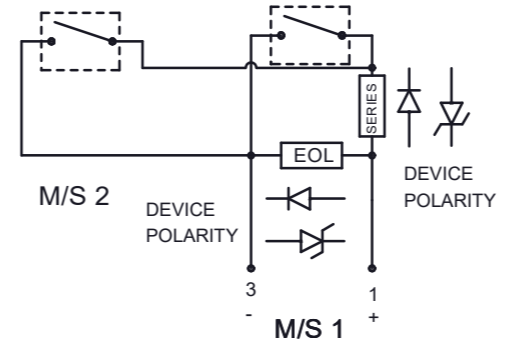
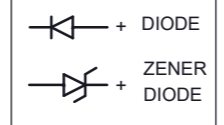
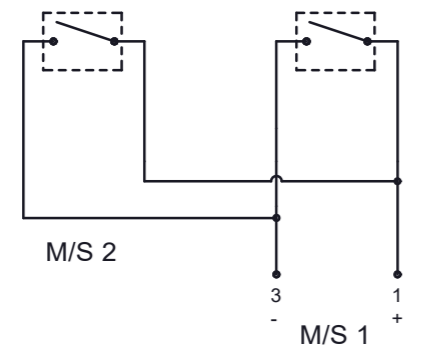

**Circuit as shown in Unoperated condition**

**Unoperated Condition (Glass Intact / Standby Condition)**  
 Terminals +(1) & -(3) M/S 1 and +(4) & -(6) M/S 2 open  
 Terminals +(1) & (2) M/S 1 and +(4) & (5) M/S 2 closed

**Operated Condition (Glass Broken / Button pushes in)**  
 Terminals +(1) & (2) M/S 1 and +(4) & (5) M/S 2 open  
 Terminals +(1) & -(3) M/S 1 and +(4) & -(6) M/S 2 closed

**Circuit as shown in Unoperated condition**

**Unoperated Condition (Glass Intact / Standby Condition)**  
 Terminals +(1) & -(3) M/S 1 and +(4) & -(6) M/S 2 open  
 Terminals +(1) & (2) M/S 1 and +(4) & (5) M/S 2 closed

**Operated Condition (Glass Broken / Button pushes in)**  
 Terminals +(1) & (2) M/S 1 and +(4) & (5) M/S 2 open  
 Terminals +(1) & -(3) M/S 1 and +(4) & -(6) M/S 2 closed

**Circuit as shown in Unoperated condition**

**Unoperated Condition (Glass Intact / Standby Condition)**  
 Terminals +(1) & -(3) M/S 1 and +(4) & -(6) M/S 2 open  
 Terminals +(1) & (2) M/S 1 and +(4) & (5) M/S 2 closed

**Operated Condition (Glass Broken / Button pushes in)**  
 Terminals +(1) & (2) M/S 1 and +(4) & (5) M/S 2 open  
 Terminals +(1) & -(3) M/S 1 and +(4) & -(6) M/S 2 closed

DRAWING TO BS8888:2000  
 GEOMETRIC TOLERANCES TO ISO1101:1983  
 LINEAR DIMENSIONAL TOLS  
 ANGULAR DIMENSIONAL TOLS

DRAWN	R.N.POTTS	DATE	20-08-2023
CHECKED	B.ISARD	DATE	20-08-2023
APPROVED	R.N.POTTS	DATE	20-08-2023

SURFACE FINISH	WEIGHT (Kg)
MATERIAL	
ALTERNATIVE MATERIAL	

THIS DRAWING AND ANY INFORMATION OR DESCRIPTIVE MATTER THEREIN IS COMMUNICATED IN CONFIDENCE AND IS THE COPYRIGHT PROPERTY OF EUROPEAN SAFETY SYSTEMS LTD. NEITHER THE WHOLE OR ANY EXTRACT MAY BE DISCLOSED, LOANED, COPIED OR USED FOR MANUFACTURING OR TENDERING PURPOSES WITHOUT THEIR WRITTEN CONSENT.

© EUROPEAN SAFETY SYSTEMS LTD. AS PER LATEST DATE OF ISSUE SHOWN ABOVE

EUROPEAN SAFETY SYSTEMS LTD  
 IMPRESS HOUSE  
 MANSELL ROAD  
 ACTON  
 LONDON W3 7QH  
 WWW.E2S.COM

ALL DIMENSIONS IN MM IF IN DOUBT, ASK - DO NOT SCALE				<b>A3</b>
TITLE <b>GNEXCP7 ; STExCP8 ; WP7 CALL POINT WIRING / CIRCUIT OPERATION DIAGRAM</b>				
SCALE	SHEET	DRAWING NUMBER		
NTS	7 OF 8	<b>D202-06-212</b>		

**DUAL MICROSWITCH IN PARALLEL, LED & DEVICES**

**SHEET 8**

GNEXCP7-BG[s][t][l][e][m][d][v][o][x]-[u][e][s] Series  
 Switch Type [s] Product Version [v] Product Option [o] EOL Module [e]  
 Terminals [t] LED Indicator [u]

Module Device Codes		
	EOL	Series
Resistor	ExxxR	SxxxR
Diode	ED1	SD1
Zener Diode	ExxxZ	SxxxZ
LED	N/A	L or C

ISSUE	MOD No.	REASON - INITIAL - DATE
1	ACN0127	INTRODUCTION RNP 20-08-2023

Notes:  
 1. Units have the option to remove the LED current-limiting resistor RL1 option 'L' using LED option 'C'. In all other cases shown RL1 is included.

<b>DUAL SWITCH PARALLEL WITH LED</b>	<b>CONFIG. P8-1</b>	<b>DUAL SWITCH PARALLEL WITH LED, EOL &amp; SERIES DEVICES</b>	<b>CONFIG. P8-2</b>	<b>DUAL SWITCH PARALLEL WITH LED, EOL &amp; ALT. SERIES DEVICES</b>	<b>CONFIG. P8-3</b>
--------------------------------------	---------------------	--	---------------------	---	---------------------

SWITCH TYPE [s] [D] TERMINALS [t] [P] PRODUCT OPTION [o] [P] LED INDICATOR [u] [L]	Dual PCB Version Parallel Wiring LED with RL1	SWITCH TYPE [s] [D] TERMINALS [t] [P] PRODUCT OPTION [o] [P] LED INDICATOR [u] [L] MODULES [e][s]	Dual PCB Version Parallel Wiring LED with RL1 EOL + Series	SWITCH TYPE [s] [D] TERMINALS [t] [P] PRODUCT OPTION [o] [V] LED INDICATOR [u] [L] MODULES [e][s]	Dual PCB Version Parallel Wiring Alt. EOL Pos'n. LED with RL1 EOL + Series
---	--	---	--	---	--

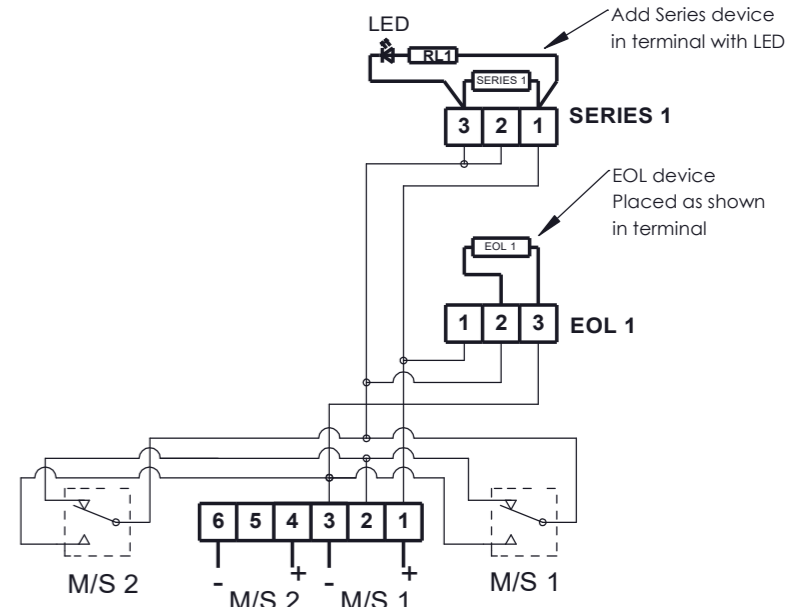
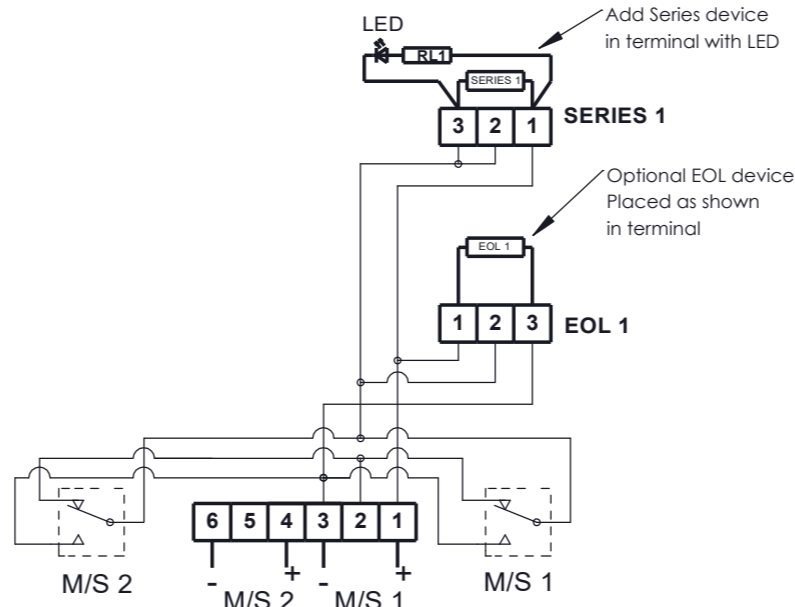
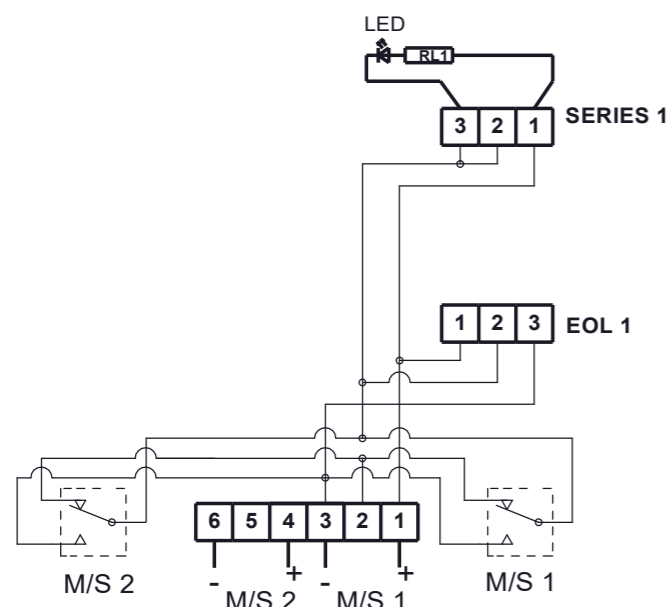
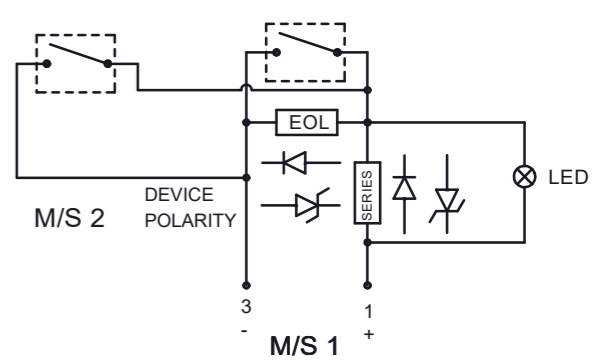
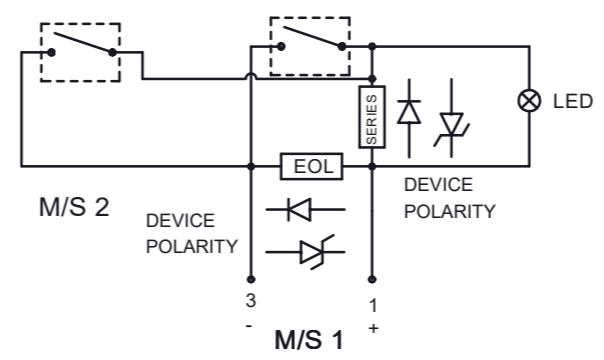
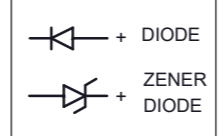
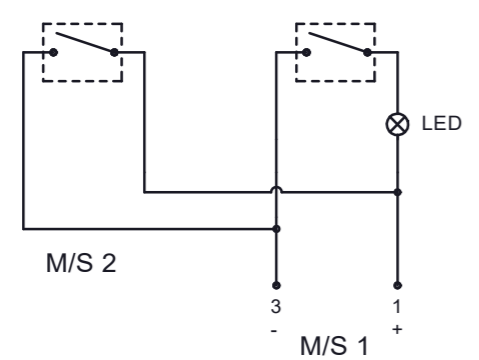

**Circuit as shown in Unoperated condition**

**Unoperated Condition (Glass Intact / Standby Condition)**  
 Terminals +(1) & -(3) M/S 1 and +(4) & -(6) M/S 2 open  
 Terminals +(1) & (2) M/S 1 and +(4) & (5) M/S 2 closed

**Operated Condition (Glass Broken / Button pushes in)**  
 Terminals +(1) & (2) M/S 1 and +(4) & (5) M/S 2 open  
 Terminals +(1) & -(3) M/S 1 and +(4) & -(6) M/S 2 closed

**Circuit as shown in Unoperated condition**

**Unoperated Condition (Glass Intact / Standby Condition)**  
 Terminals +(1) & -(3) M/S 1 and +(4) & -(6) M/S 2 open  
 Terminals +(1) & (2) M/S 1 and +(4) & (5) M/S 2 closed

**Operated Condition (Glass Broken / Button pushes in)**  
 Terminals +(1) & (2) M/S 1 and +(4) & (5) M/S 2 open  
 Terminals +(1) & -(3) M/S 1 and +(4) & -(6) M/S 2 closed

**Circuit as shown in Unoperated condition**

**Unoperated Condition (Glass Intact / Standby Condition)**  
 Terminals +(1) & -(3) M/S 1 and +(4) & -(6) M/S 2 open  
 Terminals +(1) & (2) M/S 1 and +(4) & (5) M/S 2 closed

**Operated Condition (Glass Broken / Button pushes in)**  
 Terminals +(1) & (2) M/S 1 and +(4) & (5) M/S 2 open  
 Terminals +(1) & -(3) M/S 1 and +(4) & -(6) M/S 2 closed

DRAWING TO BS8888:2000  
 GEOMETRIC TOLERANCES TO ISO1101:1983  
 LINEAR DIMENSIONAL TOLS  
 ANGULAR DIMENSIONAL TOLS

STANDARDS  
**GNExCP7 ; STExCP8 ; WP7 units with PCB**

DRAWN	DATE
R.N.POTTS	20-08-2023
CHECKED	DATE
B.ISARD	20-08-2023
APPROVED	DATE
R.N.POTTS	20-08-2023

SURFACE FINISH	WEIGHT (Kg)
MATERIAL	
ALTERNATIVE MATERIAL	

THIS DRAWING AND ANY INFORMATION OR DESCRIPTIVE MATTER THEREIN IS COMMUNICATED IN CONFIDENCE AND IS THE COPYRIGHT PROPERTY OF EUROPEAN SAFETY SYSTEMS LTD. NEITHER THE WHOLE OR ANY EXTRACT MAY BE DISCLOSED, LOANED, COPIED OR USED FOR MANUFACTURING OR TENDERING PURPOSES WITHOUT THEIR WRITTEN CONSENT.

© EUROPEAN SAFETY SYSTEMS LTD. AS PER LATEST DATE OF ISSUE SHOWN ABOVE

EUROPEAN SAFETY SYSTEMS LTD  
 IMPRESS HOUSE  
 MANSELL ROAD  
 ACTON  
 LONDON W3 7QH  
 WWW.E2S.COM

ALL DIMENSIONS IN MM IF IN DOUBT, ASK - DO NOT SCALE			<b>A3</b>
TITLE <b>GNExCP7 ; STExCP8 ; WP7 CALL POINT WIRING / CIRCUIT OPERATION DIAGRAM</b>			
SCALE	SHEET	DRAWING NUMBER	
NTS	8 OF 8	<b>D202-06-212</b>	



# EU Declaration of Conformity



Manufacturer: European Safety Systems Ltd.  
Impress House, Mansell Road, Acton  
London, W3 7QH  
United Kingdom

Authorised Representative: E2S Warnsignaltechnik UG  
Charlottenstrasse 45-51  
72764 Reutlingen  
Germany

Equipment Type: GNExCP7-BG-S, GNExCP7-BG-D, GNExCP7-BG-S-L or C, GNExCP7-BG-D-L or C  
GNExCP7-PB-S, GNExCP7-PM-S, GNExCP7-PT-S,  
GNExCP7-PB-S-L or C, GNExCP7-PM-S-L or C, GNExCP7-PT-S-L or C,  
GNExCP7-PB-D, GNExCP7-PM-D, GNExCP7-PT-D  
GNExCP7-PB-D-L or C, GNExCP7-PM-D-L or C, GNExCP7-PT-D-L or C

---

## Directive 2014/34/EU: Equipment and Protective Systems for use in Potentially Explosive Atmospheres (ATEX)

Notified Body for EU type Examination (Module B):	UL International Demko A/S Notified Body No.: 0539 Borupvang 5A, 2750 Ballerup, Denmark
EU-type Examination Certificate (Module B):	DEMKO 19 ATEX 2101X
Notified Body for Quality Assurance Notification / Conformity to EU-type based on quality assurance of the production process (Module D):	Sira Certification Service Notified Body No.: 2813 CSA Group Netherlands B.V, Utrechtseweg 310, 6812 AR, Arnhem, Netherlands
Quality Assurance Notification (Module D):	SIRA 05 ATEX M342
Provisions fulfilled by the equipment:	II 2G Ex d IIC T6...T4 Gb II 2D Ex tb IIIC T100°C...T80°C Db
Standards applied:	EN 60079-0:2018 EN 60079-1:2014 EN 60079-31:2014 IP6X Dust Protection to EN60079-0 / EN60079-31

## Directive 2014/30/EU: Electromagnetic Compatibility Directive (EMC)

Standards applied:	EN 61000-6-1:2007 EN 61000-6-2:2005 EN 61000-6-3:2007 / A1:2011 / AC: 2012 EN 61000-6-4:2007 / A1: 2011
--------------------	--

## Directive 2011/65/EU: Restriction of the use of certain hazardous substances in electrical and electronic equipment (RoHS)

The product and all the components contained within it are in accordance with the restriction of the use of hazardous substances in electrical and electronic equipment, including amendment by Directive 2015/863/EU.

## Regulation (EC) 1907/2006: Registration, Evaluation, Authorisation and Restriction of Chemicals (REACH)

The product and all the components contained within it are free from substances of very high concern.

## Other Standards and Regulations

EN 60529:1991 + A1:2000 + A2:2013. - Degrees of protection provided by enclosures (IP code) – enclosure rated IP66/67/68

A handwritten signature in black ink, appearing to read 'Martin Streetz', written over a light blue circular stamp.

Martin Streetz  
Quality Assurance Manager

Document No.: DC-078\_Issue\_F  
Date and Place of Issue: London, 14/09/2023

# EU Declaration of Conformity



---

On behalf of European Safety Systems Ltd., I declare that, on the date the equipment accompanied by this declaration is placed on the market, the equipment conforms with all technical and regulatory requirements of the above listed directives, regulations and standards.

This Declaration is issued under the sole responsibility of the manufacturer.

A handwritten signature in black ink, appearing to read 'Martin Streetz', written over a faint, illegible background.

Martin Streetz  
Quality Assurance Manager

Document No.:  
Date and Place of Issue:

DC-078\_Issue\_F  
London, 14/09/2023



# UKCA Declaration of Conformity



**Manufacturer:** European Safety Systems Ltd.  
Impress House, Mansell Road, Acton  
London, W3 7QH  
United Kingdom

**Equipment Type:** GNExCP7-BG-S, GNExCP7-BG-D, GNExCP7-BG-S-L or C, GNExCP7-BG-D-L or C  
GNExCP7-PB-S, GNExCP7-PM-S, GNExCP7-PT-S,  
GNExCP7-PB-S-L or C, GNExCP7-PM-S-L or C, GNExCP7-PT-S-L or C,  
GNExCP7-PB-D, GNExCP7-PM-D, GNExCP7-PT-D  
GNExCP7-PB-D-L or C, GNExCP7-PM-D-L or C, GNExCP7-PT-D-L or C

Directive UKSI 2016:1107 (as amended by UKSI 2019:696) – Schedule 3A, Part 1 : Product or Protective System Intended for use in Potentially Explosive Atmospheres (UKCA)

**Notified Body for UK type Examination (Module B):** UL International (UK) Ltd  
Notified Body No.: 0843  
Unit 1-3 Horizon Kingsland Business Park, Wade Road,  
Basingstoke, Hampshire RG24 8AH UK

**UK-type Examination Certificate (Module B):** UL21UKEX2134X

**Notified Body for Quality Assurance Notification / Conformity to EU-type based on quality assurance of the production process (Module D):** Sira Certification Service  
Notified Body No.: 0518  
Rake Lane, Eccleston, Chester CH4 9JN, UK

**Quality Assurance Notification (Module D):** CSAE 22UKQAN0046

**Provisions fulfilled by the equipment:** II 2G Ex d IIC T6...T4 Gb  
II 2D Ex tb IIIC T100°C... T80°C Db

**Standards applied:** EN 60079-0:2018  
EN 60079-1:2014  
EN 60079-31:2014  
IP6X Dust Protection to EN60079-0 / EN60079-31

Directive 2014/30/EU: Electromagnetic Compatibility Directive (EMC)

**Standards applied:** EN 61000-6-1:2007  
EN 61000-6-2:2005  
EN 61000-6-3:2007 / A1:2011 / AC: 2012  
EN 61000-6-4:2007 / A1: 2011

Directive 2011/65/EU: Restriction of the use of certain hazardous substances in electrical and electronic equipment (RoHS)

The product and all the components contained within it are in accordance with the restriction of the use of hazardous substances in electrical and electronic equipment, including amendment by Directive 2015/863/EU.

Regulation (EC) 1907/2006: Registration, Evaluation, Authorisation and Restriction of Chemicals (REACH)

The product and all the components contained within it are free from substances of very high concern.

Other Standards and Regulations

EN 60529:1991 + A1:2000 + A2:2013. - Degrees of protection provided by enclosures (IP code) – enclosure rated IP66/67/68

On behalf of European Safety Systems Ltd., I declare that, on the date the equipment accompanied by this declaration is placed on the market, the equipment conforms with all technical and regulatory requirements of the above listed directives, regulations and standards.

This Declaration is issued under the sole responsibility of the manufacturer.

Martin Streetz  
Quality Assurance Manager

Document No.: DC-099\_Issue\_B  
Date and Place of Issue: London, 14/09/2023