



D1xCP1-PS SERIES

EXPLOSION PROOF MANUAL PULL STATIONS

The D1xCP1-PS Series of Explosion Proof Manual Pull Stations is UL and FM listed for use in hazardous environments, and for Nema Type 4X weatherproof applications. The unit also complies with ADA standards when installed at less than 48 inches above the floor for front wheelchair access, and less than 54 inches for side wheelchair access. All installations must comply with local codes and regulations.

Ratings: **UL Listed**

Enclosure: Class I, Groups B, C, and D. Class II, Groups E, F, and G. Class III.
Type 4X (Weatherproof), MARINE.

Contacts: D.P.D.T 10 Amps, 120 VAC
1 Amp, 30 VDC

Installation:

(Please refer to assembly diagram and installation notes on the back side)

The D1xCP1-PS model station includes a front housing, a back box, a switch plate, and all the necessary hardware to assemble the station.

1. Install the back box onto its mounting surface using the 4 holes provided on the mounting tabs. The tabs are designed to accept a screw size of up to 1/4".
2. The back box is supplied with two 3/4"-14 NPT conduit entries. Threaded joints between conduit and back box must be made with a minimum of 5 threads fully engaged. Seal unused conduit entry with a UL listed close-up plug for use in the hazardous locations listed above. Joint sealing material may be used if it is of the type that does not harden because of aging, contain an evaporating solvent, or cause corrosion of the joint surfaces.
3. Connect the field wiring to the terminal blocks on the adaptor plate. Use the insulated terminal lug supplied to ground the box properly. Each wire or terminal lug must be placed under its corresponding clamping plate for proper connection.
4. Install the switch plate onto the back box using the 4 1/4"-20x7/8 pan head screws provided. Make sure that the o-ring seals on the screws and around the edge of the switch plate are properly seated.
5. Open the front housing, align its mounting plate with the pins provided on the switch plate and attach it using the two 6-32 screws provided into the slotted holes.

Installation Diagram

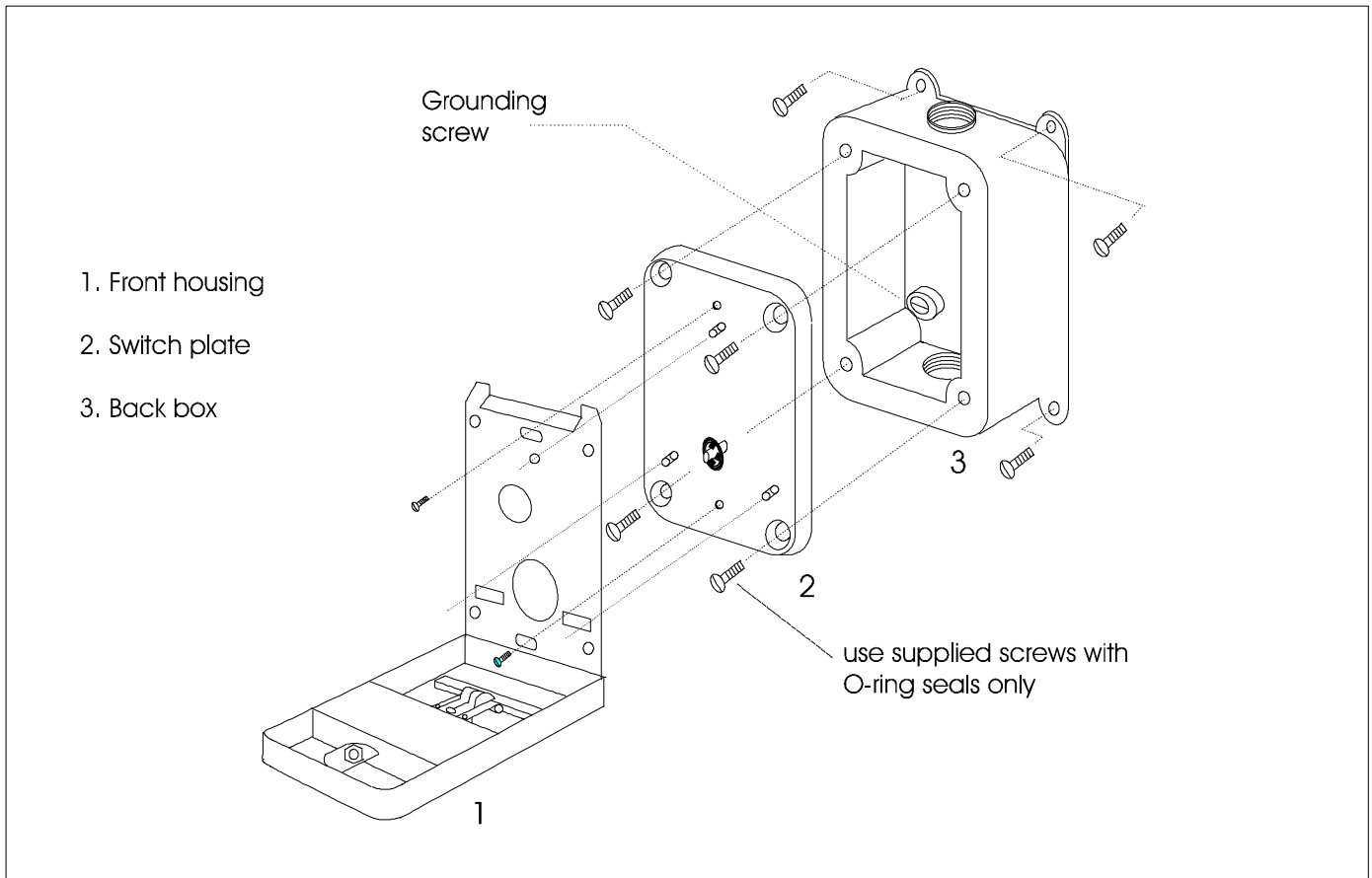

Caution:

Before beginning, verify that the supply is turned off.
Take care not to scratch or damage the surfaces of the flange joint.

Terminal Block Layout

1. Check to make sure that the flange surfaces are completely clean and free of scratches, debris and dust.
2. Verify that the O-ring seals on the 4 7/8 screws and the gasket around the inside surface of the switch plate are properly seated.
3. Seal unused conduit entry with a 3/4" NPT plug.
4. Connect the ground wire to the grounding screw in the back box.
5. After tightening the 4 switch plate bolts, verify that a 0.0015" feeler gauge does not penetrate more than 1/8" at any point around the flange joint.

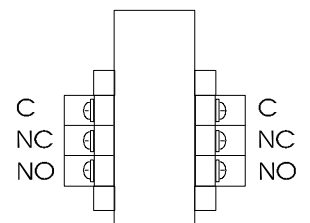

Shown in the upright position