

A

SPECTRA

Buzzer Horn LED Array
IP Rating: IP65
Temp: -25 °C to +50 °C
Unit weight: 184g
CE

Order code Voltage
H100BL030G/x 10-30V DC
• 12V dc 10mA
• 24V dc 24mA

• Beacon Current Consumption
• 12V dc 74mA
• 24V dc 80mA

H100BL230G/x 40-260V AC/DC
• 115V ac 50/60Hz 19mA
• 230V ac 50/60Hz 10mA

• Beacon Current Consumption
• 115V ac 50/60Hz 119mA
• 230V ac 50/60Hz 32mA

H100 BL

Dimensions : 94.2 x 135.2mm
1.5mm² terminals
Cable entry: 1 x 5-7mm push
through grommet

x = Lens colour
R = Red A = Amber
B = Blue C = Clear
G = Green Y = Yellow

Tel: +44 (0)2 8743 8880 Fax: +44 (0)20 8740 4200
mail: sales@e2s.com web: www.e2s.com



D

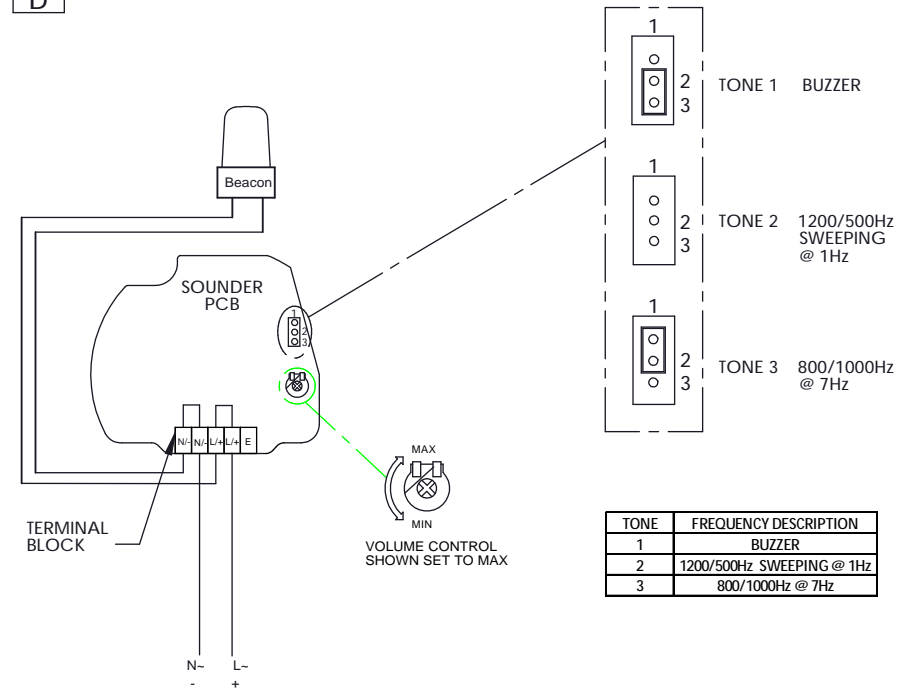

B

- ⚠ ATTENTION:** Installation must be carried out by an electrician in compliance with the latest codes and regulations.
- ⚠ ATTENTION:** Disconnect from power source before installation or service to prevent electric shock.
- ⚠ ATTENTION:** On strobe beacons allow a minimum of 2 minutes for hazardous high voltage to discharge from unit.
- ⚠ ATTENTION:** Lens on unit will be hot allow to cool prior to removal.

C



A SPECTRA H 100 BL

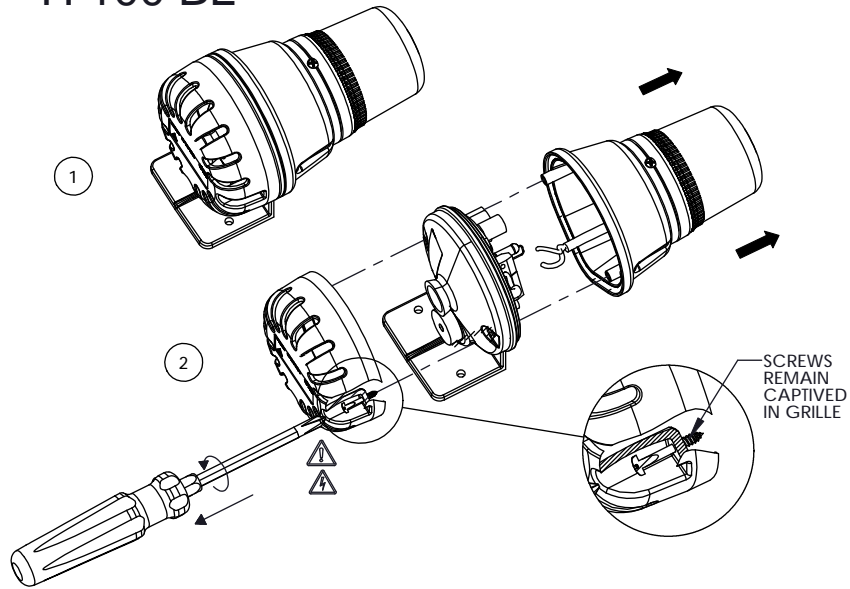

Tel: +44 (0)2 8743 8880 Fax: +44 (0)20 8740 4200
mail: sales@e2s.com web: www.e2s.com



C

PLACE THE HEADER PIN TO REQUIRED TONE
SEE SHEET 1, FOR DETAIL.

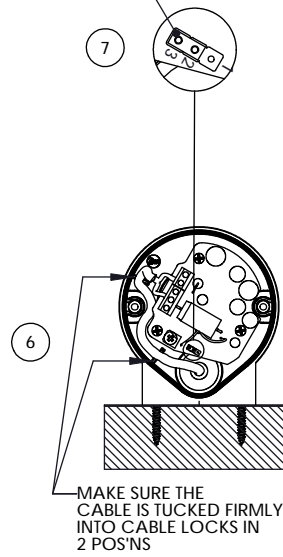

TERMINAL BLOCK	A/C INPUT	D/C INPUT
N/-	N-	-
N/-	N-(FROM BEACON)	-(FROM BEACON)
L/+	L-	+
L/+	L-(FROM BEACON)	+(FROM BEACON)
E		

8 CONNECT THE BEACON CABLES TO TERMINAL AS SHOWN

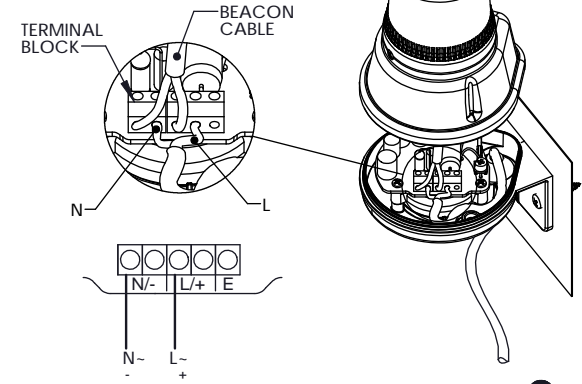

B

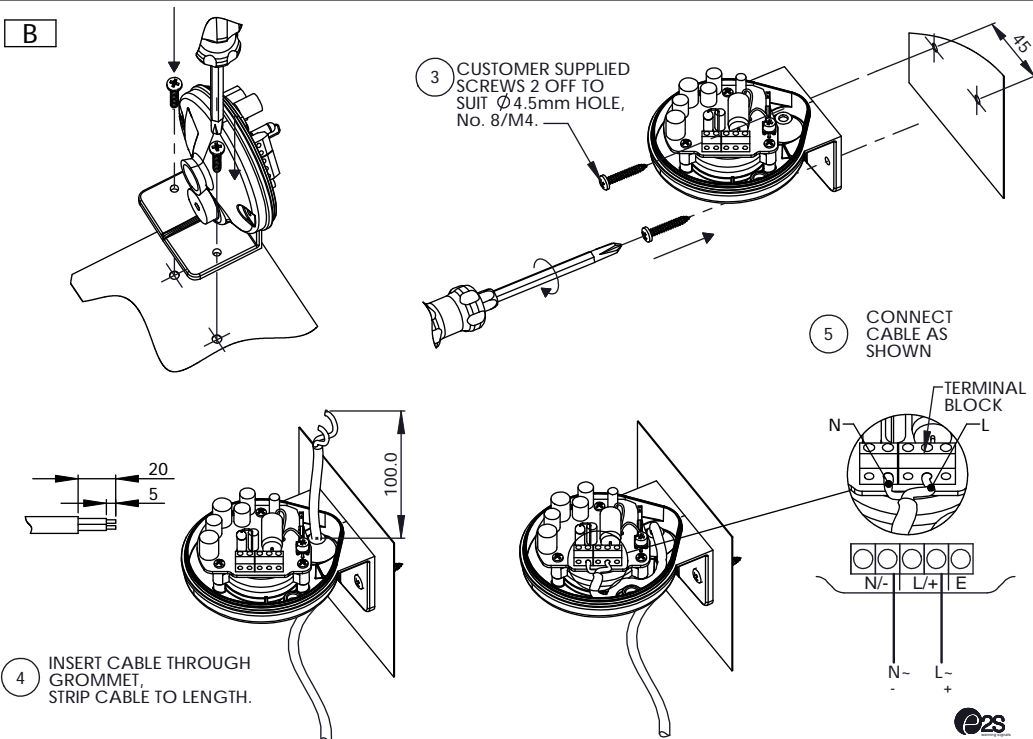

D

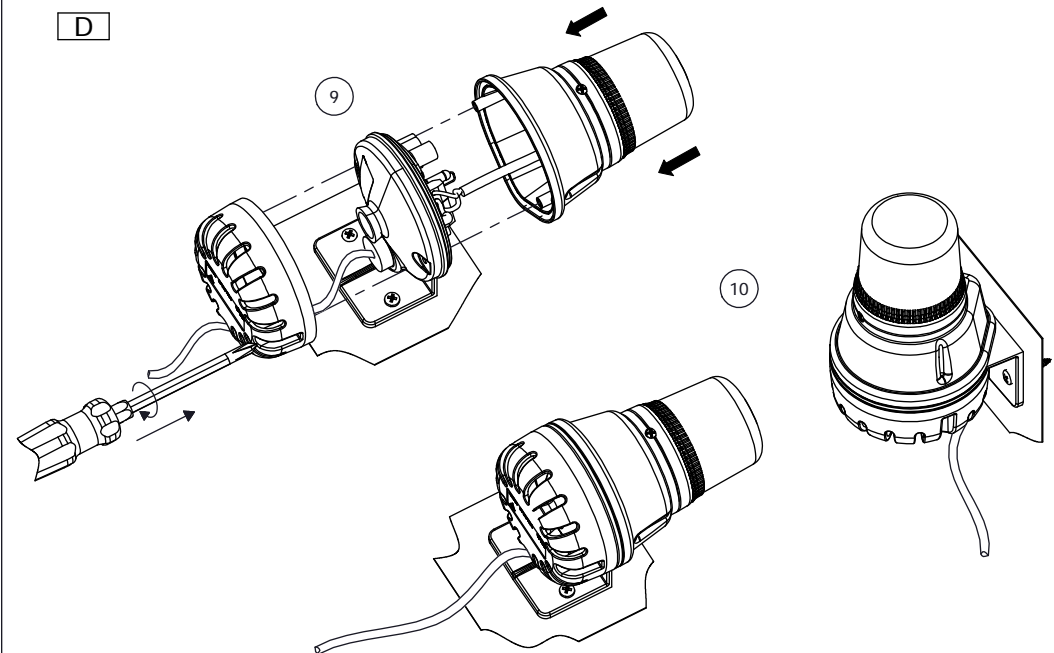

Dimensions in mm

