

Features

- Automatic synchronisation on multi-sounder system.
- Continuously rated.
- Large termination area.
- Stainless steel fixings.
- Ratchet adjustable stainless steel 'U' bracket for 360° positioning.
- Duplicate cable terminations.
(in & out for daisy-chain installations).
- Tropicalisation available on request.
- Available with custom tone configurations and frequencies.
- 'Programmable' version available:
 - 45 alarm tones
 - 4 remotely selectable stages
 - Any tone can be assigned to any stage
 - User configurable continuous frequency tone



Approvals

- GOST-R approved: POCC GBJB05-H00144.

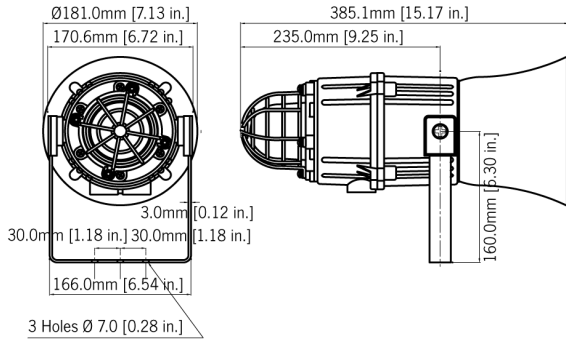

Specification

Sounder:	
Maximum output:	119dB(A) @ 1 metre [110dB(A) @ 10ft/3m]
Nominal output:	112dB(A) @ 1m +/- 3dB - Tone 2 [103dB(A) @ 10ft/3m]
No. of tones:	45 (UKOOA / PFEER compliant)
No. of stages:	3
Volume control:	Max. 112dB(A); Min. 100dB(A) - Tone 2
Effective range:	125m/410ft @ 1KHz
Voltages DC:	24V dc (10-30V dc); 48V dc (35-60V dc) [DC units can use 24V ac for single stage applications.]
Voltages AC:	24V ac; 115V ac; 230V ac
Stage switching:	Negative or positive Reverse polarity stage switching on DC units.
L.E.D. Beacon:	
Light source:	Array of 32 high output L.E.D.s
Peak/Effective Intensity cd:	11 cd* - measured ref. to I.E.S.
Lens colours:	Amber, Blue, Clear (white L.E.D.s) Green, Red & Yellow
Voltages DC:	10-50V dc
Voltages AC:	24V ac; 115V ac; 230V ac
General:	
Ingress protection:	IP66 & IP67 (Third party tested)
Housing material:	High impact UL94 V0 & 5VA FR ABS
Colour:	Grey (RAL7038)
Cable entries:	2 x M20 supplied with 1 blanking plug
Lens material:	Borosilicate glass dome with PC prismatic lens cover.
Guard:	Stainless Steel dome guard as standard
Terminals:	0.5 to 4.0mm ² cables.
Operating temp:	-25 to +55°C [-13° to +131°F]
Storage temp:	-40 to +70°C [-40° to +158°F]
Relative humidity:	90% at 20°C [68°F]
Weight:	DC: 3.00kg/6.6lbs AC: 3.50kg/7.7lbs

*Candela measurements representative of performance with red lens at optimum voltage.

*SPL data +/-3dB(A). Measured at optimum voltage.

Part Codes

Version:	Part code:
12V dc	MCA112L1DC12G-xx
24V dc	MCA112L1DC24G-xx
48V dc	MCA112L1DC48G-xx
24V ac	MCA112L1AC24G-xx
115V ac	MCA112L1AC115G-xx
230V ac	MCA112L1AC230G-xx

[xx] = L.E.D. / Lens
AM: Amber, BL: Blue, CL: Clear, GN: Green, RD: Red, YW: Yellow

Suffix part number with 'P' for programmable, 4 stage, 45 tone version.

Alarm Sounder

Version:	Voltage:	Current:
24V dc	10-30V dc	200mA*
48V dc	35-60V dc	120mA*
24V ac	50/60Hz +/-10%	500mA
115V ac	50/60Hz +/-10%	100mA
230V ac	50/60Hz +/-10%	60mA

* current at nominal voltage on Tone 2

L.E.D. Beacon

Version:	Voltage:	Current:
12V dc	10-50V dc	760mA
24V dc	10-50V dc	400mA
48V dc	10-50V dc	210mA
24V ac	50/60Hz +/-10%	380mA
115V ac	50/60Hz +/-10%	135mA
230V ac	50/60Hz +/-10%	65mA

Beacon modes

Mode:	Stage 1: [Select on board]	Stage 2: [Remote select]	Stage 3: [Remote select]
1	All L.E.D's on	Mode: 9	Mode: 6
2	Rotating: Slow1	Mode: 9	Mode: 1
3	Single Flash: 2Hz	Mode: 7	Mode: 1
4	Rotating: Fast 1	Mode: 3	Mode: 1
5	Rotating: Slow 2	Mode: 6	Mode: 1
6	Double Flash: 1Hz	Mode: 7	Mode: 1

Tone table

S 1	Description	S 2	S 3	S 1	Description	S 2	S 3
T 1	340 Hz Continuous	T 2	T 5	T 33	745Hz @ 1Hz Intermittent	T 2	T 5
T 2	800/1000Hz @ 0.25 sec Alternating	T 17	T 5	T 34	1000 & 2000Hz @ 0.5 sec Alternating - Singapore	T 38	T 45
T 3	500/1200Hz @ 0.3Hz 0.5 sec Slow Whoop	T 2	T 5	T 35	420Hz @ 0.625 sec Australian Alert	T 36	T 5
T 4	800/1000Hz @ 1Hz Sweeping	T 6	T 5	T 36	500-1200Hz 3.75sec /0.25sec. Australian Evac.	T 35	T 5
T 5	2400Hz Continuous	T 3	T 20	T 37	1000Hz Continuous - PFEER Toxic Gas	T 9	T 45
T 6	2400/2900Hz @ 7Hz Sweeping	T 7	T 5	T 38	2000Hz Continuous	T 34	T 45
T 7	2400/2900Hz @ 1Hz Sweeping	T 10	T 5	T 39	800Hz 0.25sec on, 1 sec off Intermittent	T 23	T 17
T 8	500/1200/500Hz @ 0.3Hz Sweeping	T 2	T 5	T 40	544Hz (100mS)/440Hz (400mS) - NF S 32-001	T 31	T 27
T 9	1200/500Hz @ 1Hz - DIN / PFEER P.T.A.P.	T 15	T 2	T 41	Motor Siren - slow rise to 1200 Hz	T 2	T 5
T 10	2400/2900Hz @ 2Hz Alternating	T 7	T 5	T 42	Motor Siren - slow rise to 800 Hz	T 2	T 5
T 11	1000Hz @ 1Hz Intermittent	T 2	T 5	T 43	1200 Hz Continuous	T 2	T 5
T 12	800/1000Hz @ 0.875Hz Alternating	T 4	T 5	T 44	Motor Siren - slow rise to 2400 Hz	T 2	T 5
T 13	2400Hz @ 1Hz Intermittent	T 15	T 5	T 45	1KHz 1s on, 1s off Intermittent - PFEER Gen. ...	T 38	T 34
T 14	800Hz 0.25sec on, 1 sec off Intermittent	T 4	T 5				
T 15	800Hz Continuous	T 2	T 5				
T 16	660Hz 150mS on, 150mS off Intermittent	T 18	T 5				
T 17	544Hz (100mS)/440Hz (400mS) - NF S 32-001	T 2	T 27				
T 18	660Hz 1.8sec on, 1.8sec off Intermittent	T 2	T 5				
T 19	1.4KHz-1.6KHz 1s, 1.6KHz-1.4KHz 0.5s -NFC48-265	T 2	T 5				
T 20	660Hz Continuous	T 2	T 5				
T 21	554Hz/440Hz @ 1Hz Alternating	T 2	T 5				
T 22	544Hz @ 0.875 sec. Intermittent	T 2	T 5				
T 23	800Hz @ 2Hz Intermittent	T 6	T 5				
T 24	800/1000Hz @ 50Hz Sweeping	T 29	T 5				
T 25	2400/2900Hz @ 50Hz Sweeping	T 29	T 5				
T 26	Bell	T 2	T 15				
T 27	554Hz Continuous	T 26	T 5				
T 28	440Hz Continuous	T 2	T 5				
T 29	800/1000Hz @ 7Hz Sweeping	T 7	T 5				
T 30	300Hz Continuous	T 2	T 5				
T 31	660/1200Hz @ 1Hz Sweeping	T 26	T 5				
T 32	Two T chime.	T 26	T 15				