



INSTRUCTION MANUAL (ATEX / IECEx)

BExDL25E and BExDL15E

Flameproof / Increased Safety Loudspeakers

For use in Flammable Gas and Dust Atmospheres

1) Introduction

The BExDL25E and BExDL15E are flameproof / increased safety loudspeakers which are certified to meet the requirements of the ATEX directive 94/9/EC and the IECEx scheme. The loudspeakers can be used in hazardous areas where potentially flammable gas and dust atmospheres may be present. There are four versions of each loudspeaker, 8 ohm or 16 ohm and 70V or 100V Line transformer. On 70V and 100V line transformer units there are four output tapplings for each size of loudspeaker. The BExDL25E unit produces output levels in the 117dB(A) range and the BExDL15E unit produces output levels in the 112dB(A) range. Both loudspeakers can be used in Zone 1 and Zone 2 areas with gases in groups IIA, IIB and IIC and temperature Classifications of T1, T2, T3 and T4. For ambient temperatures over +55°C the gas groups are limited to IIA and IIB. They can also be used in Zone 21 and Zone 22 areas for combustible dusts and have an IP rating of IP 66 and a surface temperature of T115°C based on max Ta of +70°C.

2) Marking

All units have a rating label, which carries the following important information:-

Unit Type No. BExDL25E or BExDL15E

Impedance: 8 ohm or 16 ohm
70V Line or 100V Line

Codes: Ex de IIC T4 for Ta -50°C to +55°C
Ex de IIB T4 for Ta -50°C to +70°C
Ex tD A21 IP66 T115°C based on max. Ta of 70°C

Certificate No's KEMA 99ATEX6312
IECEx KEM 10.0003

Epsilon x:
Equipment Group and
Category:

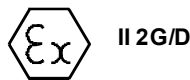

CE Marking:
Notified Body No.

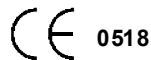

“Warnings” DO NOT OPEN WHEN AN EXPLOSIVE
GAS OR DUST ATMOSPHERE IS PRESENT

COVER BOLTS CLASS A4-80

USE HEAT RESISTING CABLES AND CABLE GLANDS
(Rated 110°C) AT AMB. TEMPERATURES OVER 40°C

Year of Construction /
Serial No.

i.e. 10 / 1DL43000001

3) Type Approval Standards

The loudspeakers have EC Type Examination and IECEx certificates issued by KEMA and have been approved to the following standards:-

EN60079-0:2006	IEC60079-0:2004 (Ed4)	General Requirements
EN60079-1:2007	IEC60079-1:2007 (Ed6)	Flameproof Enclosure 'd'
EN60079-7:2003	IEC60079-7:2001 (Ed3)	Increased Safety 'e'
EN61241-0:2006	IEC61241-0:2004 (Ed1)	Dust General Requirements
EN61241-1:2004	IEC61241-1:2004 (Ed1)	Dust Enclosures 'd'

4) Installation Requirements

The loudspeakers must be installed in accordance with the latest issues of the relevant parts of the EN60079 and IEC60079 standards – Selection, Installation and maintenance of electrical apparatus for use in potentially explosive atmospheres (other than mining applications or explosive processing and manufacture):-

EN60079-14:2008 Electrical Installations in Hazardous
IEC60079-14:2007 (Ed4) Areas (other than mines)

EN60079-10:2003 Classification of Hazardous Areas
IEC60079-10:2008 (Ed1)

The installation of the units must also be in accordance with any local codes that may apply and should only be carried out by a competent electrical engineer who has the necessary training.

5) Zones, Gas Group, Category, IP Rating and Temperature Classification

The BExDL25E and BExDL15E loudspeakers have been certified Ex de IIC T4 for Ta -50°C to +55°C and Ex de IIB T4 for Ta -50°C to +70°C for gas and Ex tD A21 IP66 T115°C based on max. Ta of +70°C for dust. This means that the units can be installed in locations with the following conditions:-

Area Classification Gas:

Zone 1	Explosive gas air mixture likely to occur in normal operation.
Zone 2	Explosive gas air mixture not likely to occur, and if it does, it will only exist for a short time.

Gas Groupings:

Group IIA	Propane
Group IIB	Ethylene
Group IIC (Up to +55°C only)	Hydrogen and Acetylene

Temperature Classification:

T1	400°C
T2	300°C
T3	200°C
T4	135°C

Area Classification Dust:

Zone 21	Explosive dust air mixture likely to occur in normal operation.
Zone 22	Explosive dust air mixture not likely to occur, and if it does, it will only exist for a short time.

IP Rating: IP66 T100°C Ta ≤ +55°C
 T115°C Ta ≤ +70°C

Equipment Category: 2G/D

Ambient Temperature Range:

-50°C to +55°C Gas Groups IIA, IIB and IIC
 -50°C to +70°C Gas Group IIA and IIB

6) Loudspeaker Location and Mounting

The location of the loudspeakers should be made with due regard to the area over which the unit must be audible. The loudspeakers should only be fixed to services that can carry the weight of the unit.

The loudspeakers should be securely bolted to a suitable surface using the 7mm diameter boltholes in the stainless steel U shaped mounting bracket (see figure 1). The angle can then be adjusted in the direction that the sound is primarily required to cover. This can be achieved by loosening the two large bracket screws in the side of the unit, which allow adjustment in steps of 18°. On completion of the installation the two large bracket adjustment screws on the side of the unit must be fully tightened to ensure that the loudspeaker cannot move in service.

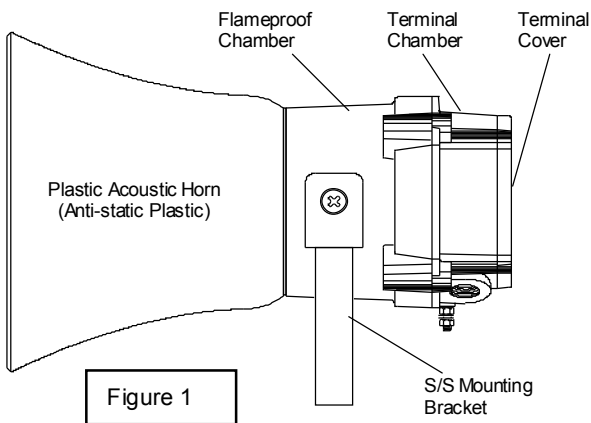

Figure 1

7) Access to the Flameproof Enclosure

Access to the flameproof enclosure will not normally be necessary as the cables enter the unit in the Ex 'e' Increased Safety Termination enclosure. Access will only be required if you need to fit an end on line monitoring component (see

section 15 of this manual). To gain access to the flameproof enclosure, remove the four M6 hexagon socket head screws (see figure 2) and withdraw the terminal chamber taking extreme care not to damage the flameproof joints in the process.

Note the four **M6 screws are Class A4-80 stainless steel and only screws of this category can be used on these loudspeakers.** It is therefore important that these screws and their spring washers are kept in a safe place during installation.

On completion of the fitting of the monitoring component the flameproof joints should be inspected to ensure that they are clean and that they have not been damaged during installation. Also check that the earth bonding wire between the two casting sections is secure and that the 'O' ring seal is in place. When replacing the terminal chamber section casting, ensure that it is square with the flameproof chamber casting before inserting. Carefully push the section in place allowing time for the air to be expelled. Only after the section is fully in place should the four M6 Stainless Steel A4-80 cover bolts and their spring washers be inserted and tightened down. If the section jams while it is being inserted, carefully remove it and try again. Never use the M6 cover bolts to force the cover into position.

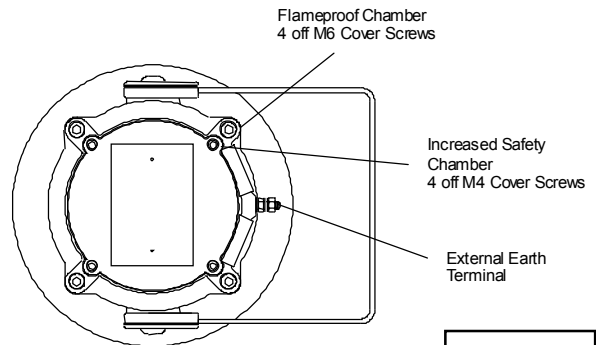

Figure 2

8) Access to the Increased Safety Terminal Chamber

To connect the cables to the loudspeaker it is necessary to remove the terminal cover to gain access to the termination chamber. To achieve this remove the four M4 hexagon socket head screws (see figure 2).

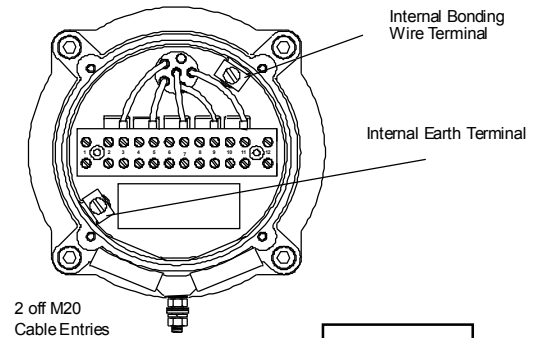

Figure 3

The four M4 screws and their spring washers are grade A4 stainless steel and they should be kept in a safe place during

installation. Before replacing the terminal cover ensure that the earth bonding wire between the two castings is secure and that the 'O' ring seal is in place. Insert the four M4 hexagon screws and their spring washers and tighten them down.

9) Power Amplifier Selection

It is important that the loudspeakers are connected to power amplifiers that have outputs that are compatible to the type of loudspeaker being used. Loudspeakers with a 70V or 100V line matching transformer fitted must be connected to a power amplifier with a 70V or 100V line output. Low impedance 8 ohm or 16 ohm loudspeakers must be connected to amplifiers with a suitable low impedance output.

The following table shows the range of loudspeakers:-

Unit Type	Input	Wattage	Max. I/P Volts
BExDL25E	100V Line	25W	100V
BExDL25E	70V Line	25W	70V
BExDL25E	8 ohm	25W	14.14V
BExDL25E	16 ohm	25W	20V
BExDL15E	100V Line	15W	100V
BExDL15E	70V Line	15W	70V
BExDL15E	8 ohm	15W	10.95V
BExDL15E	16 ohm	15W	15.49V

The above table also shows the maximum AC signal voltages at which the loudspeakers can be operated.

The current levels taken by the each loudspeaker will depend on which output tapping has been selected (see section 14 of this instruction manual). BExDL25E 70V and 100V Line units have output levels of 25W, 12.5W, 6W and 2W; BExDL15E 70V and 100V Line units have output levels of 15W, 7.5W, 3W and 1W.

10) Cable Selection

When selecting the cable size consideration must be given to the current that each unit draws, the number of loudspeakers on the line and the length of the cable runs.

SAFETY WARNING: If the loudspeakers are used at high ambient temperatures, i.e. over +40°C, then the cable entry temperature may exceed +70°C and therefore suitable heat resisting cables must be used, with a rated service temperature of at least 110°C.

11) Earthing

All loudspeakers must be connected to a good quality earth. The units are provided with internal and external earthing terminals which are both located on the terminal chamber section of the unit (see figures 2 and 3).

When using the internal earth terminal ensure that the stainless steel M4 flat washer is between the incoming earth wire and the enclosure.

When using the external earth terminal a cable crimp lug must be used. The cable lug should be located between the two M5 stainless steel flat washers. The M5 stainless steel spring

washer must be fixed between the outer flat washer and the M5 stainless steel nut to ensure that the cable lug is secured against loosening and twisting.

The internal earth bonding wires ensure that a good quality earth is maintained between the flameproof chamber casting, the terminal section casting and the terminal cover casting.

12) Cable Glands

The BExDL25E and BExDL15E loudspeakers have dual cable gland entries which have an M20 x 1.5 entry thread as standard. Only cable glands approved for Ex 'e' applications or better (i.e. Ex 'd' applications) can be used. They must be suitable for the type of cable to be used and also meet the requirements of the Ex equipment installation standards EN60079-14:2008 / IEC60070-14:2007.

When only one cable entry is used the other one must be closed with an Ex 'e' blanking plug, which must be suitably approved for the installation requirements.

For combustible dust applications, the cable entry device and blanking elements shall be in type of explosion protection increased safety "e" or flameproof enclosure "d" and shall have an IP 6X rating according to EN60529:1992.

SAFETY WARNING: If the loudspeakers are used at high ambient temperatures, i.e. over +40°C, then the cable entry temperature may exceed +70°C and therefore suitable heat resisting cable glands must be used, with a rated service temperature of at least 110°C.

13) Cable Connections

The cable connections are made into an Ex e II approved twelve way terminal block (six way on low impedance units) which is located in the Increased Safety Area terminal chamber (see figure 3). See section 8 of this manual for access to the terminal chamber. When wiring into Increased Safety Area terminal enclosures, you are only permitted to connect one wire into each way on the terminal block. Therefore in order that loudspeakers can be connected in a parallel line, the terminal block is fitted with approved connecting combs so that each electrical connection has two terminals in parallel. Terminal No's. 1 and 12 (1 and 6 on low impedance units) must not be used on any units. Cables with a cross-sectional area of up to 4mm² can be connected to the terminal block. Cables that have a small cross-sectional area should be fitted with crimp ferules.

The low impedance loudspeakers are fitted with two pairs of terminals 2-3 and 4-5.

The 70V and 100V Line loudspeakers are fitted with five pairs of terminals. Terminals 10-11 which are the common and one of the other four pairs of terminals 8-9, 6 -7, 4-5 or 2-3 should be selected depending on what output level is required (see the following table).

Terminals	BExDL25E (25W) 70V and 100V Line	BExDL15E (15W) 70V and 100V Line
10-11 to 8-9	25W	15W
10-11 to 6-7	12.5W	7.5W
10-11 to 4-5	6W	3W

10-11 to 2-3 2W 1W

14) End of Line DC Monitoring

On BExDL25E and BExDL15E loudspeakers, dc line monitoring can be used if required. Both the 70V and 100V Line units and the Low Impedance units have blocking capacitors fitted. It should be noted that each loudspeaker has a 1M ohm bleed resistor connected across the blocking capacitor and this should be taken into account when selecting the value of the end of line monitoring resistance.

The end of line monitoring resistor can be connected to the end of line unit. **Note the monitoring resistor MUST be connected to the terminals in the flameproof enclosure; it MUST NOT be connected to the terminals in the Increased Safety termination enclosure (see section 7 of this manual for access to the flameproof enclosure).** Figures 4 and 5 show the terminals in the flameproof enclosures for the 70V and 100V Line and low impedance units respectively. On the low impedance units care must be taken with the polarity of the monitoring voltage.

On 70V and 100V line units, the end of line resistor used must have a minimum resistance value of 4k7 ohms and a minimum wattage of 2.5 watts. The terminal numbers, across which the resistor should be fitted, will depend on the output levels selected and are given in the following table:-

Terminals	BExDL25E (25W)	BExDL15E (15W)
A - B	25W	15W
A - C	12.5W	7.5W
A - D	6W	3W
A - E	2W	1W

BExDL25E and BExDL15E 70V and 100V Line Loudspeakers

Flameproof Enclosure

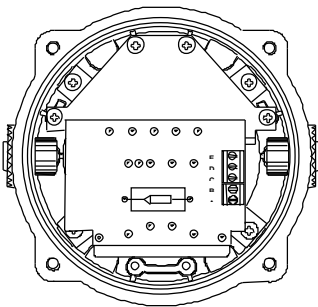

Figure 4

On low impedance units the end of line resistor used must have a minimum resistance value of 2k ohms and a minimum wattage of 0.5 watts or a minimum resistance value of 500 ohms and a minimum wattage of 2 watts. On the low impedance units care must be taken with the polarity of the monitoring voltage. If an end of line resistor is fitted to a unit the links on the printed circuit boards of all loudspeakers in the line must be cut for the dc blocking capacitors to be in circuit in order to dc monitor the line (see figure 5).

BExL25E and BExL15E 8 ohm and 16 ohm Loudspeakers

Flameproof Enclosure

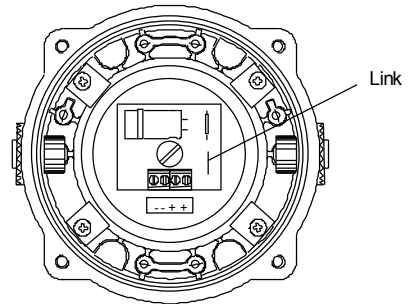

Figure 5

EC DECLARATION OF CONFORMITY



Manufacturer: European Safety Systems Ltd.
Impress House, Mansell Road, Acton
London, W3 7QH, UK

Equipment Type: BExS110D, BExS120D, BExS110E, BExS120E,
BExDS120D, BExDS110D, BExDS120E, BExDS110E,
BExL25D, BExL15D, BExL25E, BExL15E,
BExDL25D, BExDL15D, BExDL25E, BExDL15E,
BExA110D, BExA120D, BExA110E, BExA120E,
BExDA110D, BExDA120D, BExDA110E, BExDA120E,
BExTS110D, BExDTS110D, BExH120D, BExDH120D, BExL25GD, BExDL25GD

Directive 94/9/EC: Electrical and Mechanical equipment for use in explosive atmospheres (ATEX)

Notified Body for EC type Examination: KEMA Quality B.V.
Notified Body No.: 0344
Utrechtseweg 310, 6812 AR Arnhem, The Netherlands

EC-type Examination Certificate: KEMA 99ATEX6312

Notified Body for Quality Assurance Notification: Sira Certification Service
Notified Body No.: 0518
Rake Lane, Eccleston, Chester CH4 9JN, UK

Quality Assurance Notification: SIRA 05 ATEX M342

Provisions fulfilled by the equipment: II 2 G Ex d IIB or IIC T4 or
II 2 G Ex de IIB or IIC T4
II 2 D Ex tD A21 IP66 or IP67 T100 °C or T115 °C

Standards applied: EN 60079-0:2006
EN 60079-1:2007
EN 60079-7:2003
EN 61241-0:2006
EN 61241-1:2004

Directive 89/106/EEC: Construction Products Directive (CPD) – BExS110D24DC / BExS120D24DC (tones 2, 3, 9, 15, 16, 17) only

Notified Body for EC type Examination: VdS Schadensverhütung GmbH
Notified Body No.: 0786
Amsterdamer Str 172-174, 50735 Köln, Germany

EC-type Examination Certificate: 0708-CPD-20225

Standards applied: EN 54-3:2001 + A1:2002

Directive 2009/26/EC: Marine Equipment Directive (MED) – BExS110D24DC-M only

Notified Body for EC type Examination: Germanischer Lloyd SE
Notified Body No.: 0098
Brooktorkai 18, 20457 Hamburg, Germany

EC-type Examination Certificate: 19 702 - 11 HH

Standards applied: EN 54-3:2001 + A1:2002 + A2:2006
IEC 60092-504: 2001
IEC 60533: 1999

Directive 2004/108/EC: Electromagnetic Compatibility Directive (EMC)

Standards applied: EN 61000-6-1:2007
EN 61000-6-2:2005
EN 61000-6-3:2007
EN 61000-6-4:2007

The standards EN 60079-0: 2006, EN 60079-7:2003, EN 61241-0:2006 and EN 61241-1:2004 are no longer harmonized. The requirements of these standards have been checked against the harmonized standards EN 60079-0:2009, EN 60079-7:2007 and EN 60079-31:2009 and there were no major technical changes affecting the latest technical knowledge for the products listed above.

On behalf of European Safety Systems Ltd., I declare that, on the date the equipment accompanied by this declaration is placed on the market, the equipment conforms with all technical and regulatory requirements of the above listed directives.

A handwritten signature in black ink, appearing to read 'Martin Streetz'.

Martin Streetz
Quality Assurance Manager

Telephone: +44 (0)20 8743 8880
Facsimile: +44 (0)20 8740 4200
E-mail: sales@e2s.com
www.e2s.com

Date and Place of Issue: London, 04/07/2012
Document No: DC-001-Issue_C

European Safety Systems Ltd
Company Registration No. 2763350
Registered Office: Impress House
Mansell Road, London, UK, W3 7QH, UK