

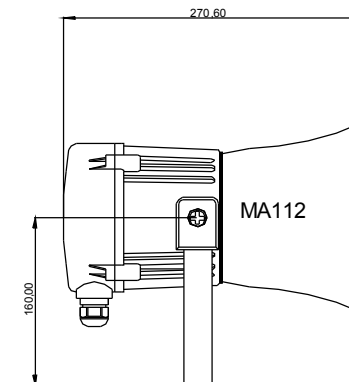

# MA112 - 45 Tone Marine grade IP66 & IP67 Sounder

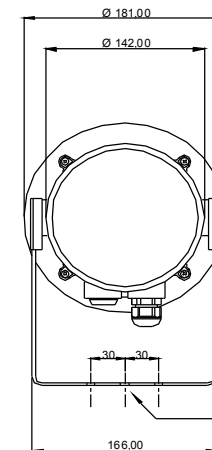

MA112

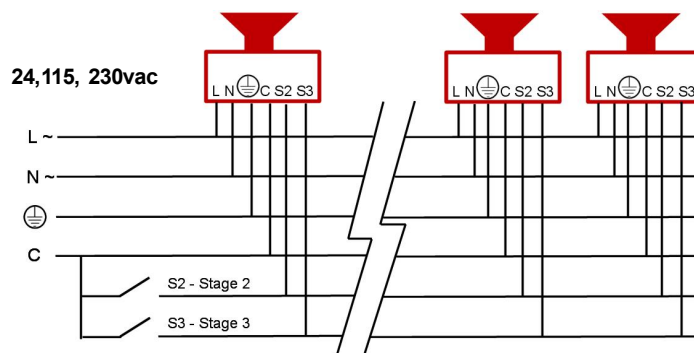
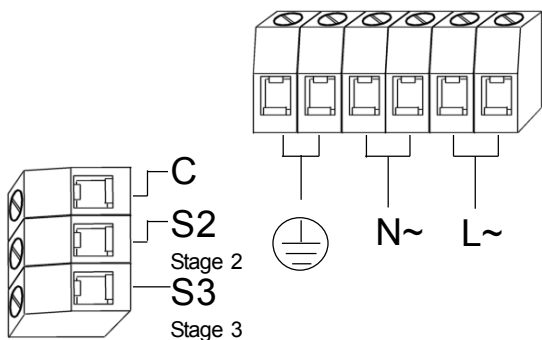
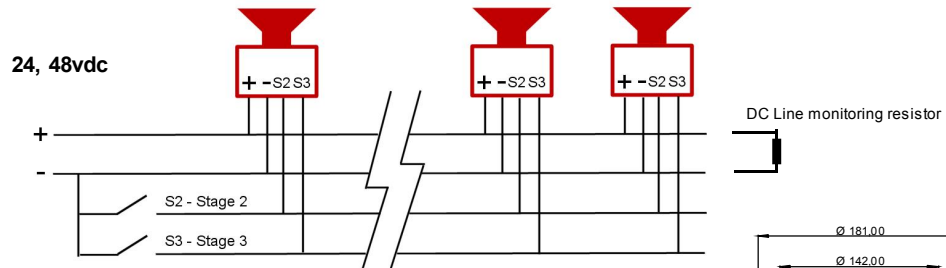
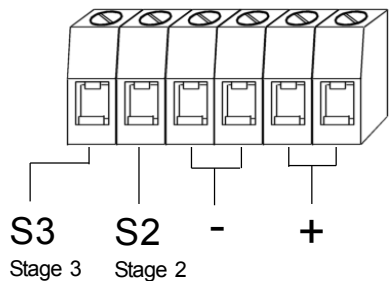

Voltage :	24vdc	48vdc	115vac 50/60Hz	230vac 50/60Hz	24vac 50/60Hz
Voltage range :	10-30vdc	35-60vdc	+/-10%	+/-10%	+/-10%
Current mA :	200mA	120mA	100mA	60mA	500mA



- Volume Control
- Réglage du volume
- Steuerung der Lautstärke
- Controllo volume
- Controlo do Volume
- Control Volumen
- Volumen kontrol
- Volumeregeling
- Volum kontroll
- Volum kontroll



- Tone Selection
- Sélection de la tonalité
- Tonwahl
- Selezione tono
- Seleção de tons
- Selección Tono
- Vælg af tone
- Toonselectie
- Vælg tone
- Tonval

### DC Line monitoring

- Cutlink L1 for line monitoring (DC).
- Couper L1 en cas de contrôle des lignes d'alimentation (c.c.).
- L1 zur Überwachung der Spannungsversorgungsleitungen (Gleichspannung) durchtrennen.
- Interrompere L1 in caso di monitoraggio delle linee dell'alimentatore (CC).
- Corte L1 si está monitorizando las líneas de alimentación eléctrica (CC).
- No caso de monitorização das linhas da alimentação eléctrica (cc), corte L1.
- Afbryd L1, hvis strømforsyningslinjerne overvåges (jævnstrøm).
- Onderbreek L1 wanneer de voedingslijnen (DC) gecontroleerd worden.
- Ta ut L1 dersom strømlinjene overvåkes (DC).
- Bryt L1 vid kontroll av strömkablarna (DC).

Stage 1	Frequency Description	MA112 dB @ 1m	Switch						Stage 2 (S2)	Stage 3 (S3)
			1	2	3	4	5	6		
Tone 1	340 Hz Continuous	107dB(A) @ 1m							Tone 2	Tone 5
Tone 2	800/1000Hz @ 0.25 sec Alternating	112dB(A) @ 1m	■						Tone 17	Tone 5
Tone 3	500/1200Hz @ 0.3Hz 0.5 sec Slow Whoop	113dB(A) @ 1m		■					Tone 2	Tone 5
Tone 4	800/1000Hz @ 1Hz Sweeping	113dB(A) @ 1m		■					Tone 6	Tone 5
Tone 5	2400Hz Continuous	119dB(A) @ 1m			■				Tone 3	Tone 20
Tone 6	2400/2900Hz @ 7Hz Sweeping	116dB(A) @ 1m			■				Tone 7	Tone 5
Tone 7	2400/2900Hz @ 1Hz Sweeping	116dB(A) @ 1m			■				Tone 10	Tone 5
Tone 8	500/1200/500Hz @ 0.3Hz Sweeping	113dB(A) @ 1m		■					Tone 2	Tone 5
Tone 9	1200/500Hz @ 1Hz - DIN / PFEER P.T.A.P.	113dB(A) @ 1m				■			Tone 15	Tone 2
Tone 10	2400/2900Hz @ 2Hz Alternating	119dB(A) @ 1m	■						Tone 7	Tone 5
Tone 11	1000Hz @ 1Hz Intermittent	112dB(A) @ 1m				■			Tone 2	Tone 5
Tone 12	800/1000Hz @ 0.875Hz Alternating	112dB(A) @ 1m	■						Tone 4	Tone 5
Tone 13	2400Hz @ 1Hz Intermittent	119dB(A) @ 1m				■			Tone 15	Tone 5
Tone 14	800Hz 0.25sec on, 1 sec off Intermittent	113dB(A) @ 1m				■			Tone 4	Tone 5
Tone 15	800Hz Continuous	113dB(A) @ 1m				■			Tone 2	Tone 5
Tone 16	660Hz 150mS on, 150mS off Intermittent	109dB(A) @ 1m				■			Tone 18	Tone 5
Tone 17	544Hz (100mS)/440Hz (400mS) - NF S 32-001	109dB(A) @ 1m				■			Tone 2	Tone 27
Tone 18	660Hz 1.8sec on, 1.8sec off Intermittent	109dB(A) @ 1m				■			Tone 2	Tone 5
Tone 19	1.4KHz-1.6KHz 1s, 1.6KHz-1.4KHz 0.5s -NFC48-265	114dB(A) @ 1m				■			Tone 2	Tone 5
Tone 20	660Hz Continuous	109dB(A) @ 1m				■			Tone 2	Tone 5
Tone 21	554Hz/440Hz @ 1Hz Alternating	109dB(A) @ 1m				■			Tone 2	Tone 5
Tone 22	544Hz @ 0.875 sec. Intermittent	109dB(A) @ 1m				■			Tone 2	Tone 5
Tone 23	800Hz @ 2Hz Intermittent	113dB(A) @ 1m				■			Tone 6	Tone 5
Tone 24	800/1000Hz @ 50Hz Sweeping	112dB(A) @ 1m				■			Tone 29	Tone 5
Tone 25	2400/2900Hz @ 50Hz Sweeping	116dB(A) @ 1m				■			Tone 29	Tone 5
Tone 26	Bell	108dB(A) @ 1m	■						Tone 2	Tone 15
Tone 27	554Hz Continuous	109dB(A) @ 1m				■			Tone 26	Tone 5
Tone 28	440Hz Continuous	106dB(A) @ 1m				■			Tone 2	Tone 5
Tone 29	800/1000Hz @ 7Hz Sweeping	112dB(A) @ 1m				■			Tone 7	Tone 5
Tone 30	300Hz Continuous	107dB(A) @ 1m				■			Tone 2	Tone 5
Tone 31	660/1200Hz @ 1Hz Sweeping	112dB(A) @ 1m				■			Tone 26	Tone 5
Tone 32	Two tone chime.	108dB(A) @ 1m				■			Tone 26	Tone 15
Tone 33	745Hz @ 1Hz Intermittent	109dB(A) @ 1m				■			Tone 2	Tone 5
Tone 34	1000 & 2000Hz @ 0.5 sec Alternating - Singapore	114dB(A) @ 1m				■			Tone 38	Tone 45
Tone 35	420Hz @ 0.625 sec Australian Alert	108dB(A) @ 1m				■			Tone 36	Tone 5
Tone 36	500-1200Hz 3.75sec /0.25sec. Australian Evac.	113dB(A) @ 1m				■			Tone 35	Tone 5
Tone 37	1000Hz Continuous - PFEER Toxic Gas	112dB(A) @ 1m				■			Tone 9	Tone 45
Tone 38	2000Hz Continuous	116dB(A) @ 1m				■			Tone 34	Tone 45
Tone 39	800Hz 0.25sec on, 1 sec off Intermittent	113dB(A) @ 1m				■			Tone 23	Tone 17
Tone 40	544Hz (100mS)/440Hz (400mS) - NF S 32-001	112dB(A) @ 1m				■			Tone 31	Tone 27
Tone 41	Motor Siren - slow rise to 1200 Hz	113dB(A) @ 1m				■			Tone 2	Tone 5
Tone 42	Motor Siren - slow rise to 800 Hz	114dB(A) @ 1m				■			Tone 2	Tone 5
Tone 43	1200 Hz Continuous	113dB(A) @ 1m				■			Tone 2	Tone 5
Tone 44	Motor Siren - slow rise to 2400 Hz	118dB(A) @ 1m				■			Tone 2	Tone 5
Tone 45	1KHz 1s on, 1s off Intermittent - PFEER Gen. Alarm	112dB(A) @ 1m				■			Tone 38	Tone 34

NOTE: Please check factory settings and ensure the correct alarm tone is selected for your country or application.  
Pas op: bij ingebruikstelling dient u zich ervan te overtuigen dat de unit op de juiste toon is ingesteld.

>112dB(A)@1m.  
119dB(A) Max.



#### Tone Selection / switch setting.

- Switch settings are shown in the tone table. Black squares are the switch levers in the ON position.
- Les réglages des commutateurs sont indiqués sur le tableau de tonalités. Les carrés noirs représentent les leviers des commutateurs en position MARCHE (ON).
- Die Schaltereinstellungen sind in der Tabelle der Töne angegeben. Die schwarzen Quadrate kennzeichnen die Ein-Positionen der Schalter.
- Le impostazioni degli interruttori sono mostrate nella tabella dei segnali acustici. I riquadri neri indicano le leve degli interruttori nella posizione ON.
- Los ajustes de interruptor se muestran en la tabla de tonos. Los cuadros negros representan las palancas de los interruptores en la posición ON.
- Os ajustes dos interruptores estão indicados na tabela de sons. Os quadrados pretos indicam que as alavancas dos interruptores estão na posição LIGADA.
- Kontaktstillingerne fremgår af toneskemaet. Et sort felt betyder, at kontakten er aktiv ("ON").
- De schakelinstellingen staan vermeld in de toontabel. Zwarte vierkanten zijn de schakelaars in de stand AAN.
- Bryterinnstillinger er beskrevet i tonetabellen. De svarte firkantene indikerer bryterposisjonene i PA-posisjon.
- Brytarinställningarna visas i signaltabellen. De svarta fyrkanterna är brytarna i ON-läge.

- Reverse polarity switching - On DC versions the second stage alarm tone can be selected by reversing the polarity of the supply voltage if wirelink LK1 is present.
- Commutation de polarité inversée. - Dans le cas des appareils c.c., il est possible de sélectionner la tonalité d'alarme de deuxième étage en inversant la tension d'alimentation si la paire de broches LK1 de la carte de circuits imprimés est reliée par un cavalier.
- Schalten durch Polaritätsumkehrung - Bei Gleichspannungsausführungen kann der Alarmton der zweiten Stufe durch Umpolung der Versorgungsspannung gewählt werden, wenn das Stiftpaar LK1 auf der Leiterplatte verbunden ist.
- Commutazione polarità inversa: sulle unità in CC, il segnale acustico di allarme di secondo livello può essere selezionato invertendo la tensione di alimentazione se il connettore con piedini LK1 del circuito è collegato.
- Commutación de polaridad inversa: en unidades de CC el tono de alarma de la segunda fase puede seleccionarse invirtiendo la tensión de alimentación si el par de pines LK1 de la PCB está conectado.
- Comutação de polaridade inversa. - Nas unidades de cc, é possível selecionar o som de alarme da segunda fase invertendo a tensão de alimentação se o suporte de pinos LK1 no circuito impresso estiver ligado.
- Invertering af polaritet. - På jævnstrømsenheder kan alarmtonen for anden fase vælges, ved at man vender spændingen, hvis LK1 på printkortet er aktiveret.
- Omgekeerde polariteitschakeling - op DC-apparaten kan de tweede fase alarmton ges electeerd worden door de toevoerspanning om te keren wanneer de twee PCB-pennen LK1 op de PCB doorverbonden zijn.
- Reversert polaritet. På DC utgaver velges andre trinns alarmtone ved å snu tilførselspenningen hvis hovedpinne LK1 på kretskortet er linket.
- Polaritetsändring. - På DC-enheter kan en andrasteigssignal väljas genom att vända riktning på strömmen om stiftsockeln LK1 på kretskortet är överbygglad.



#### ATTENTION

- Disconnect from power source to prevent electrical shock before installing and servicing
- Couper l'alimentation pour empêcher tout choc électrique avant d'effectuer des travaux d'installation et d'entretien.
- Vor der Installation und Wartung von der Spannungsquelle abnehmen, um elektrische Schläge zu vermeiden.
- Prima dell'installazione e della manutenzione spegnere l'alimentazione elettrica per evitare scosse elettriche.
- Des conecte la alimentación para evitar descargas eléctricas antes de la instalación y mantenimiento
- Antes de instalar ou de fazer a manutenção desligue sempre da alimentação elétrica para evitar choques elétricos.
- Strømmen skal afbrydes ved installering og eftersyn for at undgå elektrisk stød.
- Los koppel van de elektrische voeding om elektrische schok vóór installatie en onderhoud te voorkomen.
- Før monterning eller vedlikehold, må spenningen koples fra for å unngå strømstøt.
- Bryt strömmen innan installation och underhåll för att förhindra elektriska stötter stötar.

ISN3601-A