

# MA112F Alarm Horn Sounder IP66/67

The MA112F is a high output, 119dB(A) alarm sounder. With a robust, fire retardant, IP66 & IP67 Type 4/4X/13 enclosure.

The 'M' series of products have been designed to withstand the harshest of environments. Constructed from lightweight, impact and fire resistant ABS, the range features stainless steel, ratchet adjustable mounting brackets and has been third party tested to IP66/67.

## Features

- Automatic synchronisation on multi-sounder system.
- Continuously rated.
- Large termination area.
- Stainless steel fixings.
- Ratchet adjustable stainless steel 'U' bracket for 360° positioning.
- Duplicate cable terminations (in & out for daisy-chain installations).
- Tropicalisation available on request.
- Available with custom tone configurations and frequencies.
- 'Programmable' version available:
  - 45 alarm tones
  - 4 remotely selectable stages
  - Any tone can be assigned to any stage
  - User configurable continuous frequency tone

## Approvals

- EAC approved.  
Cert: RU D-GB.AL16.V.11083
- Russian Maritime Register of Shipping  
Cert: No. 14.02758.315



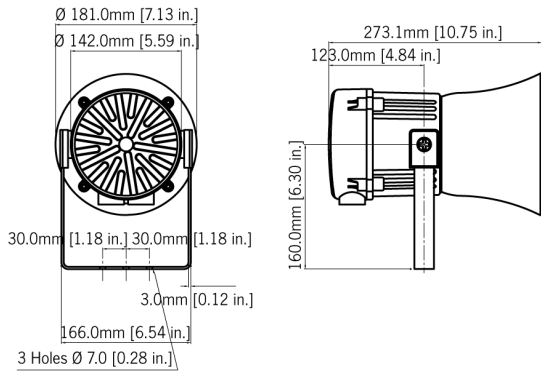

## Specification

Maximum output:	119dB(A) @ 1 metre [110dB(A) @ 10ft/3m]
Nominal output:	112dB(A) @ 1m +/- 3dB - Tone 2 [103dB(A) @ 10ft/3m]
No. of tones:	45 (UKOOA / PFEER compliant)
No. of stages:	3
Volume control:	Max. 112dB(A); Min. 100dB(A) - Tone 2
Effective range:	125m/410ft @ 1KHz
Voltages DC:	24V dc (10-30V dc); 48V dc (35-60V dc) [DC units can use 24V ac for single stage applications.]
Voltages AC:	24V ac; 115V ac; 230V ac
Stage switching:	Negative or positive Reverse polarity stage switching on DC units.
Ingress protection:	IP66 & IP67 (Third party tested)
Housing material:	High impact UL94 V0 & 5VA FR ABS
Colour:	Grey (RAL 7038)
Cable entries:	2 x M20 supplied with 1 blanking plug
Terminals:	0.5 to 4.0mm <sup>2</sup> cables.
Operating temp:	-25 to +55°C [-13° to +131°F]
Storage temp:	-40 to +70°C [-40° to +158°F]
Relative humidity:	90% at 20°C [68°F]
Weight:	DC: 2.50kg/5.5lbs AC:3.00kg/6.6lbs
*SPL data +/-3dB(A). Measured at optimum voltage.	

## Part Codes

Part Code:	Ident.:	Description:
Product type:	MA112	Alarm horn sounder
Flare type:	F	Flare re-entrant horn
Voltage:	AC115 AC230 AC024 DC024 DC048	115V ac 50/60Hz 230V ac 50/60Hz 24V ac 50/60Hz 24V dc (10-30Vdc) 48V dc (42-54V dc)
Cable entries:	A B C	M20x1.5 & ½" NPT M20x1.5 & M20x1.5 ½" NPT & ½" NPT
Stopping plug material:	N	Nylon
Bracket:	1 2	304 (A2) Stainless Steel 316 (A4) Stainless Steel
Approvals:	A1	CE, EAC, RMRS
Enclosure:	R G	Red (RAL 3000) Grey (RAL 7038)

## Alarm Sounder

Version:	Voltage:	Current:
24V dc	10-30V dc	200mA*
48V dc	35-60V dc	120mA*
24V ac 50/60Hz	+/-10%	500mA
115V ac 50/60Hz	+/-10%	100mA
230V ac 50/60Hz	+/-10%	60mA

\* current at nominal voltage on Tone 2

## Tone table

<b>S 1</b>	<b>Description</b>	<b>S 2</b>	<b>S 3</b>	<b>S 1</b>	<b>Description</b>	<b>S 2</b>	<b>S 3</b>
T 1	340 Hz Continuous	T 2	T 5	T 33	745Hz @ 1Hz Intermittent	T 2	T 5
T 2	800/1000Hz @ 0.25 sec Alternating	T 17	T 5	T 34	1000 & 2000Hz @ 0.5 sec Alternating - Singapore	T 38	T 45
T 3	500/1200Hz @ 0.3Hz 0.5 sec Slow Whoop	T 2	T 5	T 35	420Hz @ 0.625 sec Australian Alert	T 36	T 5
T 4	800/1000Hz @ 1Hz Sweeping	T 6	T 5	T 36	500-1200Hz 3.75sec /0.25sec. Australian Evac.	T 35	T 5
T 5	2400Hz Continuous	T 3	T 20	T 37	1000Hz Continuous - PFEER Toxic Gas	T 9	T 45
T 6	2400/2900Hz @ 7Hz Sweeping	T 7	T 5	T 38	2000Hz Continuous	T 34	T 45
T 7	2400/2900Hz @ 1Hz Sweeping	T 10	T 5	T 39	800Hz 0.25sec on, 1 sec off Intermittent	T 23	T 17
T 8	500/1200/500Hz @ 0.3Hz Sweeping	T 2	T 5	T 40	544Hz (100mS)/440Hz (400mS) - NF S 32-001	T 31	T 27
T 9	1200/500Hz @ 1Hz - DIN / PFEER P.T.A.P.	T 15	T 2	T 41	Motor Siren - slow rise to 1200 Hz	T 2	T 5
T 10	2400/2900Hz @ 2Hz Alternating	T 7	T 5	T 42	Motor Siren - slow rise to 800 Hz	T 2	T 5
T 11	1000Hz @ 1Hz Intermittent	T 2	T 5	T 43	1200 Hz Continuous	T 2	T 5
T 12	800/1000Hz @ 0.875Hz Alternating	T 4	T 5	T 44	Motor Siren - slow rise to 2400 Hz	T 2	T 5
T 13	2400Hz @ 1Hz Intermittent	T 15	T 5	T 45	1KHz 1s on, 1s off Intermittent - PFEER Gen. ...	T 38	T 34
T 14	800Hz 0.25sec on, 1 sec off Intermittent	T 4	T 5				
T 15	800Hz Continuous	T 2	T 5				
T 16	660Hz 150mS on, 150mS off Intermittent	T 18	T 5				
T 17	544Hz (100mS)/440Hz (400mS) - NF S 32-001	T 2	T 27				
T 18	660Hz 1.8sec on, 1.8sec off Intermittent	T 2	T 5				
T 19	1.4KHz-1.6KHz 1s, 1.6KHz-1.4KHz 0.5s -NFC48-265	T 2	T 5				
T 20	660Hz Continuous	T 2	T 5				
T 21	554Hz/440Hz @ 1Hz Alternating	T 2	T 5				
T 22	544Hz @ 0.875 sec. Intermittent	T 2	T 5				
T 23	800Hz @ 2Hz Intermittent	T 6	T 5				
T 24	800/1000Hz @ 50Hz Sweeping	T 29	T 5				
T 25	2400/2900Hz @ 50Hz Sweeping	T 29	T 5				
T 26	Bell	T 2	T 15				
T 27	554Hz Continuous	T 26	T 5				
T 28	440Hz Continuous	T 2	T 5				
T 29	800/1000Hz @ 7Hz Sweeping	T 7	T 5				
T 30	300Hz Continuous	T 2	T 5				
T 31	660/1200Hz @ 1Hz Sweeping	T 26	T 5				
T 32	Two T chime.	T 26	T 15				