

A112N Alarm Horn Sounder

The A112N is a high output 120dB(A) automatically synchronised alarm horn sounder. Globally approved for fire, marine and general signalling applications. Featuring 64 alarm tones and 4 remotely activated stages.

Low current consumption and high SPL in a outdoor rated enclosure ensure the A112N is suitable for all applications including fire, security and process control. Designed to withstand the harshest of environments. Constructed from lightweight, impact and fire-resistant ABS, the A112N employs the latest in reliable D Class amplifier technology for superior sound output with low current consumption. The A112N is a member of the versatile AlertAlarm family of industrial alarm horn sounders – also available with Xenon, AL112NX or LED beacons, AL112NH. SIL1 & SIL2 Route 2H compliant to IEC61508 (2010) as standard.

Features

- Automatic synchronisation
- Continuously rated
- Dual M20 or 1/2"NPT clearance cable entries
- Duplicate pluggable cable terminations – Class A
- Ingress protection IP66 Type 4/4X/13/3R
- Conformal coated (tropicalised) electronics
- 64 alarm tone frequencies and 4 remotely activated alarm stages
- Available with custom tone configurations and frequencies
- Diode polarized for use in supervised circuits

Approvals

- UL: UL464
- cUL: CSA C22.2 No 205-17
- ULC: CAN/ULC-S525
- UL EU: (EN54-3) UL-EU-01153-CPR
- CPR 305/2011: 2821-CPR-0108
- MED 2020/1170: MEDB000074G
- DNV GL-CG-0339: TAA00002ZU
- USCG COA 161-002-68-0
- EAC CU TR 043/2017: B.00291/21
- EAC: RU D-GB.GA05.B.12595-20
- RMRS Marine: No. 19.00193.278
- SIL1 & SIL2 compliant to IEC61508 (2010)
- CE, UKCA



Specification

Maximum output:	High power level: 120dB(A) @ 1 m ±3dB [111dB(A) @ 10ft/3m ±3dB] Default power level: 117dB(A) @ 1 m ±3dB [108dB(A) @ 10ft/3m ±3dB]
Nominal output:	High power level: 118dB(A) @ 1m ±3dB [109dB(A) @ 10ft/3m] ±3dB Default power level: 114dB(A) @ 1m ±3dB [105dB(A) @ 10ft/3m ±3dB]
No. of tones:	64 (UK00A / PFEER compliant)
No. of stages:	4
Volume control:	Full range to 0dB(A)
Effective range:	High power level: 214m/702ft @ 1KHz Default power level: 153m/502ft @ 1KHz
Voltages DC:	11.5-54V dc
Voltages AC:	100-240V ac 50/60Hz
In rush:	815mA within 4.0ms @ 24Vdc
Stage switching:	Negative, positive, voltage free
Safety Integrity Level:	SIL1 and SIL2 Route 2H IEC61508 (2010)
Ingress protection:	IP66 Type 4/4X/13/3R
Enclosure:	High impact UL94 V0 & 5VA FR ABS
Terminals:	0.5 - 2.5mm ² (20-14 AWG)
Line monitoring:	Diode polarized for use in supervised circuits
Operating:	-40 to +66°C [-40° to +151°F]
Storage:	-40 to +70°C [-40° to +158°F]
Relative humidity:	99%
Vibration test:	35Hz for a duration 4Hr (UL464)
Jarring test:	3ft/lb Energy (UL464)
Impact test:	3x 5lb (UL464)
MTBF DC:	93.92 years / 822,706 hours - MIL 217
MTBF AC:	46.66 years / 408,508 hours - MIL 217
Weight DC:	1.80kg / 3.96lbs
Weight AC:	2.10kg / 4.62lbs

Part Codes

Variable:	Identifier:	Description:
Product type:	A112N	Alarm horn sounder
Voltage:	DC024 AC230	11.5-54Vdc 100-240Vac 50/60Hz
Back box/cable entries: [e]	A	Back box with mounting lugs - 2 x M20, 1/2"NPT clearance entries
Stopping plug material: [m]	A	ABS
Equip. tag/Duty label: [s]	0 1 2	No equip. tag or Duty label 316 (A4) St/St Equip. tag/Duty label Metalised Polyester Equip. tag/Duty label
Product version: [v]	A	UL/cUL, ULC, CPR, MED, DNV, USCG, RMRS, EAC, CE, UKCA - SIL1 & SIL2
Product option: [o]	1 Z X Y K	Standard product Custom alarm tone software - contact E2S Custom configuration - contact E2S Stage control Config. 4 Stage control Config. 5 (DC) and Config. 2 (AC)
Enclosure colour: [x]	R G	Red Grey

Current Consumption

Product Version:	Nominal Voltage:	Voltage Range:	Default Power Level Current:	High Power Level Current:
DC024	12Vdc	11.5-54V dc	280mA	376mA
	24Vdc		224mA	391mA
	48Vdc		122mA	223mA
AC230	115Vac 50/60Hz	100-240Vac	100mA	173mA
	230Vac 50/60Hz		64mA	107mA

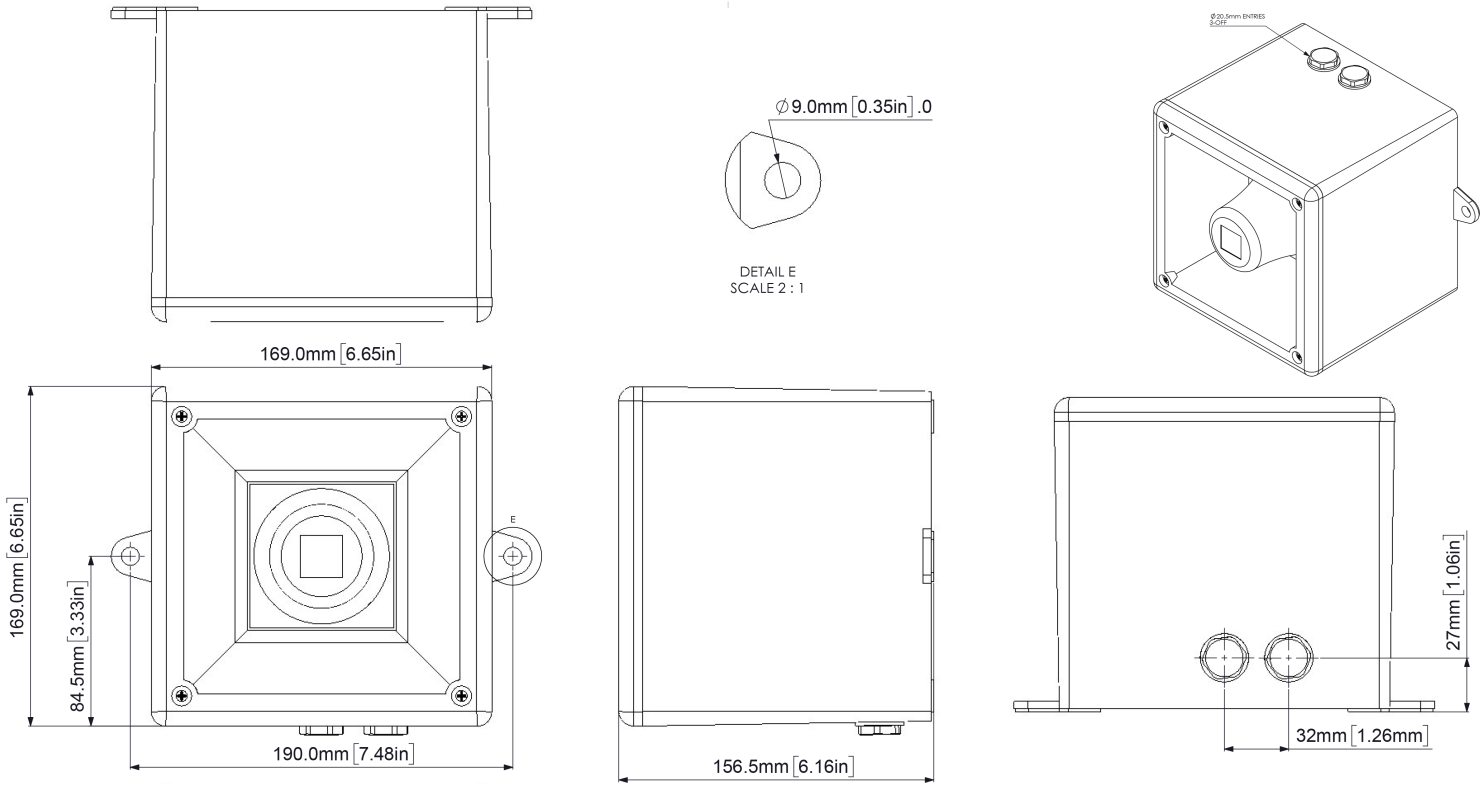

Tone table

S 1	Description	S 2	S 3	S 4
T 1	1000 Continuous - PFEER Toxic Gas	Any	T 2	T 44
T 2	1200/500 @ 1Hz Sweeping - DIN / PFEER P.T.A.P.	Any	T 3	T 44
T 3	1000 @ 0.5Hz (1s on, 1s off) Intermittent - P...	Any	T 2	T 44
T 4	1.4KH-1.6KHz 1s, 1.6KHz-1.4KHz 0.5s - NF C 48...	Any	T 24	T 1
T 5	544(100mS)/440 (400mS) - NF S 32-001	Any	T 19	T 1
T 6	1500/500 - (0.5s on , 0.5s off) x3 + 1s gap - ...	Any	T 44	T 1
T 7	500-1500Hz Sweeping 2 sec on 1 sec off - AS4428	Any	T 44	T 1
T 8	500/1200Hz @ 0.26Hz(3.3s on, 0.5s off) - NEN ...	Any	T 24	T 35
T 9	1000 (1s on, 1s off)x7 + (7s on, 1s off) - IM...	Any	T 34	T 1
T 10	1000 (1s on, 1s off)x7 + (7s on, 1s off) - IM...	Any	T 34	T 1
T 11	420(0.5s on, 0.5s off)x3 + 1s gap - ISO 8201 ...	Any	T 1	T 8
T 12	1000(0.5s on, 0.5s off)x3 + 1s gap - ISO 8201...	Any	T 1	T 8
T 13	422/775 - (0.85 on, 0.5 off) x3 + 1s gap - ...	Any	T 1	T 8
T 14	1000/2000 @ 1Hz - Singapore	Any	T 3	T 35
T 15	300 Continuous	Any	T 24	T 35
T 16	440 Continuous	Any	T 24	T 35
T 17	470 Continuous	Any	T 24	T 35
T 18	500 Continuous - IMO code 2 (Low)	Any	T 24	T 35
T 19	554 Continuous	Any	T 24	T 35
T 20	660 Continuous	Any	T 24	T 35
T 21	800 Continuous - IMO code 2 (High)	Any	T 24	T 35
T 22	1200 Continuous	Any	T 24	T 35
T 23	2000 Continuous	Any	T 3	T 35
T 24	2400 Continuous	Any	T 20	T 35
T 25	440 @ 0.83Hz (0.60s on, 0.60s off) Intermittent	Any	T 44	T 8
T 26	470 @ 0.9Hz (0.55s on, 0.55s off) Intermittent	Any	T 44	T 8
T 27	470 @ 5Hz (0.10s on, 0.10s off) Intermittent	Any	T 44	T 8
T 28	544 @ 1.14Hz (0.43s on, 0.44s off) Intermittent	Any	T 24	T 8
T 29	655 @ 0.875Hz (0.57s on, 0.57s off) Intermittent	Any	T 44	T 8
T 30	660 @ 0.28Hz (1.80s on, 1.80s off) Intermittent	Any	T 24	T 8
T 31	660 @ 3.3Hz (0.15s on, 0.15s off) Intermittent	Any	T 24	T 8
T 32	745 @ 1Hz (0.50s on, 0.50s off) Intermittent	Any	T 24	T 8

S 1	Description	S 2	S 3	S 4
T 33	800 (0.25s on, 1.00s off) Intermittent	Any	T 24	T 8
T 34	800 @ 2Hz (0.25s on, 0.25s off) - IMO code 3...	Any	T 24	T 8
T 35	1000 @ 1Hz (0.50s on, 0.50s off) Intermittent	Any	T 24	T 8
T 36	2400 @ 1Hz (0.50s on, 0.50s off) Intermittent	Any	T 24	T 8
T 37	2900 @ 5Hz (0.10s on, 0.10s off) Intermittent	Any	T 24	T 8
T 38	363/518 @ 1Hz (0.50s / 0.50s) Alternating	Any	T 8	T 19
T 39	450/500 @ 2Hz (0.25s / 0.25s) Alternating	Any	T 8	T 19
T 40	554/440 @ 1Hz (0.50s / 0.50s) Alternating	Any	T 24	T 19
T 41	554/440 @ 0.65Hz (0.76s / 0.76s) Alternating	Any	T 8	T 19
T 42	561/760 @ 0.83Hz (0.60s / 0.60s) Alternating	Any	T 8	T 19
T 43	780/600 @ 0.96Hz (0.52s / 0.52s) Alternating	Any	T 8	T 19
T 44	800/1000 @ 2Hz (0.25s / 0.25s) Alternating	Any	T 24	T 19
T 45	970/800 @ 2Hz (0.25s / 0.25s) Alternating	Any	T 8	T 19
T 46	800/1000 @ 0.875Hz (0.57s / 0.57s) Alternating	Any	T 24	T 19
T 47	2400/2900 @ 2Hz (0.25s / 0.25s) Alternating	Any	T 24	T 19
T 48	500/1200 @ 0.3Hz (1.67s / 1.67s) Sweeping	Any	T 24	T 12
T 49	560/1055 @ 0.18Hz (2.73s / 2.73s) Sweeping	Any	T 24	T 12
T 50	560/1055 @ 3.3Hz (0.15s / 0.15s) Sweeping	Any	T 24	T 12
T 51	600/1250 @ 0.125Hz (4s / 4s) Sweeping	Any	T 24	T 12
T 52	660/1200 @ 1Hz (0.50s / 0.50s) Sweeping	Any	T 24	T 12
T 53	800/1000 @ 1Hz (0.50s / 0.50s) Sweeping	Any	T 24	T 12
T 54	800/1000 @ 7Hz (0.07s / 0.07s) Sweeping	Any	T 24	T 12
T 55	800/1000 @ 50Hz (0.01s / 0.01s) Sweeping	Any	T 24	T 12
T 56	2400/2900 @ 7Hz (0.07s / 0.07s) Sweeping	Any	T 24	T 12
T 57	2400/2900 @ 1Hz (0.50s / 0.50s) Sweeping	Any	T 24	T 12
T 58	2400/2900 @ 50Hz (0.01s / 0.01s) Sweeping	Any	T 24	T 12
T 59	2500/3000 @ 2Hz (0.25s / 0.25s) Sweeping	Any	T 24	T 12
T 60	2500/3000 @ 7.7Hz (0.65s / 0.65s) Sweeping	Any	T 24	T 12
T 61	800Hz Motor Siren	Any	T 24	T 12
T 62	1200Hz Motor Siren	Any	T 24	T 12
T 63	2400Hz Motor Siren	Any	T 24	T 12
T 64	Simulated Bell	Any	T 21	T 12