

ISSUE	MOD No.	INITIAL/DATE
A		INTRODUCTION OF PART GU 28-08-09

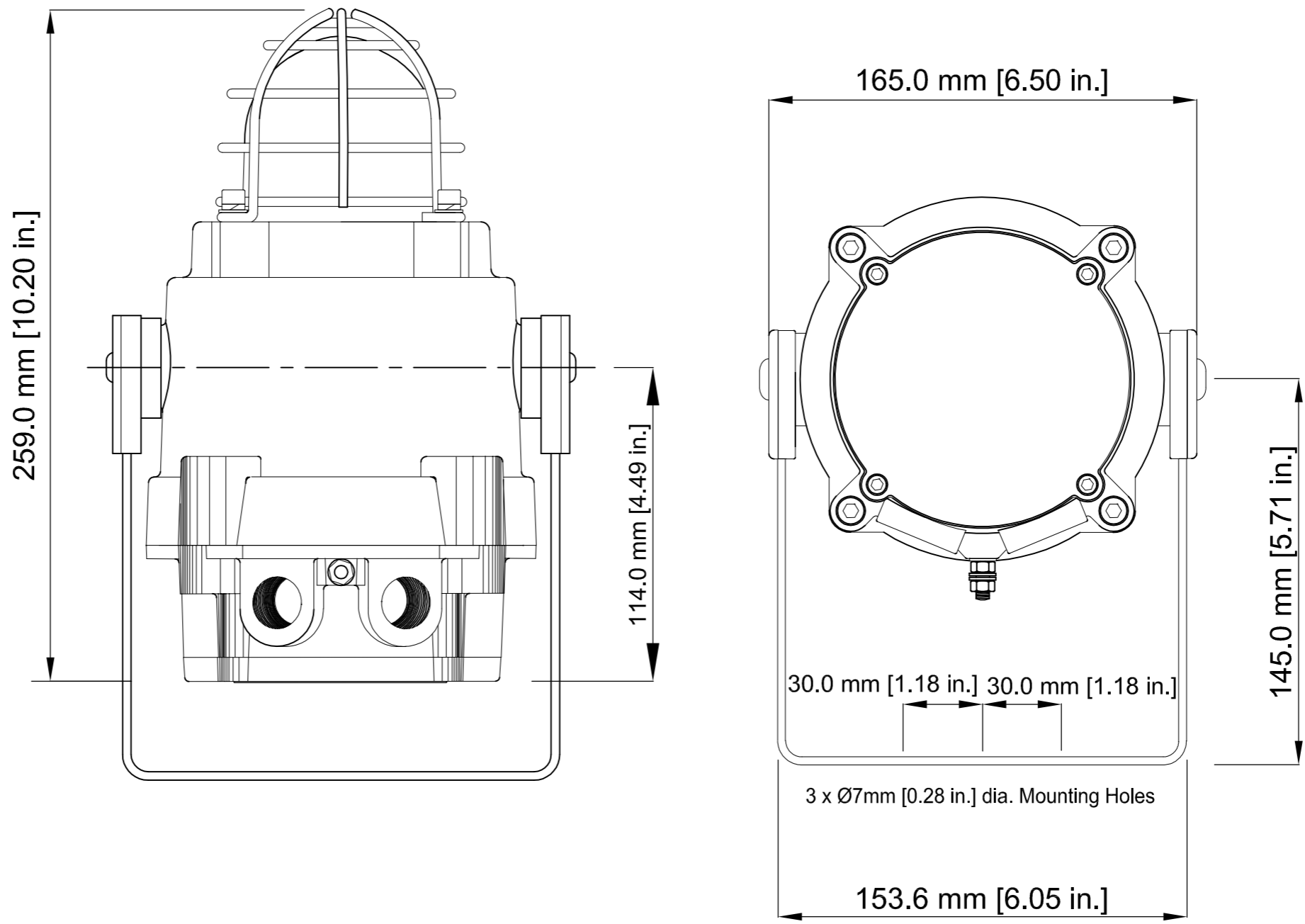

E2S PART NO.	DESCRIPTION	DATA REFERENCE
BExCBG05...	BExCBG05 XENON BEACON (Ex e VERSION)	1.21.110
BExCBG10...	BExCBG10 XENON BEACON (Ex e VERSION)	1.21.120
BExCBG15...	BExCBG15 XENON BEACON (Ex e VERSION)	1.21.130

WHERE APPLICABLE '-UL' VERSIONS ARE COVERED BY THIS OUTLINE DRAWING.

DRAWING TO BS8888:2000 GEOMETRIC TOLERANCES TO ISO1101:1983 LINEAR DIMENSIONAL TOLS ANGULAR DIMENSIONAL TOLS	DRAWN G. UDOWICZENKO	DATE 26-08-09	SURFACE FINISH	WEIGHT (Kg)	THIS DRAWING AND ANY INFORMATION OR DESCRIPTIVE MATTER THEREIN IS COMMUNICATED IN CONFIDENCE AND IS THE COPYRIGHT PROPERTY OF EUROPEAN SAFETY SYSTEMS LTD. NEITHER THE WHOLE OR ANY EXTRACT MAY BE DISCLOSED, LOANED, COPIED OR USED FOR MANUFACTURING OR TENDERING PURPOSES WITHOUT THEIR WRITTEN CONSENT. EUROPEAN SAFETY SYSTEMS LTD. AS PER LATEST DATE OF ISSUE SHOWN ABOVE	 warning signals EUROPEAN SAFETY SYSTEMS LTD IMPRESS HOUSE MANSELL ROAD ACTON LONDON W3 7QH WWW.E2S.COM	ALL DIMENSIONS IN MM IF IN DOUBT, ASK - DO NOT SCALE		A2
	CHECKED	DATE	MATERIAL				TITLE BExBG Ex e BEACON OUTLINE		
	APPROVED	DATE	ALTERNATIVE MATERIAL				SCALE NTS	SHEET 1 OF 1	DRAWING NUMBER SK0119