

# DC CONFIGURATIONS

**E2S PART NO**  
D1x[C3][J2][XX][XX][XX][XXX]

**DESCRIPTION**  
D1xC3 STACK - 3 BEACONS & ALARM HORN  
WITH JUNCTION BOX

**DATA REFERENCE**  
1-26-080

Note: Alternative wiring configurations may be available on request - contact E2S sales

ISSUE	MOD No.	REASON - INITIAL - DATE
2		-VE / N COMMON TERMINAL MOVED TO T5 - DAH - 26-02-2020
3		DC WAS -VE STAGE SWITCHING NOW +VE. SOUNDER TNALS UPDATED TO NEW PCBA. DAH - 22-09-2021
4		DIAGRAMS CONFIG 1 - 6 CREATED

## CONFIG. 1 (DEFAULT)

DC VOLTAGE SUPPLY  
COMMON NEGATIVE CONNECTION TO ALL SIGNALS  
POSITIVE STAGE SWITCHING FOR ALARM HORN SOUNDER

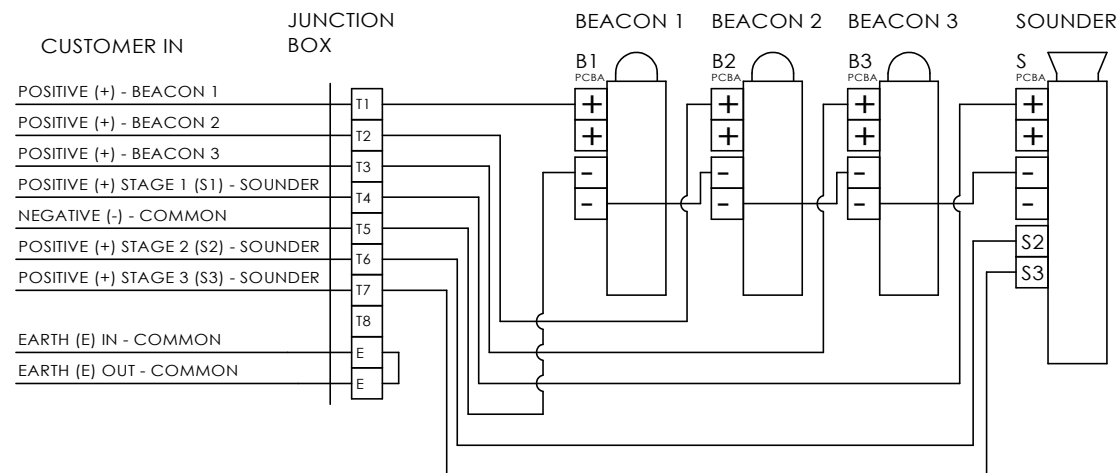

## CONFIG. 3

DC VOLTAGE SUPPLY  
COMMON NEGATIVE CONNECTION TO ALL SIGNALS  
NEGATIVE STAGE SWITCHING FOR ALARM HORN SOUNDER

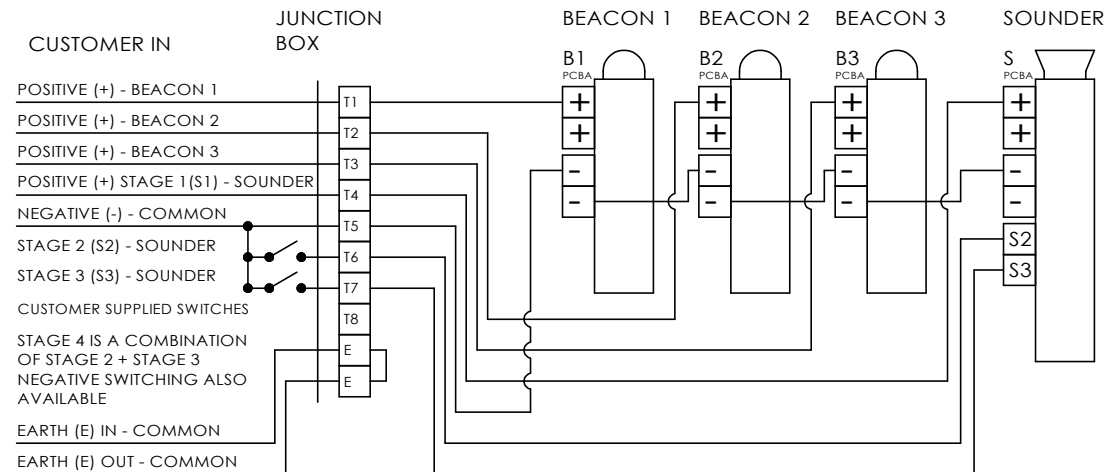

## CONFIG. 2

DC VOLTAGE SUPPLY  
INDEPENDENT CONNECTIONS TO ALL SIGNALS  
POSITIVE STAGE SWITCHING FOR ALARM HORN SOUNDER

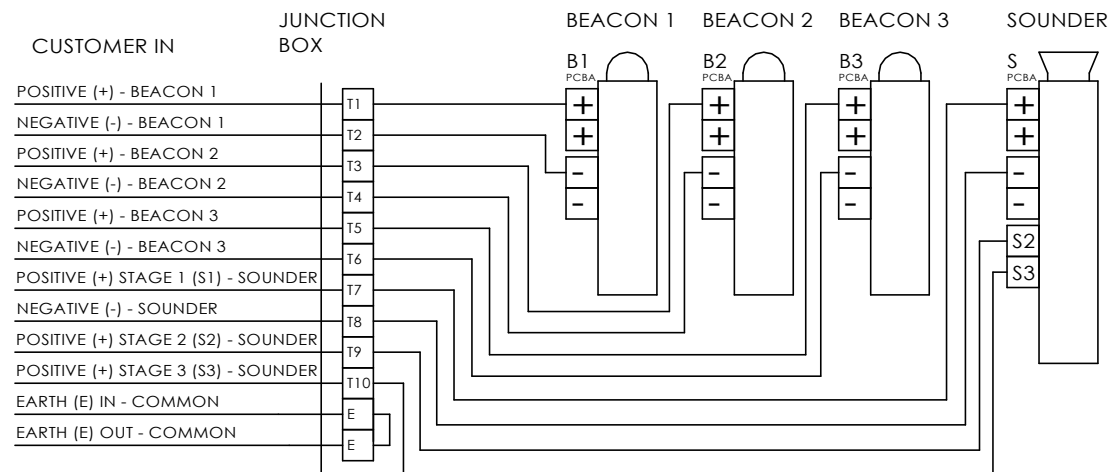

## CONFIG. 4

DC VOLTAGE SUPPLY  
INDEPENDENT CONNECTIONS TO ALL SIGNALS  
NEGATIVE STAGE SWITCHING FOR ALARM HORN SOUNDER

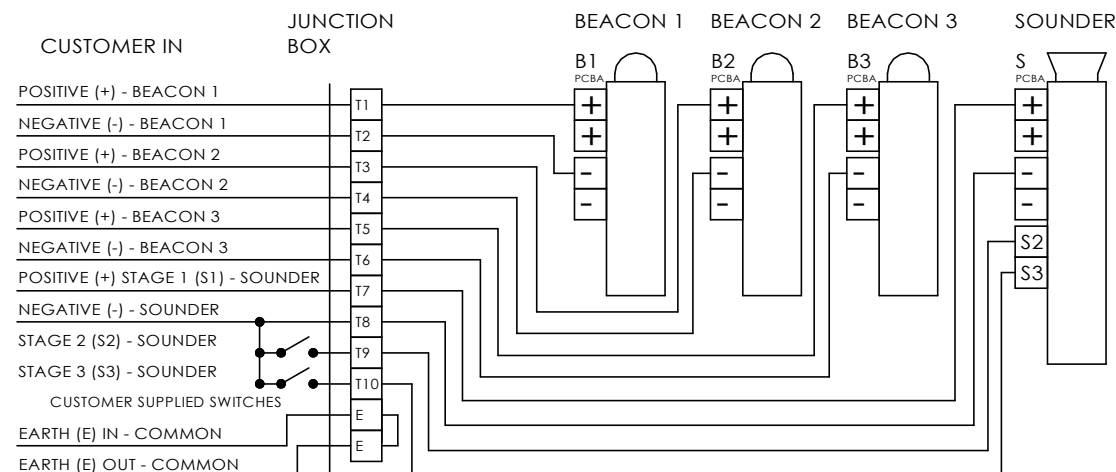

DRAWING TO BS8888:2000  
GEOMETRIC TOLERANCES TO ISO1101:1983  
LINEAR DIMENSIONAL TOLS  
ANGULAR DIMENSIONAL TOLS

DRAWN	DATE
D.HOWGILL	15-08-2019
CHECKED	DATE
R.N.POTTS	15-08-2019
APPROVED	DATE
R.N.POTTS	15-08-2019

SURFACE FINISH	WEIGHT (Kg)
FINISH	
MATERIAL	
ALTERNATIVE MATERIAL	

THIS DRAWING AND ANY INFORMATION OR DESCRIPTIVE MATTER THEREIN IS COMMUNICATED IN CONFIDENCE AND IS THE COPYRIGHT PROPERTY OF EUROPEAN SAFETY SYSTEMS LTD. NEITHER THE WHOLE OR ANY EXTRACT MAY BE DISCLOSED, LOANED, COPIED OR USED FOR MANUFACTURING OR TENDERING PURPOSES WITHOUT THEIR WRITTEN CONSENT.

EUROPEAN SAFETY SYSTEMS LTD.  
AS PER LATEST DATE OF ISSUE SHOWN ABOVE

**e2s**  
warning signals  
EUROPEAN SAFETY SYSTEMS LTD  
IMPRESS HOUSE  
MANSELL ROAD  
ACTON  
LONDON W3 7QH  
WWW.E2S.COM

ALL DIMENSIONS IN MM  
IF IN DOUBT, ASK -  
DO NOT SCALE

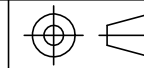

**A2**

TITLE D1xC3 STACK - 3 BEACONS & ALARM HORN  
WITH JUNCTION BOX WIRING SCHEMATIC

SCALE	SHEET	DRAWING NUMBER
NTS	1 OF 3	D226-06-148

# DC CONFIGURATIONS

ISSUE	MOD No.	REASON - INITIAL - DATE
2		SEE SH1
3		SEE SH1
4		SEE SH1

## CONFIG. 5

DC VOLTAGE SUPPLY  
 BEACON 1 / STAGE 1 LINKED ; BEACON 2 / STAGE 2 LINKED ; BEACON 3 / STAGE 3 LINKED  
 INDEPENDENT STAGE WIRING FOR ALARM HORN SOUNDER WITH END OF LINE MONITORING (3 STAGES)

## ENTRY TERMINALS

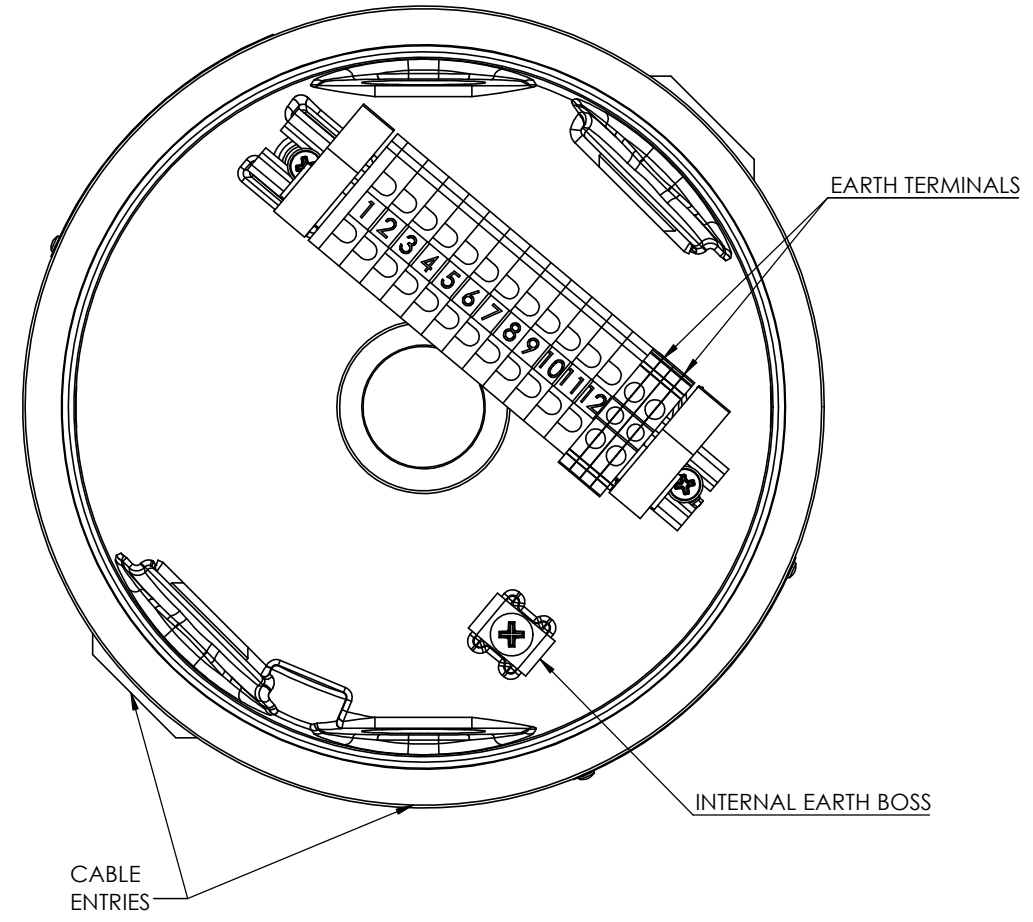
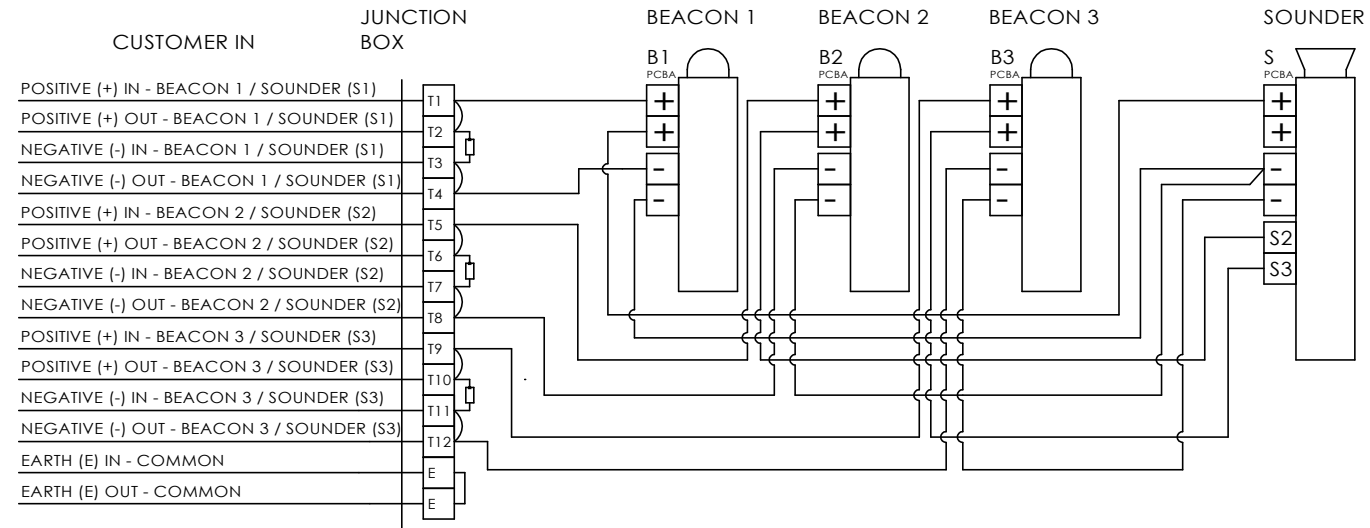

## CONFIG. 6

DC VOLTAGE SUPPLY  
 INDEPENDENT CONNECTIONS TO ALL SIGNALS  
 INDEPENDENT STAGE WIRING FOR ALARM HORN SOUNDER WITH END OF LINE MONITORING (3 STAGES)

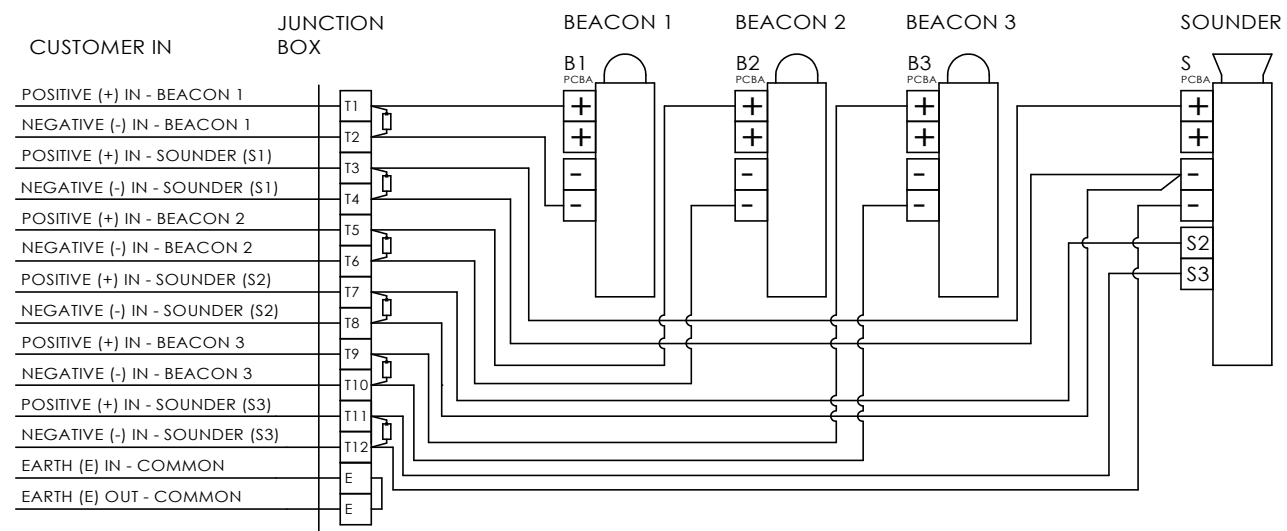

DRAWING TO BS8888:2000 GEOMETRIC TOLERANCES TO ISO1101:1983 LINEAR DIMENSIONAL TOLS ANGULAR DIMENSIONAL TOLS	DRAWN D.HOWGILL	DATE 15-08-2019	SURFACE FINISH FINISH	WEIGHT (kg)	THIS DRAWING AND ANY INFORMATION OR DESCRIPTIVE MATTER THEREIN IS COMMUNICATED IN CONFIDENCE AND IS THE COPYRIGHT PROPERTY OF EUROPEAN SAFETY SYSTEMS LTD. NEITHER THE WHOLE OR ANY EXTRACT MAY BE DISCLOSED, LOANED, COPIED OR USED FOR MANUFACTURING OR TENDERING PURPOSES WITHOUT THEIR WRITTEN CONSENT.	 EUROPEAN SAFETY SYSTEMS LTD IMPRESS HOUSE MANSELL ROAD ACTON LONDON W3 7QH WWW.E2S.COM	ALL DIMENSIONS IN MM IF IN DOUBT, ASK - DO NOT SCALE	 A2
	CHECKED R.N.POTTS	DATE 15-08-2019	MATERIAL	TITLE D1xC3 STACK - 3 BEACONS & ALARM HORN WITH JUNCTION BOX WIRING SCHEMATIC				
	APPROVED R.N.POTTS	DATE 15-08-2019	ALTERNATIVE MATERIAL	SCALE NTS			SHEET 2 OF 3	

# AC CONFIGURATIONS

ISSUE	MOD No.	REASON - INITIAL - DATE
2		SEE SH1
3		SEE SH1
4		SEE SH1

## CONFIG. 1 (DEFAULT)

- AC VOLTAGE SUPPLY
- COMMON NEUTRAL CONNECTION TO ALL SIGNALS
- COMMON STAGE SWITCHING FOR ALARM HORN SOUNDER

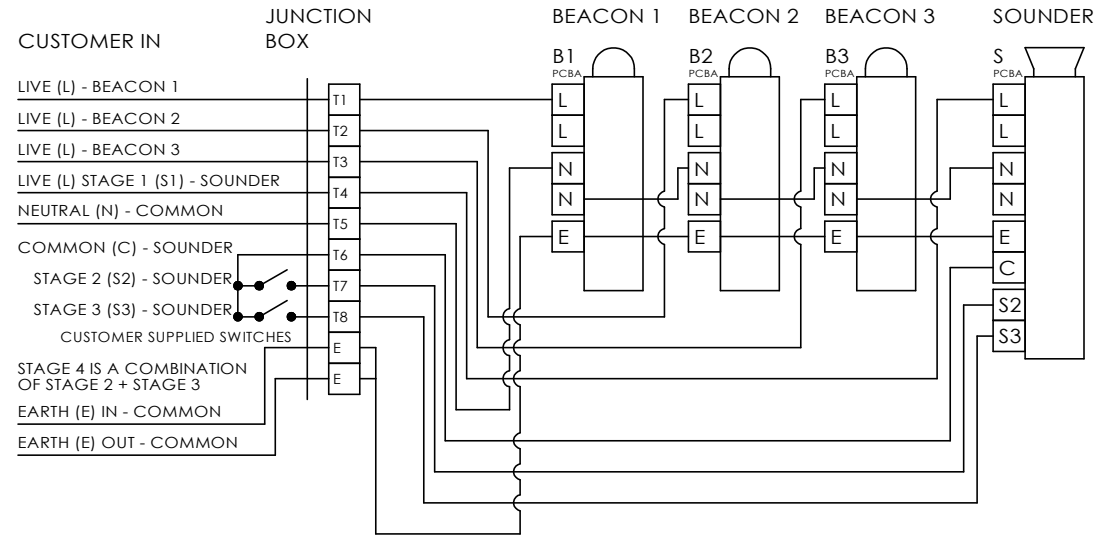

## CONFIG. 2

- AC VOLTAGE SUPPLY
- INDEPENDENT CONNECTIONS TO ALL SIGNALS
- COMMON STAGE SWITCHING FOR ALARM HORN SOUNDER

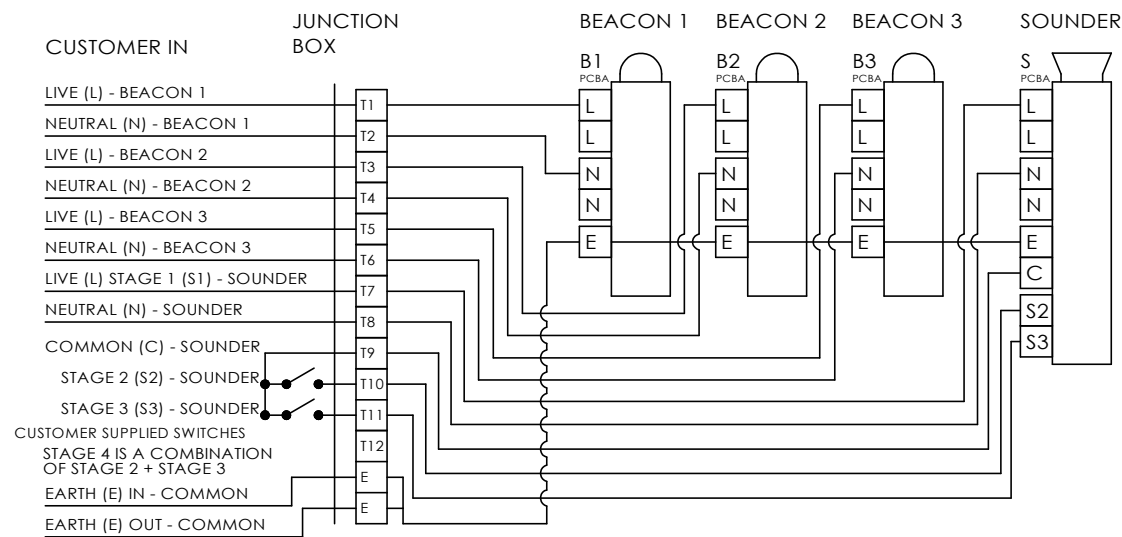

DRAWING TO BS8888:2000 GEOMETRIC TOLERANCES TO ISO1101:1983 LINEAR DIMENSIONAL TOLS ANGULAR DIMENSIONAL TOLS	DRAWN D.HOWGILL	DATE 15-08-2019	SURFACE FINISH FINISH	WEIGHT (kg)	THIS DRAWING AND ANY INFORMATION OR DESCRIPTIVE MATTER THEREIN IS COMMUNICATED IN CONFIDENCE AND IS THE COPYRIGHT PROPERTY OF EUROPEAN SAFETY SYSTEMS LTD. NEITHER THE WHOLE OR ANY EXTRACT MAY BE DISCLOSED, LOANED, COPIED OR USED FOR MANUFACTURING OR TENDERING PURPOSES WITHOUT THEIR WRITTEN CONSENT.	 EUROPEAN SAFETY SYSTEMS LTD IMPRESS HOUSE MANSELL ROAD ACTON LONDON W3 7QH WWW.E2S.COM	ALL DIMENSIONS IN MM IF IN DOUBT, ASK - DO NOT SCALE		A2
	CHECKED R.N.POTTS	DATE 15-08-2019					TITLE D1xC3 STACK - 3 BEACONS & ALARM HORN WITH JUNCTION BOX WIRING SCHEMATIC		
	APPROVED R.N.POTTS	DATE 15-08-2019					ALTERNATIVE MATERIAL		

© EUROPEAN SAFETY SYSTEMS LTD.  
AS PER LATEST DATE OF ISSUE SHOWN ABOVE