

# INSTRUCTION MANUAL

## D2xP1 Status Light

### 2 Beacons with Junction Box

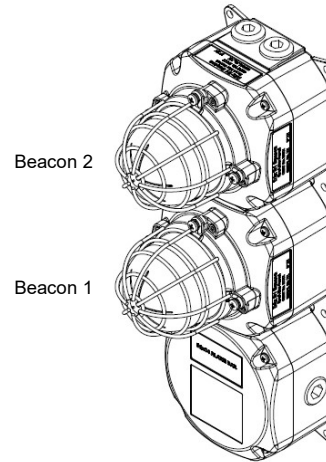
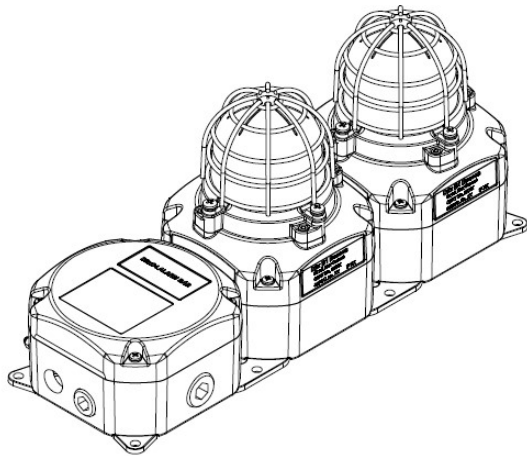

### 1) Warnings

Please see individual product instruction manual. See Table 1 for Instruction Manual Document Number.

### 2) Rating & Marking Information

Please see individual product instruction manual. See Table 1 for Instruction Manual Document Number.

All individual unit ratings must be suitable for the installation.

### 3) Type Approval Standards

Please see individual product instruction manual. See Table 1 for Instruction Manual Document Number.

### 4) Installation Requirements

Please see individual product instruction manual. See Table 1 for Instruction Manual Document Number.

### 5) Special Conditions of Use

Please see individual product instruction manual. See Table 1 for Instruction Manual Document Number.

### 6) Part Coding

Part Code:	Identifier - Description
Product Type	D2xP1
Junction Box	J1 = Junction Box / Standard J2 = Junction Box / With mounting plate
Beacon Type (Add Code for each Beacon in Status Light)	1Y = D2xB1X05 2Y = D2xB1X10 5Y = D2xB1LD2 Where Y = Lens Colour, choose from: A = Amber, B = Blue, C = Clear, G = Green, M = Magenta, R = Red, Y = Yellow
Voltage	DC024 = 24Vdc DC048 = 48Vdc AC115 = 115-120Vac 50/60Hz AC230 = 220-230Vac 50/60Hz
Cable Entries [e]	A = 2 x M20 B = 2 x 1/2" NPT + 2 x 3/4" NPT C = 2 x 3/4" NPT (Adaptors) + 2 x 3/4" NPT D = 2 x M25 (Adaptors)
Stopping Plug / Adaptor Material [m]	B = Brass N = Nickel Plated S = Stainless Steel
Guard / Tag Material [s]	1 = 316 St.Steel Guard & 316 Tag 3 = 316 St.Steel Guard, 316 Tag & Duty Labels 3 = 316 St.Steel Guard, 316 Tag & Duty Labels attached by steel wire
Product Version [v]	A = ATEX / IECEx / UL / cUL
Product Option [o]	1 = Standard Wiring 2 = Independent Wiring W = Special Wiring X = Special Configuration
Assembly Colour [x]	R = Red, G = Grey Other colours also possible, contact E2S sales

Component Part Code Ref.	Component Description	Document Number
D2xB1X05	5J Xenon Beacon	D211-00-201-IS
D2xB1X10	10J Xenon Beacon	D211-00-201-IS
D2xB1LD2	Multifunction LED Beacon	D211-00-401-IS
D2xJ1	Junction Box	D211-00-501-IS

Table 1: Product Instruction Manual Reference

## 7) Location and Mounting

The location of the Status Light should be made with due regard to the area over which the warning signal must be visible/audible. They should only be fixed to services that can carry the weight of the unit.

The D2xP1J1 Status Light should be secured to any flat surface using eight 7mm fixing holes in the feet of the Status Light. See figure 1.

The plated Status Light D2xP1J2 should be secured to any flat surface using eight 7mm fixing holes in the plate. See figure 1c

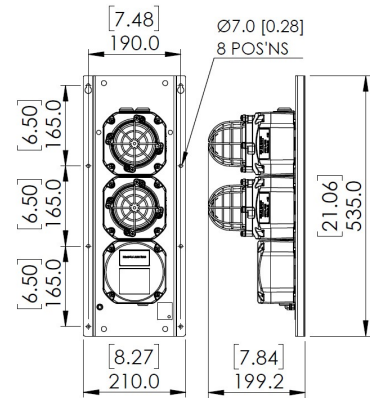

Fig. 1c: Fixing Location for plated Status Light

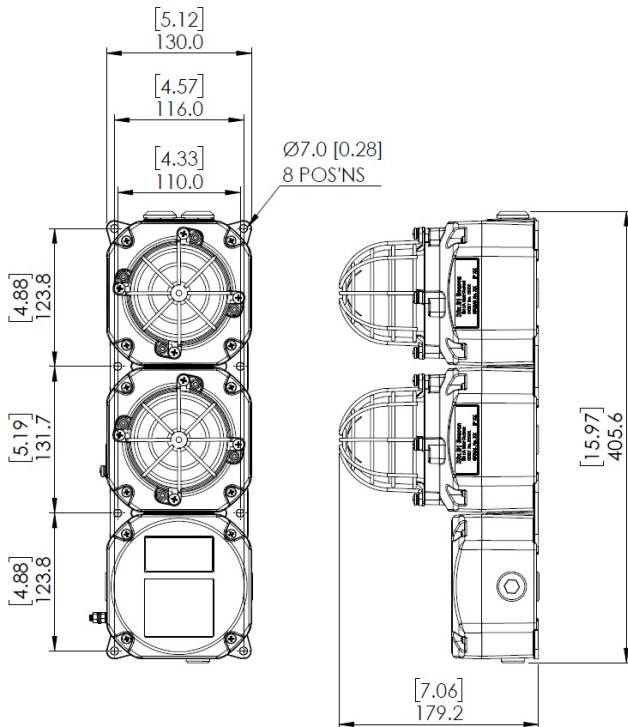

Fig. 1a: Fixing Location for P1 Status Light

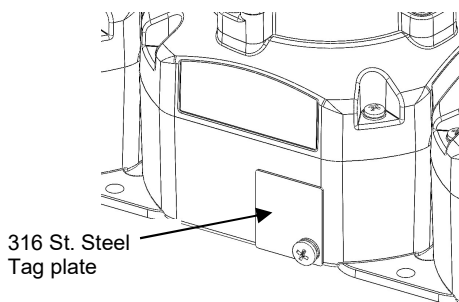

Fig. 1b: Equipment Tag Location

## 8) Access to the Enclosure



Warning – High voltage may be present, risk of electric shock. DO NOT open when energised, disconnect power before opening.



Warning – Hot surfaces. External surfaces and internal components may be hot after operation, take care when handling the equipment.

To connect the electrical supply cables to the beacon it is necessary to remove the cover to gain access to the chamber. To access the chamber, loosen the four M4 posi-pan head screws and withdraw the cover. (See figure 2).

To replace cover, check that the 'O' ring seal is in place. Carefully push the cover in place. Insert and tighten down M4 screws and fibre washers.

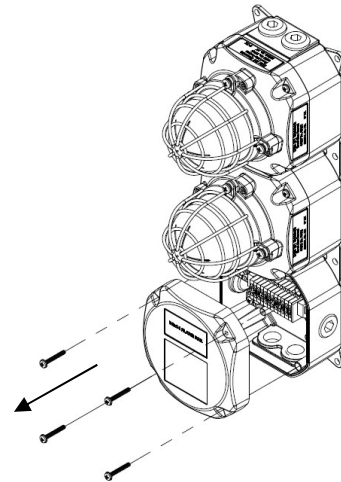

Fig. 2: Accessing the Junction Box Terminals

## 9) Power Supply Selection

For Voltage ranges of complete units, take the highest Minimum value and lowest Maximum value in the ranges of the component units. For Current and Max Current ratings of complete units, add the ratings from the component units:

Please see individual product instruction manual for Voltage Range, Current and Max Current values.

For E.g. D2X[P1][J1][1G][1A][AC115]:

Unit Type	D2xJ1	D2xB1X05	D2xB1X05	<b>D2XP1 Total</b>
Voltage Range	230Vac 60Hz max.	115- 120Vac 50/60Hz	115- 120Vac 50/60Hz	<b>115-120Vac 50/60Hz</b>
Current	N/A	80mA	80mA	<b>160mA</b>
Max Current	N/A	80mA	80mA	<b>160mA</b>

## 10) Selection of Cable, Cable Glands, Blanking Elements & Adapters

Please see individual product instruction manual.

The D2xP1 Status Light can be supplied with the following types of adapters:

M20 to M25  
1/2" NPT to 3/4" NPT

NOTE: Stopping plugs cannot be fitted into adapters.

## 11) Earthing

The Status Light is provided with an M5 earth stud on the first unit. Earthing connections should be made to the M5 earth stud, using a ring crimp terminal to secure the earth conductor to the earth stud.

If the optional mounting plate is selected, an M6 earth post is located by the entry unit on the plate.

Please see individual product instruction manual for details of earthing each beacon

## 12) Cable Connections

Electrical connections are to be made into the junction box. See section 8 of this manual for access to the enclosure. See also figure 3 for DC and AC DIN rail terminal entry detail.

Wires having a cross sectional area between 0.5 mm<sup>2</sup> to 2.5mm<sup>2</sup> can be connected to each terminal way. Strip wires to 8mm. Wires may also be fitted using ferrules. Terminal screws need to be tightened down with a tightening torque of 0.45 Nm / 5 Lb-in. When connecting wires to the terminals great care should be taken to dress the wires so that when the cover is inserted into the chamber the wires do not exert excess pressure on the terminal blocks. This is particularly important when using cables with large cross-sectional areas such as 2.5mm<sup>2</sup>.

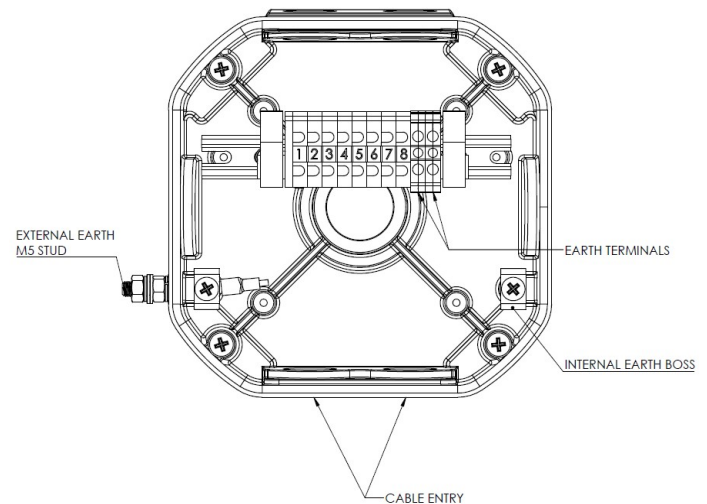

Fig. 3: Junction Box Internals

## 13) Wiring

See table 2 for summary of wiring diagrams  
See schematic document D215-06-132

### Note:

For units with product codes where Product Option = X or W, please see special wiring schematic supplied with the unit documentation.

## 14) Interchangeable & Spare Parts

The Beacon lens cover is interchangeable, contact E2S Ltd for a replacement lens cover available in various colours.

To change the lens cover, unscrew the 4-off M5 posi pan head screws, spring and flat washers using a screwdriver. Remove the wire guard and replace the old lens cover with the new lens cover.

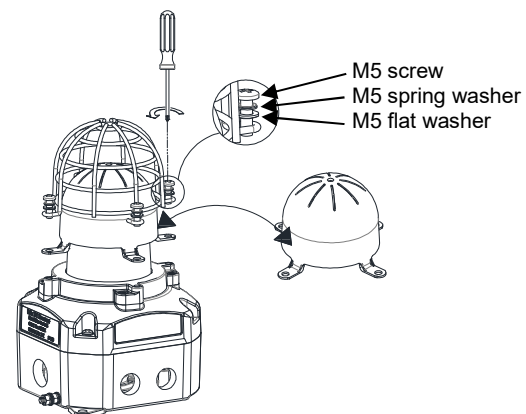

Fig. 6: Replacement of beacon lens cover

To reassemble optional duty label, see figure 7.

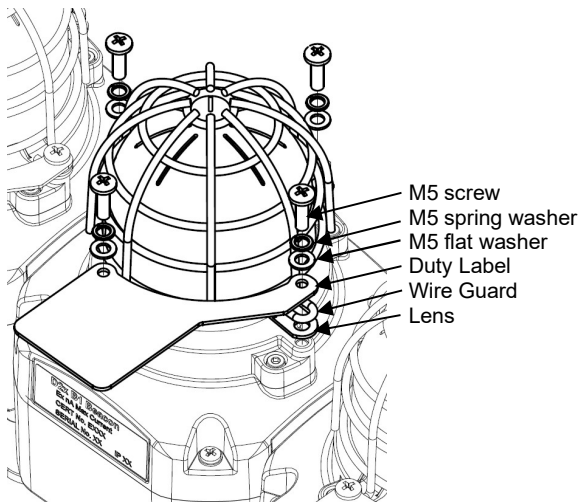

Fig. 7: Assembly of Duty Label

## 15) Maintenance, Overhaul and Repair

Please see individual product instruction manual. See Table 1 for Instruction Manual Document Number.

DC DIAGRAMS				
Config.	Voltage	Configuration Description	Features	Product Option [o]
1	DC	Standard wiring	<ul style="list-style-type: none"> <li>Common negative connection to all signals</li> </ul>	1
2	DC	Independent wiring	<ul style="list-style-type: none"> <li>Independent wiring to all signals</li> </ul>	2
AC DIAGRAMS				
Config.	Voltage	Configuration Description	Features	Product Option [o]
1	AC	Standard wiring (Default)	<ul style="list-style-type: none"> <li>Common neutral connection to all signals</li> </ul>	1
2	AC	Independent wiring	<ul style="list-style-type: none"> <li>Independent wiring to all signals</li> </ul>	2

Table 2 – Summary of Wiring Configurations

# DC CONFIGURATIONS

**E2S PART NO**  
**D2x[P1][J1][XX][XX]**  
**D2x[P1][J2][XX][XX]**

**DESCRIPTION**  
**D2xP1 STACK - 2 BEACONS WITH JUNCTION BOX**

**DATA REFERENCE**  
**1-35-010**

Note: Alternative wiring configurations may be available on request - contact E2S sales

ISSUE	MOD No.	REASON - INITIAL - DATE
1		INTRODUCTION DAH - 15-08-2019
2		-VE / N COMMON MOVED TO T3 DAH - 21-02-2020
3		CONFIG 1-2 ADDED. SH2 ADDED DAH - 20/04/2023

## CONFIG. 1 (DEFAULT)

DC VOLTAGE SUPPLY  
 COMMON NEGATIVE CONNECTION TO ALL SIGNALS

## ENTRY TERMINALS

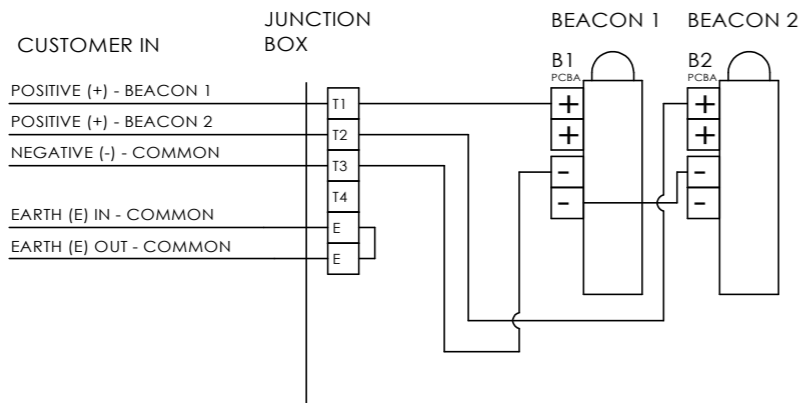

## CONFIG. 2

DC VOLTAGE SUPPLY  
 INDEPENDENT CONNECTIONS TO ALL SIGNALS

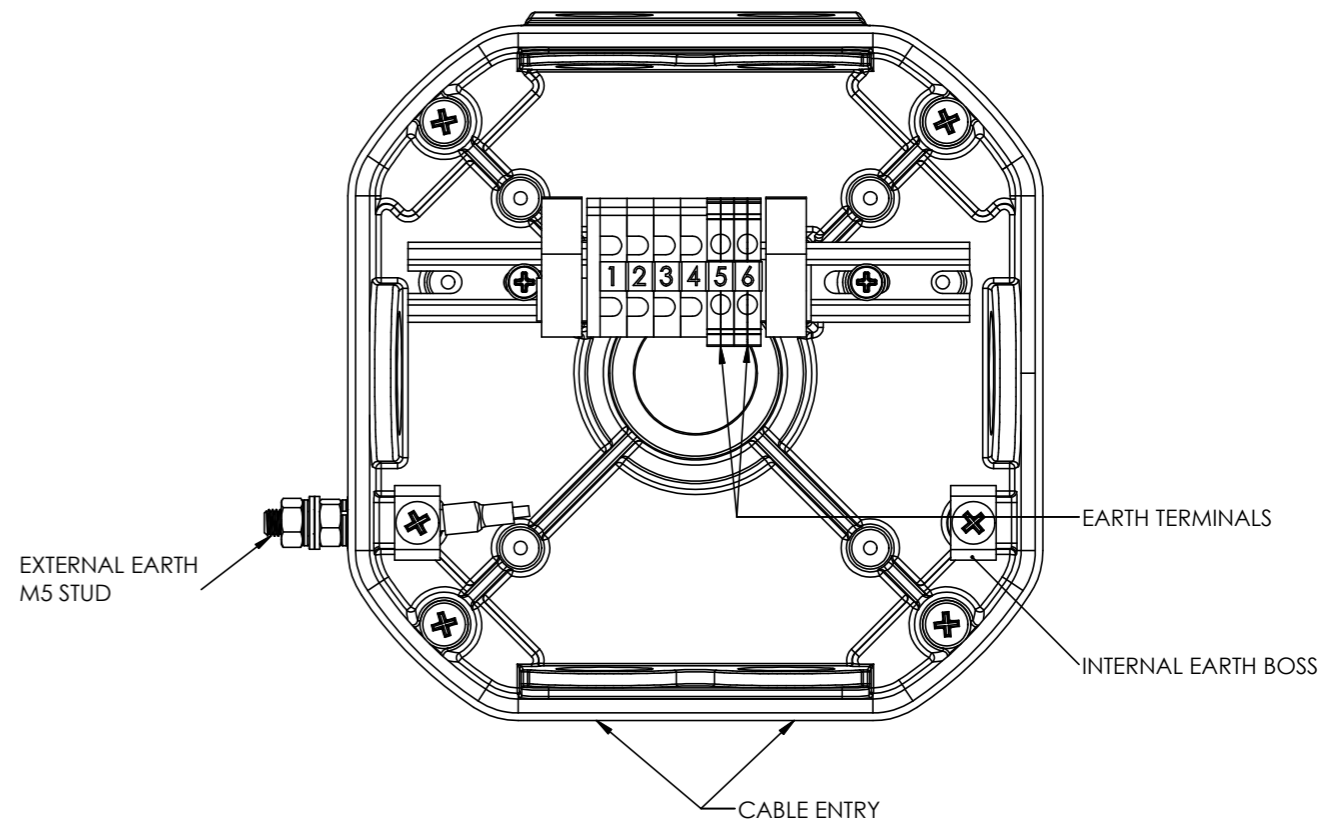
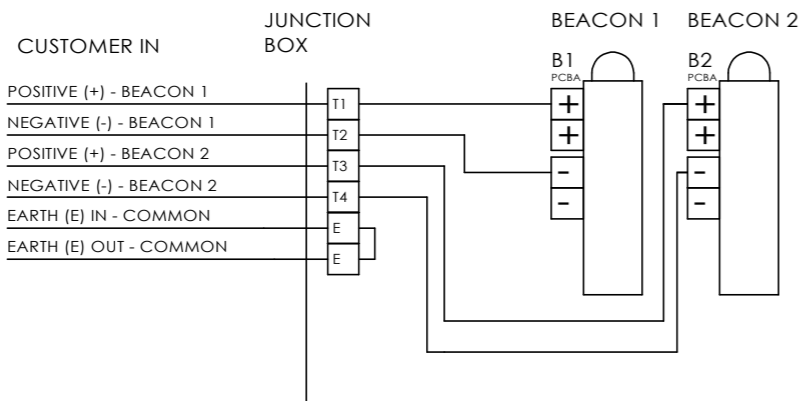

DRAWING TO BS8888:2000  
 GEOMETRIC TOLERANCES TO ISO1101:1983  
 LINEAR DIMENSIONAL TOLS  
 ANGULAR DIMENSIONAL TOLS

<b>DRAWN</b>	<b>DATE</b>
D.HOWGILL	15-08-2019
<b>CHECKED</b>	<b>DATE</b>
R.N.POTTS	15-08-2019
<b>APPROVED</b>	<b>DATE</b>
R.N.POTTS	15-08-2019

<b>SURFACE FINISH</b>	<b>WEIGHT (kg)</b>
<b>FINISH</b>	
<b>MATERIAL</b>	
<b>ALTERNATIVE MATERIAL</b>	

THIS DRAWING AND ANY INFORMATION OR DESCRIPTIVE MATTER THEREIN IS COMMUNICATED IN CONFIDENCE AND IS THE COPYRIGHT PROPERTY OF EUROPEAN SAFETY SYSTEMS LTD. NEITHER THE WHOLE OR ANY EXTRACT MAY BE DISCLOSED, LOANED, COPIED OR USED FOR MANUFACTURING OR TENDERING PURPOSES WITHOUT THEIR WRITTEN CONSENT.

EUROPEAN SAFETY SYSTEMS LTD.  
 AS PER LATEST DATE OF ISSUE SHOWN ABOVE

**e2s**  
 warning signals  
 EUROPEAN SAFETY SYSTEMS LTD  
 IMPRESS HOUSE  
 MANSELL ROAD  
 ACTON  
 LONDON W3 7QH  
 WWW.E2S.COM

ALL DIMENSIONS IN MM  
 IF IN DOUBT, ASK -  
 DO NOT SCALE



**A2**

**TITLE** D2xP1 STACK - 2 BEACONS WITH  
 JUNCTION BOX WIRING SCHEMATIC

<b>SCALE</b>	<b>SHEET</b>	<b>DRAWING NUMBER</b>
NTS	1 OF 2	D215-06-132

# AC CONFIGURATIONS

ISSUE	MOD No.	REASON - INITIAL - DATE
1		SEE SH1
2		SEE SH1
3		SEE SH1

## CONFIG. 1 (DEFAULT)

AC VOLTAGE SUPPLY  
COMMON NEUTRAL CONNECTION TO ALL SIGNALS

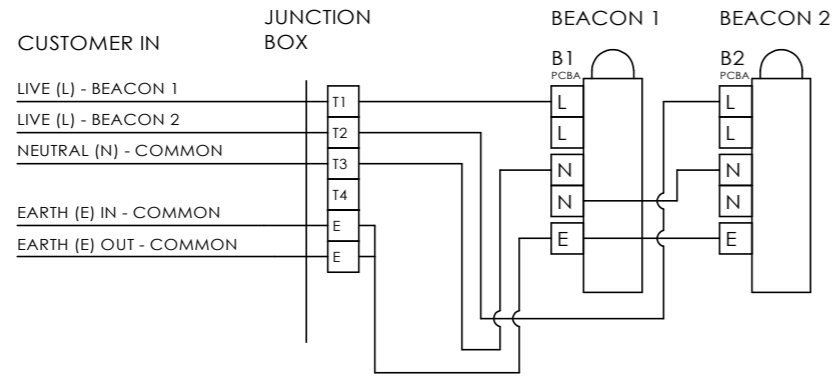

## CONFIG. 2

AC VOLTAGE SUPPLY  
INDEPENDENT CONNECTIONS TO ALL SIGNALS

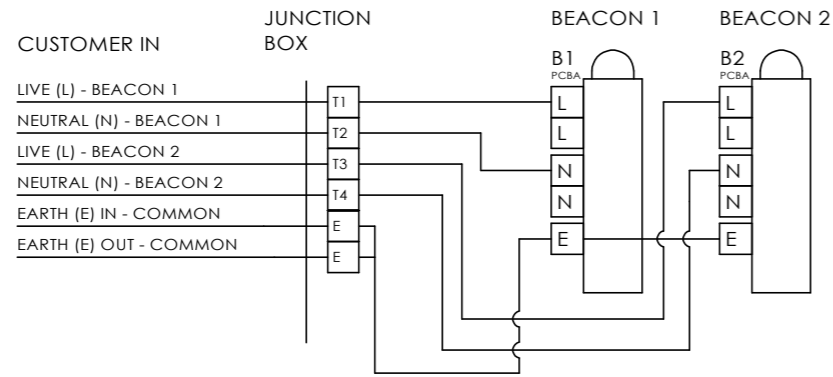

DRAWING TO BS8888:2000  
GEOMETRIC TOLERANCES TO ISO1101:1983  
LINEAR DIMENSIONAL TOLS  
ANGULAR DIMENSIONAL TOLS

DRAWN	DATE
D.HOWGILL	15-08-2019
CHECKED	DATE
R.N.POTTS	15-08-2019
APPROVED	DATE
R.N.POTTS	15-08-2019

SURFACE FINISH	WEIGHT (kg)
FINISH	
MATERIAL	
ALTERNATIVE MATERIAL	

THIS DRAWING AND ANY INFORMATION OR DESCRIPTIVE MATTER THEREIN IS COMMUNICATED IN CONFIDENCE AND IS THE COPYRIGHT PROPERTY OF EUROPEAN SAFETY SYSTEMS LTD. NEITHER THE WHOLE OR ANY EXTRACT MAY BE DISCLOSED, LOANED, COPIED OR USED FOR MANUFACTURING OR TENDERING PURPOSES WITHOUT THEIR WRITTEN CONSENT.

EUROPEAN SAFETY SYSTEMS LTD.  
AS PER LATEST DATE OF ISSUE SHOWN ABOVE

**e2s**  
warning signals

EUROPEAN SAFETY SYSTEMS LTD  
IMPRESS HOUSE  
MANSELL ROAD  
ACTON  
LONDON W3 7QH  
WWW.E2S.COM

ALL DIMENSIONS IN MM IF IN DOUBT, ASK - DO NOT SCALE			<b>A2</b>
TITLE D2xP1 STACK - 2 BEACONS WITH JUNCTION BOX WIRING SCHEMATIC			
SCALE NTS	SHEET 2 OF 2	DRAWING NUMBER D215-06-132	