

# TAG DIMENSIONS

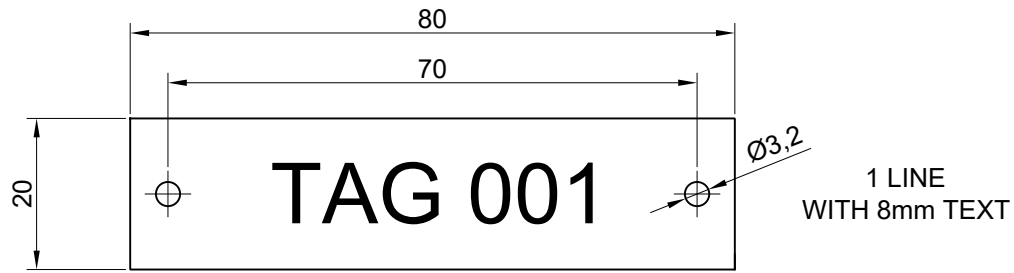

1 LINE  
WITH 8mm TEXT



1 LINE  
WITH 5mm TEXT

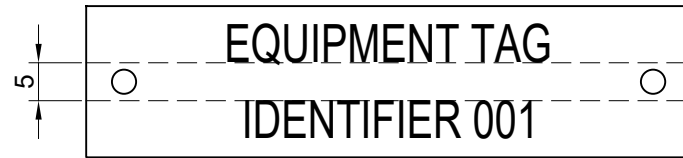

2 LINES

NOTE: CHARACTER LIMIT INCLUDES SPACES

# TAG SPECIFICATIONS

|       |         |                             |
|-------|---------|-----------------------------|
| ISSUE | MOD No. | INITIAL/DATE                |
| 1     |         | INTRODUCTION<br>MM 28-02-24 |

| LINES     | TEXT HEIGHT | TOTAL NO. OF CHARACTERS |
|-----------|-------------|-------------------------|
| ONE LINE  | 8           | 14                      |
|           | 5           | 25                      |
| TWO LINES | 5           | UP TO 50                |

FONT: ARIAL  
METHOD OF MARKING: LASER ETCHED WITH BLACK TEXT  
PLATE MATERIAL: GRADE 316 STAINLESS STEEL  
ATTACHMENT: NYLON COATED STAINLESS STEEL WIRE  
POSITION: SEE DIAGRAMS BELOW

NOTE 1: CHARACTER LIMIT INCLUDES SPACES  
NOTE 2: TEXT HEIGHT WILL BE PRIORITISED FOR LABEL CONTENTS WHERE POSSIBLE

DISCLAIMER: UNLESS OTHERWISE SPECIFIED, LABEL CONTENTS WILL BE SIZED FOR BEST FIT AS DEEMED APPROPRIATE BY E2S

# TAG POSITION

BEACONS

CRIMPED TO A FASTENER SCREWED TO THE UNIT

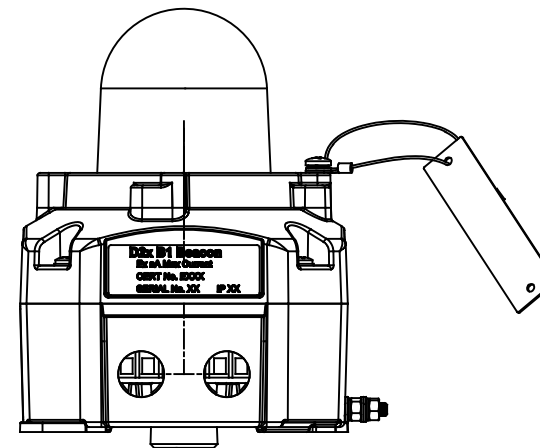

DRAWING TO BS8888:2000  
GEOMETRIC TOLERANCES TO ISO1101:1983  
LINEAR DIMENSIONAL TOLS +/-0.35mm  
ANGULAR DIMENSIONAL TOLS +/-2 deg

DRAWN DATE 28-02-24  
M.MUSU  
CHECKED DATE 28-02-24  
R.N.POTTS  
APPROVED DATE 28-02-24  
R.N.POTTS

SURFACE FINISH WEIGHT (Kg)  
MATERIAL SEE NOTE  
ALTERNATIVE MATERIAL

THIS DRAWING AND ANY INFORMATION OR DESCRIPTIVE MATTER THEREIN IS COMMUNICATED IN CONFIDENCE AND IS THE COPYRIGHT PROPERTY OF EUROPEAN SAFETY SYSTEMS LTD. NEITHER THE WHOLE OR ANY EXTRACT MAY BE DISCLOSED, LOANED, COPIED OR USED FOR MANUFACTURING OR TENDERING PURPOSES WITHOUT THEIR WRITTEN CONSENT.

© EUROPEAN SAFETY SYSTEMS LTD.  
AS PER LATEST DATE OF ISSUE SHOWN ABOVE



EUROPEAN SAFETY SYSTEMS LTD  
IMPRESS HOUSE  
MANSELL ROAD  
ACTON  
LONDON W3 7QH  
WWW.E2S.COM

ALL DIMENSIONS IN MM  
IF IN DOUBT, ASK -  
DO NOT SCALE

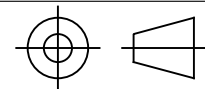

A3

TITLE TAG PLATE SPECIFICATION DRAWING FOR BEACON

SCALE 1:1 SHEET 1 of 1 DRAWING NUMBER D254-00-141