

INSTRUCTION MANUAL

D1xB2X05, D1xB2X10, D1xB2X15 & D1xB2X21

Xenon Beacons

For use in Hazardous Locations

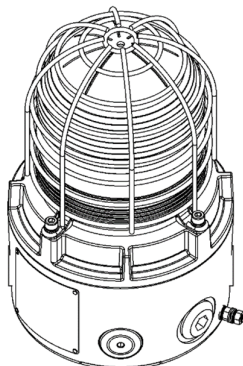

**D1xB2X05
D1xB2X10
D1xB2X15
D1xB2X21**

1) Warnings



- DO NOT OPEN WHEN AN EXPLOSIVE ATMOSPHERE IS PRESENT
- DO NOT OPEN WHEN ENERGISED
- POTENTIAL ELECTROSTATIC CHARGING HAZARD - CLEAN ONLY WITH A DAMP CLOTH
- HIGH VOLTAGE SHOCK HAZARD. WAIT 5 MINUTES AFTER REMOVING POWER BEFORE OPENING THE ENCLOSURE
- DO NOT PAINT
- TO REDUCE THE RISK OF IGNITION OF HAZARDOUS ATMOSPHERES, THE FIRST CONDUIT RUN MUST HAVE A SEALING FITTING CONNECTED WITHIN 18 INCHES OF ENCLOSURE. SUBSEQUENT CONDUIT RUNS MUST HAVE A SEALING FITTING CONNECTED AS CLOSE AS PRACTICAL TO THE WALL OF THE ENCLOSURE, BUT IN NO CASE MORE THAN THE SIZE OF THE CONDUIT OR 50MM, WHICHEVER IS THE LESSER.
- TO PREVENT IGNITION OF GROUP A, B, C AND D ATMOSPHERES - SEE INSTRUCTION FOR CHEMICAL COMPATIBILITY

Avertissement:

- NE PAS OUVRIR UN PRESENCE D'ATMOSPHERE EXPLOSIVE
- NE PAS OUVRIR ENERGIE
- DANGER POTENTIEL CHARGE ÉLECTROSTATIQUE - NETTOYER UNIQUEMENT AVEC UN CHIFFON HUMIDE
- HAUT TENSION, RISK DE CHOC. ATTENDEZ 5 MINUTES APRES AVOIR DEBRANCHE L'ALIMENTATION AVANT D'OUVRIR LA BOITIER
- NE PAS PEINTURER
- POUR RÉDUIRE LE RISQUE D'INFLAMMATION DES ATMOSPHÈRES DANGEREUSES, LE PREMIER CONDUIT DE CONDUIT DOIVENT AVOIR UN RACCORD D'ÉTANCHÉITÉ RACCORDÉ À MOINS DE 18

POUCES DE L'ENFERMEMENT. POUR SUBSÉQUENT LES CONDUITES DE CONDUIT LA DISTANCE ENTRE LA SURFACE DE LA MASSE DE REMPLISSAGE AU PLUS PRÈS DE L'ENVELOPPE DOIT ÊTRE AUSSI PETITE QUE CE QUI EST RÉALISABLE MAIS EN AUCUN CAS SUPÉRIEURE À LA PLUS PETITE DES DIMENSIONS CORRESPONDANT À LA TAILLE DU CONDUIT OU À 50 MM.

- POUR PRÉVENIR L'INFLAMMATION DES ATMOSPHÈRES DES GROUPES A, B, C ET D-VOIR L'INSTRUCTION POUR LA COMPATIBILITÉ CHIMIQUE

2) Rating & Marking Information

2.1 Fire Alarm Ratings

The Following models are certified as visual alarm devices for fire alarm use – private mode visual alarm devices in accordance with UL1638 / CAN/ULC-S526 when used with Clear or Red lens covers:

D1xB2X05DC024 / D1xB2X10DC024 / D1xB2X15DC024 / D1xB2X21DC024

On-axis light output per UL1638:

Model D1XB2	Light Intensity in cd	
	Clear Lens	Red Lens
X05DC024 - 1Hz	20.44	5.89
X05DC024 - 1.33Hz	14.47	4.17
X05DC024 - 1.5Hz	11.1	2.13
X10DC024 - 1Hz	69.81	23.66
X10DC024 - 1.33Hz	49.42	16.75
X10DC024 - 1.5Hz	35.71	8.57
X15DC024 - 1Hz	98.61	31.83
2X15DC024 - 1.33Hz	69.81	22.53
X15DC024 - 1.5Hz	50.44	11.53
X21DC024 - 1Hz	215.85	70.74
X21DC024 - 1.33Hz	155.12	50.84
X21DC024 - 1.5Hz	137.47	45.05

2.2 Surge Current Ratings for use in Fire Alarm Systems

Model D1XB2	Nominal Voltage	Voltage Range	Flash Rate	Peak Surge current	RMS surge current
X05DC024	24Vdc	20-28Vdc	1Hz	955mA	370mA
			1.33Hz	960mA	370mA
			1.5Hz	955mA	365mA
			Double	960mA	355mA
X10DC024	24Vdc	20-28Vdc	1Hz	970mA	700mA
			1.33Hz	970mA	700mA
			1.5Hz	990mA	700mA
			Double	990mA	695mA
X15DC024	24Vdc	20-28Vdc	1Hz	990mA	925mA
			1.33Hz	990mA	930mA
			1.5Hz	990mA	925mA
			Double	990mA	905mA
X21DC024	24Vdc	20-28Vdc	1Hz	1590mA	1220mA
			1.33Hz	1710mA	1240mA
			1.5Hz	1590mA	1240mA
			Double	1650mA	1200mA

2.3 NEC & CEC Class / Division Ratings for US / Canada

The D1xB2X Xenon beacons comply with the following standards:

UL 1203 (Ed. 5) 2018
 UL1638A (Ed. 1) 2016
 UL1638 (Ed. 5) 2017
 CSA C22.2 No. 30-M1986 (Ed. 3) 2016
 CSA C22.2 No. 25 (Ed. 4) 2017
 CSA C22.2 No. 205 (Ed. 3) 2017

The D1xB2X05DC012, D1xB2X05DC024 & D1xB2X05DC048 Xenon Beacons are rated as follows:

Class I Div 1 Group ABCD T5 Ta -55°C to +80°C
 Class I Div 1 Group ABCD T6 Ta -55°C to +65°C
 Class II Div 1 Group EFG T5 Ta -55°C to +80°C
 Class III Div 1 Ta -55°C to +80°C

The D1xB2X05AC115 & D1xB2X05AC230 Xenon Beacons are rated as follows:

Class I Div 1 Group ABCD T4A Ta -55°C to +70°C
 Class I Div 1 Group ABCD T5 Ta -55°C to +55°C
 Class I Div 1 Group ABCD T6 Ta -55°C to +40°C
 Class II Div 1 Group EFG T4 Ta -55°C to +40°C
 Class III Div 1 Ta -55°C to +40°C

The D1xB2X10DC024 & D1xB2X10DC048 Xenon Beacons are rated as follows:

Class I Div 1 Group ABCD T4 Ta -55°C to +80°C
 Class I Div 1 Group ABCD T4A Ta -55°C to +70°C
 Class I Div 1 Group ABCD T5 Ta -55°C to +50°C
 Class II Div 1 Group EFG T4 Ta -55°C to +80°C
 Class III Div 1 Ta -55°C to +80°C

The D1xB2X10AC115 & D1xB2X10AC230 Xenon Beacons are rated as follows:

Class I Div 1 Group ABCD T4 Ta -55°C to +70°C
 Class I Div 1 Group ABCD T4A Ta -55°C to +55°C
 Class II Div 1 Group EFG T4 Ta -55°C to +40°C
 Class III Div 1 Ta -55°C to +40°C

The D1xB2X15DC024 & D1xB2X15DC048 Xenon Beacons are rated as follows:

Class I Div 1 Group ABCD T3C Ta -55°C to +80°C
 Class I Div 1 Group ABCD T4 Ta -55°C to +55°C
 Class II Div 1 Group EFG T4 Ta -55°C to +80°C
 Class III Div 1 Ta -55°C to +80°C

The D1xB2X15AC115 & D1xB2X15AC230 Xenon Beacons are rated as follows:

Class I Div 1 Group ABCD T4 Ta -55°C to +70°C
 Class I Div 1 Group ABCD T4A Ta -55°C to +55°C
 Class II Div 1 Group EFG T4 Ta -55°C to +40°C
 Class III Div 1 Ta -55°C to +40°C

The D1xB2X21DC024 & D1xB2X21DC048 Xenon Beacons are rated as follows:

Class I Div 1 Group ABCD T3B Ta -55°C to +80°C
 Class I Div 1 Group ABCD T3C Ta -55°C to +75°C
 Class I Div 1 Group ABCD T4 Ta -55°C to +50°C
 Class II Div 1 Group EFG T3C Ta -55°C to +40°C
 Class III Div 1 Ta -55°C to +40°C

The D1xB2X21AC115 & D1xB2X21AC230 Xenon Beacons are rated as follows:

Class I Div 1 Group ABCD T3C Ta -55°C to +60°C
 Class I Div 1 Group ABCD T4 Ta -55°C to +55°C
 Class I Div 1 Group ABCD T4A Ta -55°C to +40°C
 Class II Div 1 Group EFG T4 Ta -55°C to +40°C
 Class III Div 1 Ta -55°C to +40°C

Installation must be carried out in compliance with the National Electric Code / Canadian Electric Code

2.4 NEC Class / Zone ratings US

The D1xB2X Xenon beacons comply with the following standards:

UL 60079-0 (Ed. 6) 2017
 UL 60079-1 (Ed. 7) 2015
 UL 60079-31 (Ed. 2) 2015

The D1xB2X05DC012, D1xB2X05DC024 & D1xB2X05DC048 Xenon Beacons are rated as follows:

Class I Zone 1 AEx db IIC T4 Ta -55°C to +80°C
 Class I Zone 1 AEx db IIC T5 Ta -55°C to +75°C
 Class I Zone 1 AEx db IIC T6 Ta -55°C to +60°C
 Zone 21 AEx tb IIIC T99°C Ta -55°C to +80°C

The D1xB2X05AC115 & D1xB2X05AC230 Xenon Beacons are rated as follows:

Class I Zone 1 AEx db IIC T4 Ta -55°C to +70°C
 Class I Zone 1 AEx db IIC T5 Ta -55°C to +50°C
 Zone 21 AEx tb IIIC T153°C Ta -55°C to +70°C

The D1xB2X10DC024 & D1xB2X10DC048 Xenon Beacons are rated as follows:

Class I Zone 1 AEx db IIC T4 Ta -55°C to +80°C
Class I Zone 1 AEx db IIC T5 Ta -55°C to +45°C
Zone 21 AEx tb IIIC T132°C Ta -55°C to +80°C

The D1xB2X10AC115 & D1xB2X10AC230 Xenon Beacons are rated as follows:

Class I Zone 1 AEx db IIC T3 Ta -55°C to +70°C
Class I Zone 1 AEx db IIC T4 Ta -55°C to +65°C
Zone 21 AEx tb IIIC T153°C Ta -55°C to +70°C

The D1xB2X15DC024 & D1xB2X15DC048 Xenon Beacons are rated as follows:

Class I Zone 1 AEx db IIC T3 Ta -55°C to +80°C
Class I Zone 1 AEx db IIC T4 Ta -55°C to +65°C
Zone 21 AEx tb IIIC T132°C Ta -55°C to +80°C

The D1xB2X15AC115 & D1xB2X15AC230 Xenon Beacons are rated as follows:

Class I Zone 1 AEx db IIC T3 Ta -55°C to +70°C
Class I Zone 1 AEx db IIC T4 Ta -55°C to +65°C
Zone 21 AEx tb IIIC T153°C Ta -55°C to +70°C

The D1xB2X21DC024 & D1xB2X21DC048 Xenon Beacons are rated as follows:

Class I Zone 1 AEx db IIC T3 Ta -55°C to +80°C
Class I Zone 1 AEx db IIC T4 Ta -55°C to +45°C
Zone 21 AEx tb IIIC T181°C Ta -55°C to +80°C

The D1xB2X21AC115 & D1xB2X21AC230 Xenon Beacons are rated as follows:

Class I Zone 1 AEx db IIC T3 Ta -55°C to +60°C
Class I Zone 1 AEx db IIC T4 Ta -55°C to +50°C
Zone 21 AEx tb IIIC T153°C Ta -55°C to +60°C

Installation must be carried out in compliance with the National Electric Code.

2.5 CEC Class / Zone ratings Canada

The D1xB2X Xenon beacons comply with the following standards:

CAN/CSA C22.2 No. 60079-0 (Ed. 3) 2015
CAN/CSA C22.2 No. 60079-1 (Ed. 3) 2016
CAN/CSA C22.2 No. 60079-31 (Ed. 2) 2015

The D1xB2X05DC012, D1xB2X05DC024 & D1xB2X05DC048 Xenon Beacons are rated as follows:

Ex db IIC T4 Ta -55°C to +80°C
Ex db IIC T5 Ta -55°C to +75°C
Ex db IIC T6 Ta -55°C to +60°C
Ex tb IIIC T99°C Ta -55°C to +80°C

The D1xB2X05AC115 & D1xB2X05AC230 Xenon Beacons are rated as follows:

Ex db IIC T4 Ta -55°C to +70°C
Ex db IIC T5 Ta -55°C to +50°C
Ex tb IIIC T153°C Ta -55°C to +70°C

The D1xB2X10DC024 & D1xB2X10DC048 Xenon Beacons are rated as follows:

Ex db IIC T4 Ta -55°C to +80°C
Ex db IIC T5 Ta -55°C to +45°C
Ex tb IIIC T132°C Ta -55°C to +80°C

The D1xB2X10AC115 & D1xB2X10AC230 Xenon Beacons are rated as follows:

Ex db IIC T3 Ta -55°C to +70°C
Ex db IIC T4 Ta -55°C to +65°C
Ex tb IIIC T153°C Ta -55°C to +70°C

The D1xB2X15DC024 & D1xB2X15DC048 Xenon Beacons are rated as follows:

Ex db IIC T3 Ta -55°C to +80°C
Ex db IIC T4 Ta -55°C to +65°C
Ex tb IIIC T132°C Ta -55°C to +80°C

The D1xB2X15AC115 & D1xB2X15AC230 Xenon Beacons are rated as follows:

Ex db IIC T3 Ta -55°C to +70°C
Ex db IIC T4 Ta -55°C to +65°C
Ex tb IIIC T153°C Ta -55°C to +70°C

The D1xB2X21DC024 & D1xB2X21DC048 Xenon Beacons are rated as follows:

Ex db IIC T3 Ta -55°C to +80°C
Ex db IIC T4 Ta -55°C to +45°C
Ex tb IIIC T181°C Ta -55°C to +80°C

The D1xB2X21AC115 & D1xB2X21AC230 Xenon Beacons are rated as follows:

Ex db IIC T3 Ta -55°C to +60°C
Ex db IIC T4 Ta -55°C to +50°C
Ex tb IIIC T153°C Ta -55°C to +60°C

Installation must be carried out in compliance with the Canadian Electric Code

2.6 ATEX / IECEx & UKEx Certification

The D1xB2X Xenon beacons comply with the following standards:

EN IEC60079-0:2018 / IEC60079-0:2017 (Ed 7)
EN60079-1:2014 / IEC60079-1 (Ed. 7) (2014)
EN60079-31:2014 / IEC60079-31 (Ed. 2) (2013)

The D1xB2X05DC012, D1xB2X05DC024 & D1xB2X05DC048 Xenon Beacons are rated as follows:

Ex db IIC T4 Gb Ta -55°C to +80°C
Ex db IIC T5 Gb Ta -55°C to +75°C
Ex db IIC T6 Gb Ta -55°C to +60°C
Ex tb IIIC T104°C Db Ta -55°C to +80°C

The D1xB2X05AC115 & D1xB2X05AC230 Xenon Beacons are rated as follows:

Ex db IIC T4 Gb Ta -55°C to +70°C
Ex db IIC T5 Gb Ta -55°C to +50°C
Ex tb IIIC T116°C Db Ta -55°C to +70°C

The D1xB2X10DC024 & D1xB2X10DC048 Xenon Beacons are rated as follows:

- Ex db IIC T4 Gb Ta -55°C to +80°C
- Ex db IIC T5 Gb Ta -55°C to +45°C
- Ex tb IIIC T135°C Db Ta -55°C to +80°C

The D1xB2X10AC115, D1xB2X10AC230, D1xB2X15AC115 & D1xB2X15AC230 Xenon Beacons are rated as follows:

- Ex db IIC T3 Gb Ta -55°C to +70°C
- Ex db IIC T4 Gb Ta -55°C to +65°C
- Ex tb IIIC T139°C Db Ta -55°C to +70°C

The D1xB2X15DC024 & D1xB2X15DC048 Xenon Beacons are rated as follows:

- Ex db IIC T3 Gb Ta -55°C to +80°C
- Ex db IIC T4 Gb Ta -55°C to +65°C
- Ex tb IIIC T146°C Db Ta -55°C to +80°C

The D1xB2X21DC024 & D1xB2X21DC048 Xenon Beacons are rated as follows:

- Ex db IIC T3 Gb Ta -55°C to +80°C
- Ex db IIC T4 Gb Ta -55°C to +45°C
- Ex tb IIIC T169°C Db Ta -55°C to +80°C

The D1xB2X21AC115 & D1xB2X21AC230 Xenon Beacons are rated as follows:

- Ex db IIC T3 Gb Ta -55°C to +60°C
- Ex db IIC T4 Gb Ta -55°C to +50°C
- Ex tb IIIC T141°C Db Ta -55°C to +60°C

Certificate No. DEMKO 19 ATEX 2009X
IECEX ULD 19.0006X
UL21UKEX2130X

ATEX Mark, Equipment Group and Category:



CE Marking and Notified Body No.



UKCA Marking and Notified Body No.



The units can be installed in locations with the following conditions:

Area Classification:

Zone 1	Explosive gas air mixture likely to occur in normal operation.
Zone 2	Explosive gas air mixture not likely to occur in normal operation, and if it does, it will only exist for a short time.
Zone 21	Explosive dust air mixture likely to occur in normal operation.
Zone 22	Explosive dust air mixture not likely to occur in normal operation, and if it does, it will only exist for a short time.

Gas Groupings:

Group IIA	Propane
Group IIB	Ethylene
Group IIC	Hydrogen and Acetylene

Temperature Classification:

T1	450°C	
T2	300°C	
T3	200°C	(D1xB2X15DC & D1xB2X21DC up to 80°C ambient, D1xB2X10AC & D1xB2X15AC up to 70°C ambient, D1xB2X21AC up to 60°C ambient)
T4	135°C	(D1xB2X05DC & D1xB2X10DC up to 80°C ambient, D1xB2X05AC up to 70°C ambient, D1xB2X10AC, D1xB2X15DC & D1xB2X15AC up to 65°C ambient, D1xB2X21AC up to 50°C ambient, D1xB2X21DC up to 45°C ambient)
T5	100°C	(D1xB2X05DC up to 75°C ambient, D1xB2X05AC up to 50°C ambient, D1xB2X10DC up to 45°C ambient)
T6	85°C	(D1xB2X05DC up to 60°C ambient)

Dust Groupings:

Group IIIA	Combustible Flyings
Group IIIB	Non-conductive Dust
Group IIIC	Conductive Dust

Maximum Surface Temperature for Dust Applications:

- 104°C (D1xB2X05DC)
- 116°C (D1xB2X05AC)
- 135°C (D1xB2X10DC)
- 139°C (D1xB2X10AC, D1xB2X15AC)
- 141°C (D1xB2X21AC)
- 146°C (D1xB2X15DC)
- 169°C (D1xB2X21DC)

Equipment Category: 2G / 2D

Equipment Protection Level: Gb, Gc, Db, Dc

Ambient Temperature Range:

- 55°C to +80°C (D1xB2X05DC, D1xB2X10DC, D1xB2X15DC, D1xB2X21DC)
- 55°C to +70°C (D1xB2X05AC, D1xB2X10AC, D1xB2X15AC)
- 55°C to +60°C (D1xB2X21AC)

The certification approval has validated continuous use up to 38°C ambient and are for transient use up to 80°C ambient.

2.7 Ingress Protection Ratings

The product is rated for ingress Protection as follows:

IP rating per EN60529: IP66
Type rating per UL50E / NEMA250: 4 / 4X / 3R / 13

Suitable for exposure to Acetone , Ammonium Hydroxide , Diethyl Ether , Ethyl Acetate , Ethylene Dichloride , Furfural, n-hexane , Methyl Ethyl Ketone , Methanol , 2-NitroPropane and Toluene.

To maintain the ingress protection rating, the cable entries must be fitted with suitably rated, certified cable entry and/or blanking devices during installation.

2.8 Electrical Ratings

Model D1xB2	Nom. Voltage	Voltage Range	Nom. operating current [#]	Max Current
X05DC012	12Vdc	12-14Vdc	585	600
X05DC024	24Vdc	20-28Vdc	295	350
X05DC048	48Vdc	42-54Vdc	145	150
X05AC115	115Vac	110-120Vac	140	200
X05AC230	230Vac	220-240Vac	70	100
X10DC024	24Vdc	20-28Vdc	605	710
X10DC048	48Vdc	42-54Vdc	230	250
X10AC115	115Vac	110-120Vac	220	300
X10AC230	230Vac	220-240Vac	130	180
X15DC024	24Vdc	20-28Vdc	835	920
X15DC048	48Vdc	42-54Vdc	330	360
X15AC115	115Vac	110-120Vac	310	420
X15AC230	230Vac	220-240Vac	170	230
X21DC024	24Vdc	20-28Vdc	1130	1240
X21DC048	48Vdc	42-54Vdc	530	560
X21AC115	115Vac	110-120Vac	500	530
X21AC230	230Vac	220-240Vac	195	270

[#]Rated at 1Hz

Table 1: Electrical Ratings

It is important that a suitable power supply is used to run the equipment. The power supply selected must have the necessary capacity to provide the input current to all the units.

The input current will vary according to the voltage input level.

2.9 Marine MED and MER Approval

MED Marking and
Notified Body No.

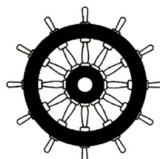

0575/2024

MER Marking and
Notified Body No.



0097/2024

D1xB2X05DC024 units with clear and red lenses have been tested and approved for the installation on ships in the following locations:

Temperature D: Location (-25°C to +70°C)
Vibration A: +/-1mm / 0.7g general applications
EMC A: Bridge and open deck zone
Enclosure: IP66 Outdoor

2.10 DNV TA Approval

D1xB2X05DC024 units with clear and red lenses have been tested and approved for the installation on ships in the following locations:

Temperature: Class A,B,C & D (all locations including open decks and masts)
Humidity: Class A & B (all locations)
Vibration: Class A (all locations except installation on machinery such as combustion engines, compressors, pumps, including piping on such machinery, and masts)
EMC: Class A & B (all locations including open decks and bridge)
Enclosure: Class A, B & C – IP66 (all locations expect submerged applications and bilges)

D1xB2X05DC024 units with clear and red lenses carries Type Approval by DNV to the following guidelines:

Class Guideline DNV-CG-0339:
Environmental test specification for electrical, electronic and programmable equipment and systems

3) Special Conditions of Use

The enclosure coating is non-conductive and may generate an ignition-capable level of electrostatic charges under certain extreme conditions. The user should ensure that the equipment is not installed in a location where it may be subjected to external conditions (such as high pressure steam) which might cause a build-up of electrostatic charges on non-conducting surfaces. Additionally, cleaning of the equipment should be done only with a damp cloth.

Flame Path Positions

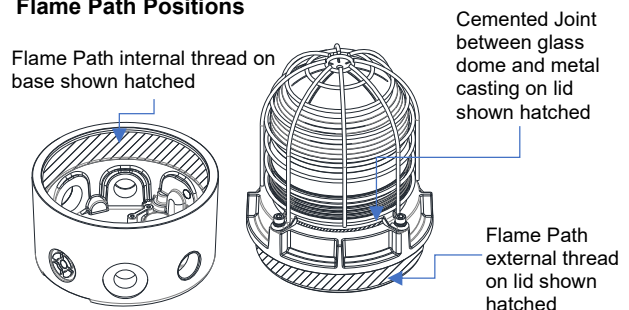

4) Installation

There are no restrictions on unit orientation.

The junction box must only be installed by suitably qualified personnel in accordance with the latest issues of the relevant standards:

EN60079-14 / IEC60079-14: Explosive atmospheres - Electrical installations design, selection and erection

EN60079-10-1 / IEC60079-10-1: Explosive atmospheres - Classification of areas. Explosive gas atmospheres

EN60079-10-2 / IEC60079-10-2: Explosive atmospheres - Classification of areas. Explosive dust atmospheres

The installation of the units must also be in accordance with any local codes that may apply and should only be carried out by a competent electrical engineer who has the necessary training.

4.1 Safe Installation Requirements

To maintain the ingress protection rating and mode of protection, the cable entries must be fitted with suitably certified cable entry and/or blanking devices during installation. If conduit is used for installation, seal conduit within 18 inches from the enclosure.

If entries are fitted with adaptors they must be suitably certified for the application. Fitting of blanking elements into adaptors is not permitted.

Check that the 'O' ring seal is in place before replacing the explosionproof cover.

Lens guard must be fitted for Class Division installations.

5) Location and Mounting

The location of the beacon should be made with due regard to the area over which the warning signal must be visible. It should only be fixed to services that can carry the weight of the unit.

The D1xB2X beacon can be mounted using one of three methods.

1. The beacon can be surface mounted by removing, rotating and reinstalling the stowed mounting lugs. These are suitable for 6mm diameter fixings.
 - a. Remove 2 x M5 fasteners per mounting lug
 - b. Reverse and rotate lug and reseal onto enclosure
 - c. Secure lug using the 2 x M5 Fasteners
2. Alternatively, the beacon can be conduit mounted using the 3/4" NPT entry on the base of the unit.
3. Additionally, the beacon can be mounted using the ratchet adjustable stainless-steel wall bracket assembly. This is available as an accessory – part code: SP77-0001.

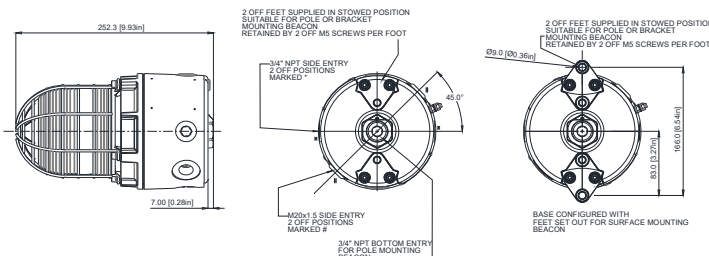

Fig. 1 Fixing Location for Beacon

6) Access to the Enclosure



Warning – High voltage may be present, risk of electric shock. DO NOT open when energised, disconnect power before opening.



Warning – Hot surfaces. External surfaces and internal components may be hot after operation, take care when handling the equipment.

In order to connect the electrical supply cables to the beacon, it is necessary to open the explosion proof enclosure. Loosen the locking grub screw in the cover and then remove the glass dome cover assembly to gain access to the chamber. This can be achieved by unscrewing the glass dome cover, taking extreme care not to damage the threads when doing so.

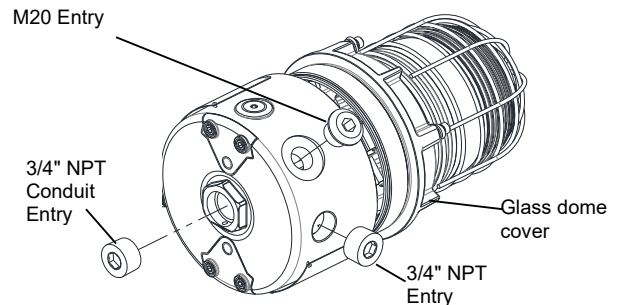

Fig. 2 Accessing the Enclosure.

On completion of the installation the flameproof threads should be inspected to ensure that they are clean and that they have not been damaged during installation. Ensure the O-ring seal is in place and undamaged.

When fitting the flameproof cover ensure the thread is engaged correctly. Fully tighten the cover all the way, ensure no gap is visible between the cover and base of the beacon enclosure.

7) Selection of Cable, Cable Glands, Blanking Elements & Adaptors

When selecting the cable size, consideration must be given to the input current that each unit draws (see section 11), the number of beacons on the line and the length of the cable runs. The cable size selected must have the necessary capacity to provide the input current to all of the beacons connected to the line.

The entries are 2-off M20 x 1.5 thread & 3-off 3/4" NPT thread

If a high IP (Ingress Protection) rating is required then a suitable sealing washer must be fitted under the cable glands or blanking plugs.

For use in explosive dust atmospheres, a minimum ingress protection rating of IP6X must be maintained.

For use in explosive gas atmospheres, a minimum ingress protection rating of IP54 must be maintained. NPT plugs should be greased before insertion.

For high ambient temperatures the cable entry temperature or the cable branching point temperature may exceed 60°C and therefore suitable heat resisting cables and cable glands must be used, with a rated service temperature of at least the values stated below:

Model D1xB2	Max Ambient Temperature (°C)																	
	-5	0	5	10	15	20	25	30	35	40	45	50	55	60	65	70	75	80
X05DC											61	66	71	76	81	86	91	96
X05AC							62	67	72	77	82	87	92	97	102	107	-	-
X10DC							63	68	73	78	83	88	93	98	103	108	113	118
X10AC					63	68	73	78	83	88	93	98	103	108	113	118	-	-
X15DC						64	69	74	79	84	89	94	99	104	109	114	119	124
X15AC	61	66	71	76	81	86	91	96	101	106	111	116	121	126	131	136	-	-
X21DC		65	70	75	80	85	90	95	100	105	110	115	120	125	130	135	140	145
X21AC			65	70	75	80	85	90	95	100	105	110	115	120	-	-	-	-

Table 2: Required Cable/Cable Gland Ratings (°C).

8) Cable Connections

The units have 2-off M20 x 1.5 threaded entries and 3-off 3/4" NPT x 14 threaded entries.

Electrical Connections are to be made into the terminal blocks using solid or stranded wire, sizes 0.5-2.5mm² / AWG 20-14. Wire insulation needs to be stripped 6-7mm. Wires may be fitted securely with crimped ferrules. Terminal screws need to be tightened down with a tightening torque of 0.4 Nm / 3.5 Lb-in.

See section 5 of this manual for access to the enclosure.

9) Wiring

A 4-way terminal block is provided on the DC beacons for power. There are 2-off +ve, 2-off -ve terminal and an internal Earth boss.

See Schematic diagram D191-06-201.

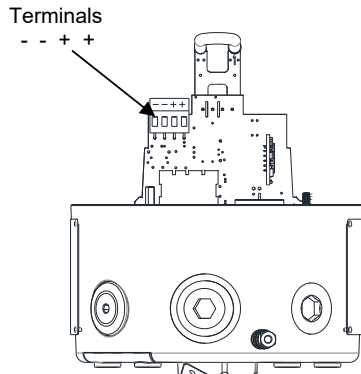

Fig. 3 D1xB2XDC Terminals

A 5-way terminal block is provided on the AC beacons for power. There are 2-off Live, 2-off Neutral and an Earth terminal.

See Schematic diagram D191-06-205.

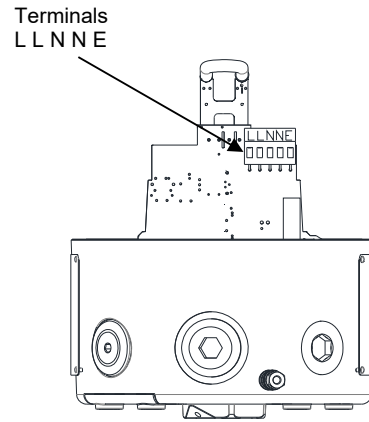

Fig. 4 D1xB2XAC Terminals

9.1 Line Monitoring

On the D2xB1X unit, DC reverse line monitoring can be used if required.

All DC beacons have a blocking diode fitted in their supply input lines. An end of line monitoring resistor can be connected across the +ve and -ve terminals in the explosion proof enclosure. If an end of line resistor is used it must have the following values:

Minimum resistance 3K3 Ohms Minimum Power 0.5W
 Minimum resistance 500 Ohms Minimum Power 2.0W

The resistor must be connected directly across the +ve and -ve terminals as shown in the following drawing. Form the resistor legs as shown in Fig. 5a, fit the resistor across the two terminals, as shown in Fig. 5b.

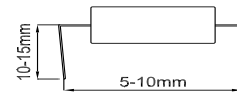

Fig. 5a End of Line Resistor Forming

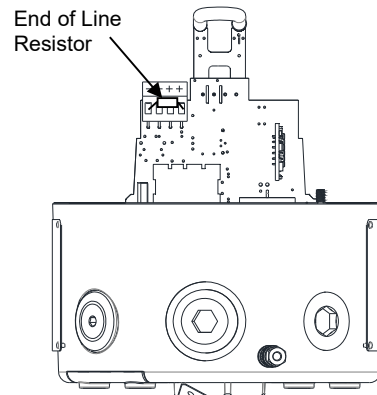

Fig. 5b End of Line Resistor Placement

10) Earthing

The unit has an external and an internal earth terminal, (please see fig 6).

Please note that for AC supply voltage product versions the Earth terminal on the PCBA does not provide an earth connection to the product enclosure. The enclosure must be independently earthed using either the external or internal

Switch Setting	S1 Mode
00	1Hz* (60FPM)
01	1.33Hz (80FPM)
10	1.5Hz (90FPM)
11	Double Flash

1=ON; 0=OFF
 Example shown (Fig.7):
 10 = Flashing 1.5Hz
 (Default setting is 00 1Hz)

earth fixing point, (see fig 6 and notes below).

Internal earthing connections should be made to the internal Earth terminal in the base of the housing using a ring crimped terminal to secure the earth conductor under the earth clamp. The earth conductor should be at least equal in size and rating to the incoming power conductors.

External earthing connections should be made to the M5 earth stud, using a ring crimp terminal to secure the earth conductor to the earth stud. The external earth conductor should be at least 4mm in size.

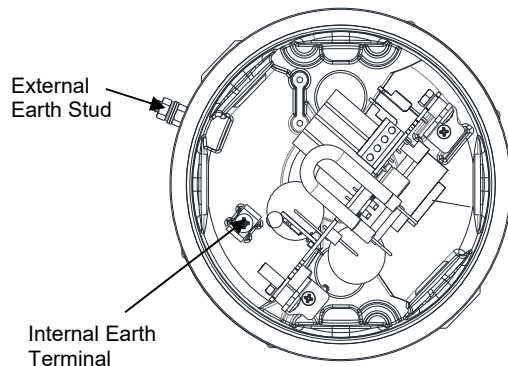

Fig. 6: Internal and External Earth Locations

11) Settings

11.1 Flash Rate Setting



Warning – high-intensity light source. Avoid looking directly at the light source for extended periods of time.

The D1xB2X beacon can produce different flash patterns as shown in Table 1. The flash patterns are selected by operation of the flash setting DIP switch on the PCB, Fig 7.

Note: Only 1Hz flash rate is Private Mode Fire approved

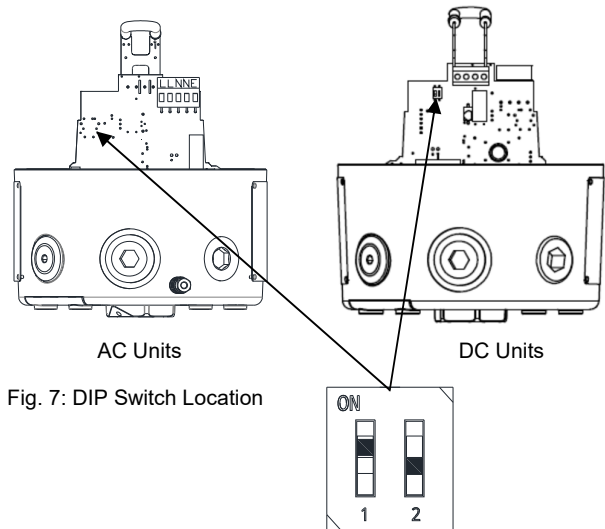

Fig. 7: DIP Switch Location

(*Setting permitted for use as private mode fire alarm device)

Table 3: Switch Positions for Flash Patterns

12) Interchangeable & Spare Parts



Warning – Hot surfaces. External surfaces and internal components may be hot after operation, take care when handling the equipment.

The Beacon lens cover is interchangeable, contact E2S Ltd for a replacement lens cover available in various colours.

To change the lens cover, unscrew the 4-off M5 socket head screws, spring and flat washers using a 4mm Hex key. Remove the wire guard and replace the old lens cover with the new lens cover.

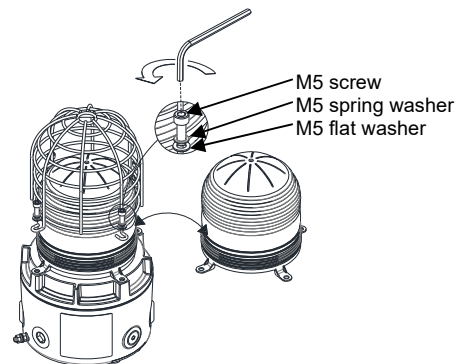

Fig. 8 Replacement of beacon lens cover

Fit the wire guard back onto the housing, over the new lens cover aligning the fixing holes of the guard, lens cover and housing. Refit the fixings to hold into place, the fixings MUST be fitted in the order shown above.

13) Maintenance, Overhaul & Repair

Maintenance, repair and overhaul of the equipment should only be carried out by suitably qualified personnel in accordance with the current relevant standards:

EN60079-19 / IEC60079-19 Explosive atmospheres - Equipment repair, overhaul and reclamation

EN 60079-17 / IEC60079-17 Explosive atmospheres - Electrical installations inspection and maintenance

To avoid a possible ELECTROSTATIC CHARGE the unit must only be cleaned with a damp cloth.

Units must not be opened while an explosive atmosphere is present.

If opening the unit during maintenance operations a clean environment must be maintained and any dust layer removed.

Flameproof joints are not intended to be repaired.

14) SIL 2 Reliability Data

Reliability and Functional safety IEC/EN61508 which has been assessed and is considered suitable for use in low demand safety function:

1. Random Hardware Failures and Architectural constraints (route 2_H).
2. As an unvoted item (i.e. hardware fault tolerance of 0) at SIL 2.

The product was assessed against failure modes:

- Failure respond to an input by lighting a beacon.
 - Spurious light output despite no input.
3. When employing the device in a SIL2 compliant system the user should ensure frequent or continuous automatic monitoring of continuity.

Integrity in respect of failure to function	SIL2 & SIL1
Total Failure rate	0.48 pmh
"Hazardous" failure rate (revealed)	0 pmh
"Hazardous" failure rate (unrevealed)	0.48 pmh
"Safe" failure rate (revealed)	0 pmh
"Safe" failure rate (unrevealed)	0
System type	B
Hardware Fault Tolerance	0
Diagnostic Coverage	>60%
PFD (hazardous failure)	2.1×10^{-3}
Proof Test Interval	Up to 1 year

Construction Product Regulation & UKCA Certification

- D1xB2X05DC024 is compliant to EN54-23:2010
- Alarm devices - VAD for use in fire detection and fire alarm systems installed in and around buildings
- IP Rating: IP33C compliant to EN54-23 (Type 4 / 4X / 3R / 13, IP66/67 independently tested to EN60529:1991)
- Type B Product, For Indoor & Outdoor use
- Observe precautions for handling electrostatic sensitive devices
- Operating Temperature for EN54-23: -25°C to +70°C
- Cable Glands: To order, or customer supplied – Must be suitably sealed and meet minimum IP33C for EN54-23 applications
- Maintenance: None
- Mounting: Units are to be mounted using the 2-off ø9mm holes in the mounting feet.

- Order Code:
D1xB2X05DC024***A1R/C;
D1xB2X05DC024***ATR/C;
D1xB2X05DC024***A1G/C;
D1xB2X05DC024***ATG/C
- Voltage Range: 20-28Vdc
- Nominal Voltage: 24Vdc
- Max Current: 350mA @ 20Vdc
- Max Power: 7W
- DOP: DP-2831-CPR-F4859
- UKCA Cert : 0832-UKCA-CPR-F1783
- EU Cert : 2831-CPR-F4859



- Order Code:
D1xB2X05DC024***A1R/R;
D1xB2X05DC024***ATR/R;
D1xB2X05DC024***A1G/R;
D1xB2X05DC024***ATG/R
- Voltage Range: 20-28Vdc
- Nominal Voltage: 24Vdc
- Max Current: 350mA @ 20Vdc
- Max Power: 7W
- DOP: DP-2831-CPR-F4899
- UKCA Cert : 0832-UKCA-CPR-F1854
- EU Cert : 2831-CPR-F4899



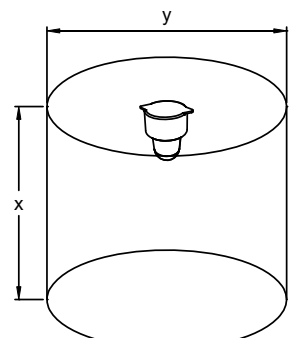

Category C-x-y (Ceiling Class):
Where x is the maximum ceiling height and y the diameter of the cylindrical volume covered by the VAD

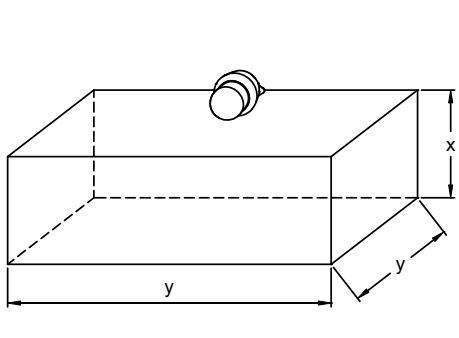

Category W-x-y (Wall Class, foot mounted):
Where x is the maximum mounting height from the floor and y is the maximum length of the sides of the square floor area covered by the VAD.

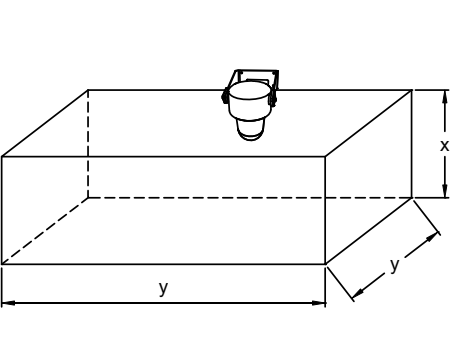

Category W-x-y (Wall Class, bracket mounted):
Where x is the maximum mounting height from the floor and y is the maximum length of the sides of the square floor area covered by the VAD.

Unit	Category C	Category W (Foot Mounted)	Category W (Bracket Mounted)*	Category O
D1xB2X05DC024***A1R/C	C-6-5.55	W-2.4-3.5	W-2.4-5.22	O-3.92-6.7
D1xB2X05DC024***ATR/C	V=145.2m ³	V=29.4m ³	V=65.39m ³	V=102.95m ³
D1xB2X05DC024***A1G/C				
D1xB2X05DC024***ATG/C				
D1xB2X05DC024***A1R/R	C-3-2.92	W-2.4-1.3	W-4-1.47	O-2.05-3.4
D1xB2X05DC024***ATR/R	V=20.1m ³	V=4.05m ³	V=23.52m ³	V=14.28m ³
D1xB2X05DC024***A1G/R				
D1xB2X05DC024***ATG/R				

*Note: Bracket Mount not approved for EN54-23

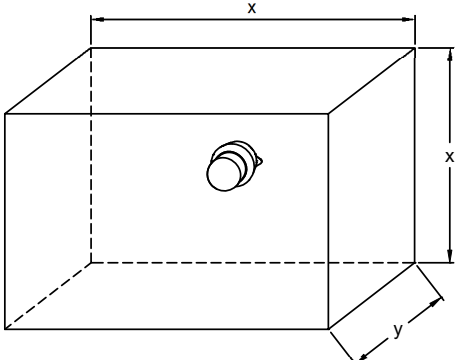

Category O-x-y (Open Class):
Centrally wall mounted, where x is the max height and width of the wall area covered by the device and y is the max depth of the volume covered by the VAD.
Or
Centrally ceiling mounted, where x is the max width and depth of the floor area covered by the device and y is the max ceiling height.

Approved for EN54-23 Applications:



- Clear & Red lenses
- 1Hz flash mode

1	2	3	4	5	6	7	8	9	10
							ISSUE	MOD No.	REASON - INITIAL - DATE
							B		RE-DRAWN IN 2D NOTES, TERMINALS & EOL RESISTOR ADDED DAH 17/12/19
							C		NEW PCBA & FORMAT INTRODUCED J.S - 22/03/21
							D		NEW FORMAT INTRODUCED RSR - 28/11/22

DC XENON D1xB2 X05, X10, X15 & 21J UNITS
Line Monitoring
Power: +ve & -ve

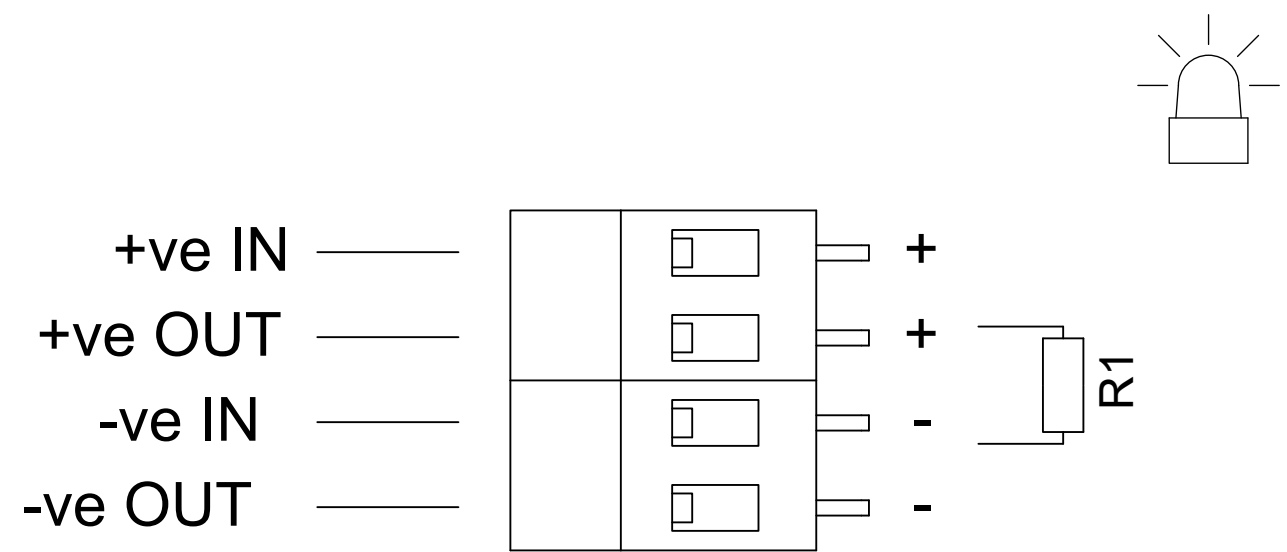
OPTIONAL LINE MONITORING RESISTOR, CUSTOMER SUPPLIED,
RECOMMENDED MINIMUM VALUES:
500Ω MIN, 2W MIN OR 3K3Ω MIN, 0.5W MIN



DRAWING TO BS8888:2000 GEOMETRIC TOLERANCES TO ISO1101:1983 LINEAR DIMENSIONAL TOLS ANGULAR DIMENSIONAL TOLS	DRAWN	DATE	SURFACE FINISH	WEIGHT (Kg)	THIS DRAWING AND ANY INFORMATION OR DESCRIPTIVE MATTER THEREIN IS COMMUNICATED IN CONFIDENCE AND IS THE COPYRIGHT PROPERTY OF EUROPEAN SAFETY SYSTEMS LTD. NEITHER THE WHOLE OR ANY EXTRACT MAY BE DISCLOSED, LOANED, COPIED OR USED FOR MANUFACTURING OR TENDERING PURPOSES WITHOUT THEIR WRITTEN CONSENT.	 warning signals EUROPEAN SAFETY SYSTEMS LTD IMPRESS HOUSE MANSELL ROAD ACTON LONDON W3 7QH WWW.E2S.COM	ALL DIMENSIONS IN MM	 	A3
	R. RAIT	28/11/22	MATERIAL	IF IN DOUBT, ASK - DO NOT SCALE					
	CHECKED	DATE	ALTERNATIVE MATERIAL	TITLE			D1xB2 X05/X10/X15/X21 BEACON WIRING DIAGRAMS		
	STANDARDS	R.N.POTTS	28/11/22	SCALE			NTS	SHEET	1 OF 2
D1xB2 BEACONS	APPROVED	DATE							
	R.N.POTTS	28/11/22							

1	2	3	4	5	6	7	8	9	10
							ISSUE	MOD No.	REASON - INITIAL - DATE
							B		RE-DRAWN IN 2D NOTES, TERMINALS & EOL RESISTOR ADDED DAH 17/12/19
							C		NEW PCBA & FORMAT INTRODUCED J.S - 22/03/21
							D		NEW FORMAT INTRODUCED RSR - 28/11/22

AC XENON D1xB2 X05, X10 & X15 UNITS
Power: Live & Neutral

AC XENON GNExB2 X21 UNITS
Power: Live & Neutral

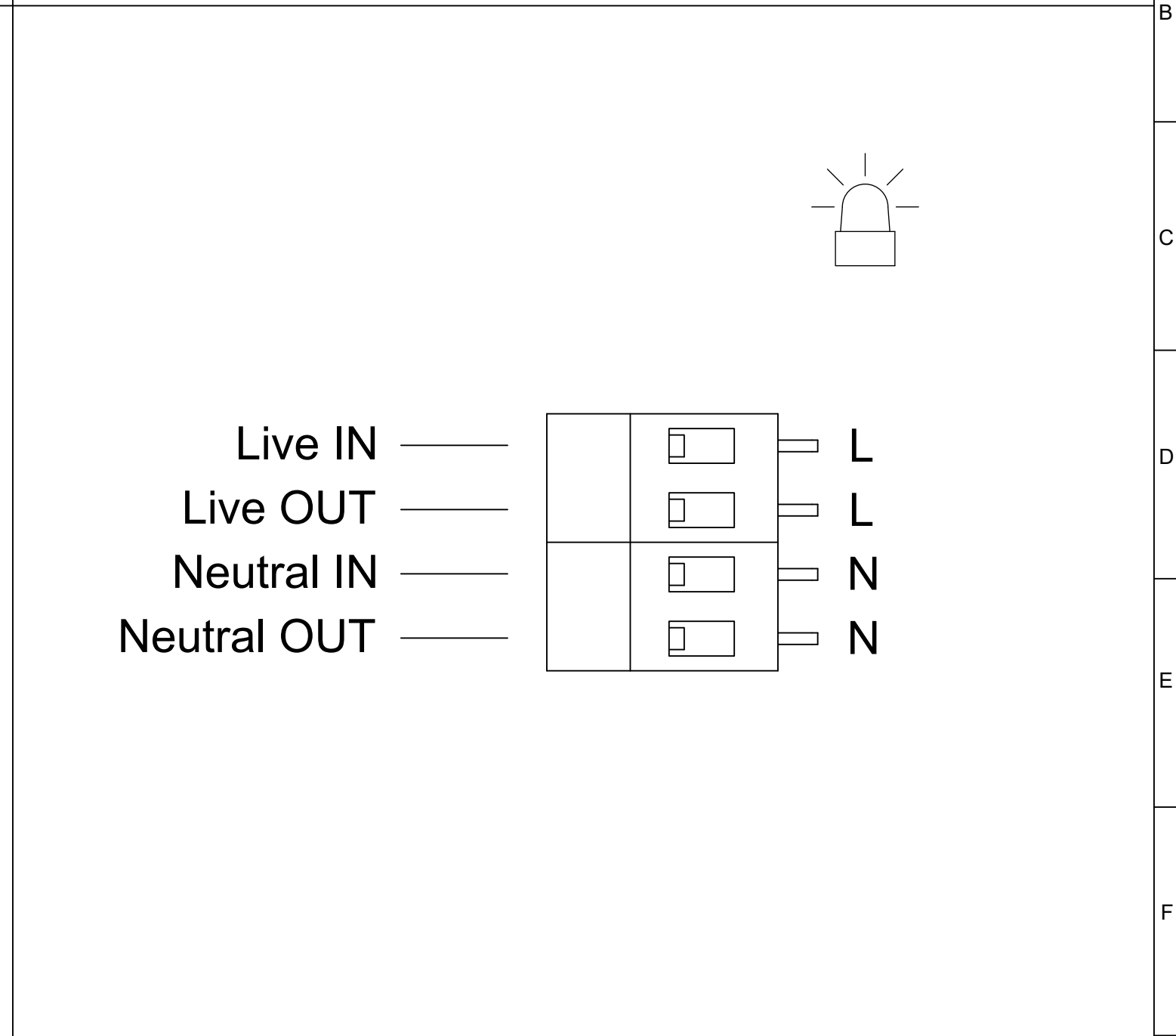
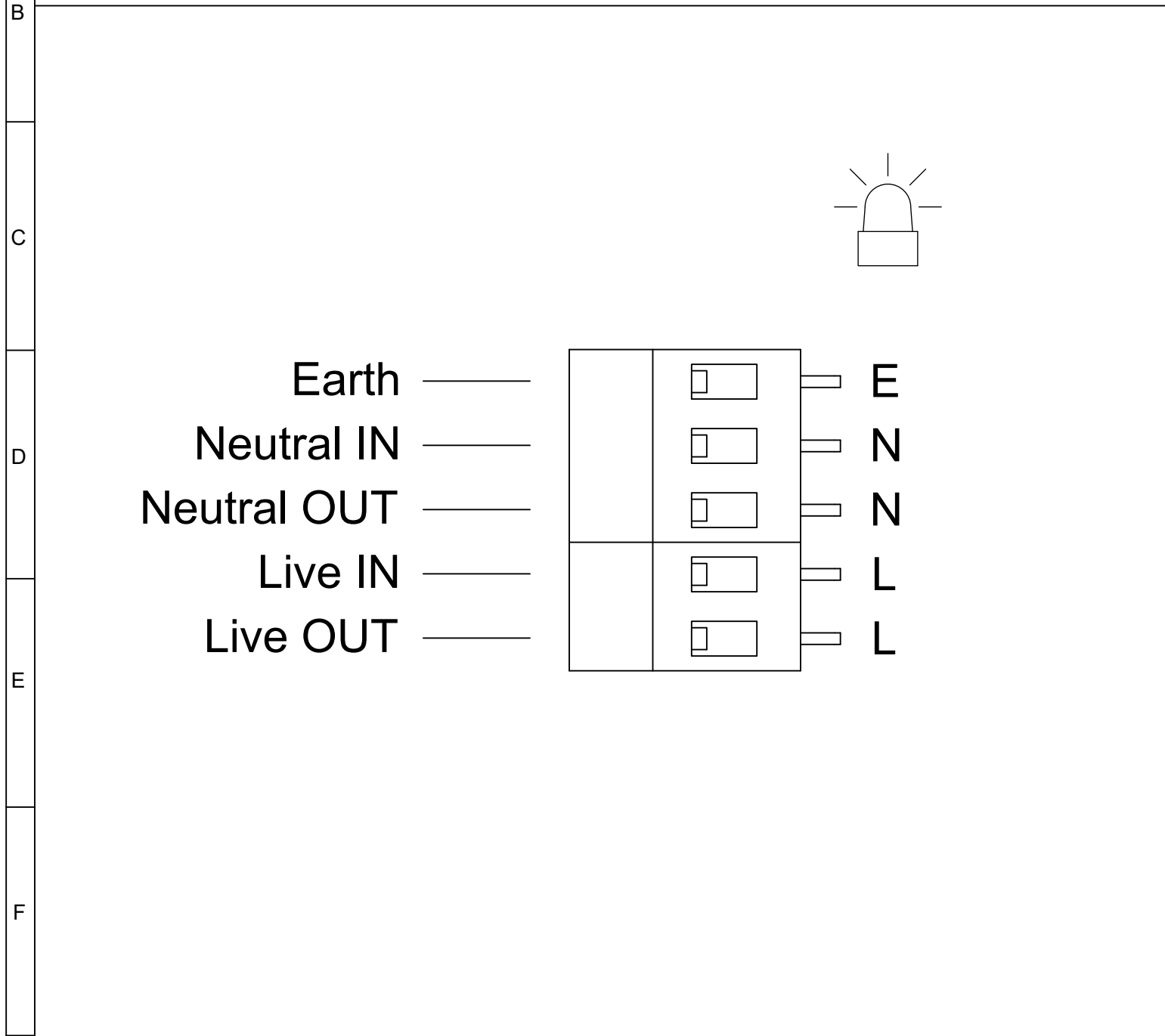

DRAWING TO BS8888:2000 GEOMETRIC TOLERANCES TO ISO1101:1983 LINEAR DIMENSIONAL TOLS ANGULAR DIMENSIONAL TOLS	DRAWN	DATE	SURFACE FINISH	WEIGHT (Kg)	THIS DRAWING AND ANY INFORMATION OR DESCRIPTIVE MATTER THEREIN IS COMMUNICATED IN CONFIDENCE AND IS THE COPYRIGHT PROPERTY OF EUROPEAN SAFETY SYSTEMS LTD. NEITHER THE WHOLE OR ANY EXTRACT MAY BE DISCLOSED, LOANED, COPIED OR USED FOR MANUFACTURING OR TENDERING PURPOSES WITHOUT THEIR WRITTEN CONSENT.	 EUROPEAN SAFETY SYSTEMS LTD IMPRESS HOUSE MANSELL ROAD ACTON LONDON W3 7QH WWW.E2S.COM	ALL DIMENSIONS IN MM IF IN DOUBT, ASK - DO NOT SCALE			A3
	R. RAIT	28/11/22					MATERIAL			
	CHECKED	DATE	ALTERNATIVE MATERIAL				TITLE D1xB2 X05/X10/X15/X21 BEACON WIRING DIAGRAMS			
	R.N.POTTS	28/11/22					SCALE	SHEET	DRAWING NUMBER	
STANDARDS	APPROVED	DATE			NTS	2 OF 2	D191-06-201			
D1xB2 BEACONS	R.N.POTTS	28/11/22								

EU Declaration of Conformity



Manufacturer: European Safety Systems Ltd.
Impress House, Mansell Road, Acton
London, W3 7QH
United Kingdom

Authorised Representative: E2S Warnsignaltechnik UG
Charlottenstrasse 45-51
72764 Reutlingen
Germany

Equipment Type: D1xB2X05, D1xB2X10, D1xB2X15, D1xB2X21, D1xB2LD2, D1xJ2

Directive 2014/34/EU: Equipment and Protective Systems for use in Potentially Explosive Atmospheres (ATEX)

Notified Body for EU type Examination (Module B):	UL International Demko A/S Notified Body No.: 0539 Borupvang 5A, 2750 Ballerup, Denmark
EU-type Examination Certificate (Module B):	DEMKO 19 ATEX 2009X Rev. 1
Notified Body for Quality Assurance Notification / Conformity to EU-type based on quality assurance of the production process (Module D):	Sira Certification Service Notified Body No.: 2813 CSA Group Netherlands B.V, Utrechtseweg 310, 6812 AR, Arnhem, Netherlands
Quality Assurance Notification (Module D):	SIRA 05 ATEX M342
Provisions fulfilled by the equipment:	II 2G Ex d IIC T6...T3 Gb II 2D Ex tb IIIC T95°C...T169°C Db
Standards applied:	EN 60079-0:2018 EN 60079-1:2014 EN 60079-31:2014 IP6X Dust Protection to EN60079-0 / EN60079-31

Regulation EU No. 305/2011: Construction Products Regulation (CPR) –part codes listed below only – 1Hz Flash Mode only

Notified Product Certification Body for Certificate of Constancy of Performance or EC Type Examination Certificate and continuous surveillance, assessment and evaluation of factory production control:	BRE Global Assurance (Ireland) Limited Notified Body No.: 2831 DCU Alpha, Old Finglas Road, Glasnevin, Dublin, D11 KXN4
Certificate of Constancy of Performance or EC Type Examination Certificate:	2831-CPR-F4859 (D1xB2X05DC024***A1R/C, D1xB2X05DC024***A1G/C only) 2831-CPR-F4899 (D1xB2X05DC024***A1R/R, D1xB2X05DC024***A1G/R only)
Standards applied:	EN 54-23:2010

Directive 2014/90/EU: Marine Equipment Directive (MED) – part codes specified only – D1xB2X05DC024***A1R/C ; D1xB2X05DC024***A1R/R ; D1xB2X05DC024***A1G/C ; D1xB2X05DC024***A1G/R

Notified Body for EU type Examination (Module B) and Conformity to EU-type based on quality assurance of the production process (Module D):	DNV AS Notified Body No.: 0575 DNV Høvik, Norway
EU-Certificate Type Examination (Module B):	MEDB000085K
EU Certificate of Conformity for the Quality Assurance System (Module D):	MEDD00000GV
Standards applied:	EN 54-3:2014 incl. A1: 2019 EN 54-23:2010 IEC 60092-504: 2016

EU Declaration of Conformity



IEC 60533: 2015

Directive 2014/30/EU: Electromagnetic Compatibility Directive (EMC)

Standards applied:

EN IEC 61000-6-1:2019 & IEC 61000-6-1:2016
EN IEC 61000-6-2:2019 & IEC 61000-6-2:2016
EN IEC 61000-6-3:2021 & IEC 61000-6-3:2020
EN IEC 61000-6-4:2019 & IEC 61000-6-4:2018

Directive 2011/65/EU: Restriction of the use of certain hazardous substances in electrical and electronic equipment (RoHS)

The product and all the components contained within it are in accordance with the restriction of the use of hazardous substances in electrical and electronic equipment, including amendment by Directive 2015/863/EU.

Regulation (EC) 1907/2006: Registration, Evaluation, Authorisation and Restriction of Chemicals (REACH)

The product and all the components contained within it are free from substances of very high concern.

Other Standards and Regulations

EN 60529:1991 + A1:2000 + A2:2013. - Degrees of protection provided by enclosures (IP code) – enclosure rated IP66/67

On behalf of European Safety Systems Ltd., I declare that, on the date the equipment accompanied by this declaration is placed on the market, the equipment conforms with all technical and regulatory requirements of the above listed directives, regulations and standards.

This Declaration is issued under the sole responsibility of the manufacturer.

A handwritten signature in blue ink, appearing to read 'Desmond Gayler'.

Desmond Gayler
Quality Assurance Manager

Document No.: DC-077_Issue_G
Date and Place of Issue: London, 01/09/2023



UKCA Declaration of Conformity



Manufacturer: European Safety Systems Ltd.
Impress House, Mansell Road, Acton
London, W3 7QH
United Kingdom

Equipment Type: D1xB2X05, D1xB2X10, D1xB2X15, D1xB2X21, D1xB2LD2, D1xJ2

Directive UKSI 2016:1107 (as amended by UKSI 2019:696) – Schedule 3A, Part 1 : Product or Protective System Intended for use in Potentially Explosive Atmospheres (UKCA)

Notified Body for UK type Examination (Module B):	UL International (UK) Ltd Notified Body No.: 0843 Unit 1-3 Horizon Kingsland Business Park, Wade Road, Basingstoke, Hampshire RG24 8AH UK
UK-type Examination Certificate (Module B):	UL21UKEX2130X
Notified Body for Quality Assurance Notification / Conformity to EU-type based on quality assurance of the production process (Module D):	Sira Certification Service Notified Body No.: 0518 Rake Lane, Eccleston, Chester CH4 9JN, UK
Quality Assurance Notification (Module D):	CSAE 22UKQAN0046
Provisions fulfilled by the equipment:	II 2G Ex d IIC T6...T3 Gb II 2D Ex tb IIIC T95°C...T169°C Db
Standards applied:	EN 60079-0:2018 EN 60079-1:2014 EN 60079-31:2014 IP6X Dust Protection to EN60079-0 / EN60079-31

Regulation EU No. 305/2011: Construction Products Regulation (CPR) –part codes listed below only – 1Hz Flash Mode only

Notified Product Certification Body for Certificate of Constancy of Performance or EC Type Examination Certificate and continuous surveillance, assessment and evaluation of factory production control:	BRE Global Limited Notified Body No.: 0832 Bucknalls Lane, Garston, Watord, Hertfordshire, UK, WD25 9XX
Certificate of Constancy of Performance or EC Type Examination Certificate:	0832-UKCA-CPR-F41783 (D1xB2X05DC024***A1R/C, D1xB2X05DC024***A1G/C only) 0832-UKCA-CPR-F1854 (D1xB2X05DC024***A1R/R, D1xB2X05DC024***A1G/R only)
Standards applied:	EN 54-23:2010

UK Merchant Shipping, Marine Equipment Regulation (MER) 2016 SI 2016/1025– part codes specified only - D1xB2X05DC024***A1R/C, D1xB2X05DC024***A1G/C, D1xB2X05DC024***A1R/R, D1xB2X05DC024***A1G/R

Notified Body for UK type Examination (Module B) and Conformity to UK-type based on quality assurance of the production process (Module D):	DNV UK Notified Body No.: 0097 DNV, UK
UK-Certificate Type Examination (Module B):	MERB000085K
UK Certificate of Conformity for the Quality Assurance System (Module D):	MERD00000GV
Standards applied:	EN 54-3:2014 incl. A1: 2019 EN 54-23:2010 IEC 60092-504: 2016 IEC 60533: 2015



UKCA Declaration of Conformity



Directive 2014/30/EU: Electromagnetic Compatibility Directive (EMC)

Standards applied:

EN 61000-6-1:2007
EN 61000-6-2:2005
EN 61000-6-3:2007 / A1:2011 / AC: 2012
EN 61000-6-4:2007 / A1: 2011

Directive 2011/65/EU: Restriction of the use of certain hazardous substances in electrical and electronic equipment (RoHS)

The product and all the components contained within it are in accordance with the restriction of the use of hazardous substances in electrical and electronic equipment, including amendment by Directive 2015/863/EU.

Regulation (EC) 1907/2006: Registration, Evaluation, Authorisation and Restriction of Chemicals (REACH)

The product and all the components contained within it are free from substances of very high concern.

Other Standards and Regulations

EN 60529:1991 + A1:2000 + A2:2013. - Degrees of protection provided by enclosures (IP code) – enclosure rated IP66/67

On behalf of European Safety Systems Ltd., I declare that, on the date the equipment accompanied by this declaration is placed on the market, the equipment conforms with all technical and regulatory requirements of the above listed directives, regulations and standards.

This Declaration is issued under the sole responsibility of the manufacturer.

Desmond Gayler
Quality Assurance Manager

Document No.: DC-096_Issue_C
Date and Place of Issue: London, 18/03/2024