

INSTRUCTION MANUAL

D2xH1-E Heat Detector

Class I & II Div 2 ; UL521 ; CAN/ULC-S530

NEC / CEC / ATEX / IECEx / UKEx Zone 2, 22

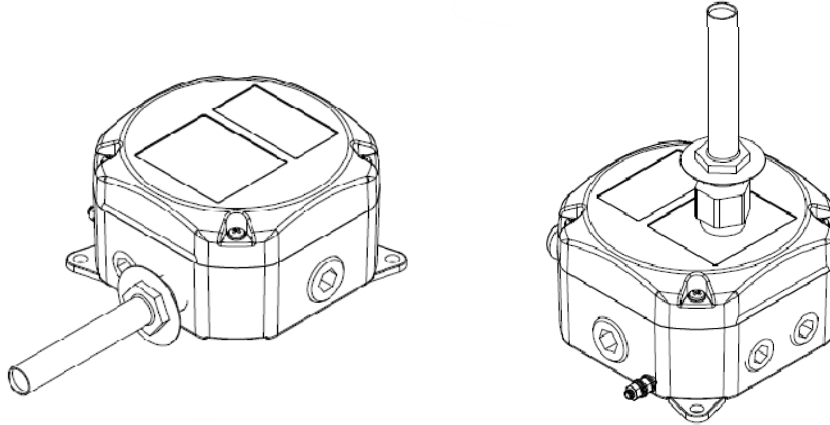

1) Product Table

Unit Type Code	Input Voltage	Max Power
D2xH1-E	32Vac @ 50/60Hz 5.0A 32Vdc / 1.0A Max 24Vdc /2.0A Max	1.25W Max

Table 1: Electrical Ratings

2) Warnings



WARNINGS:

- DO NOT OPEN WHEN AN EXPLOSIVE ATMOSPHERE IS PRESENT
- POTENTIAL ELECTROSTATIC HAZARD – SEE INSTRUCTIO CLEAN ONLY WITH A DAMP CLOTH

AVERTISSEMENT:

- NE PAS OUVRIR UN PRESENCE D'ATMOSPHERE EXPLOSIVE
- DANGER POTENTIEL CHARGE ÉLECTROSTATIQUE - NETTOYER UNIQUEMENT AVEC UN CHIFFON HUMIDE

3) Marking & Rating Information

The D2xH1-E Heat Detectors comply with the following standards for hazardous locations:



All models are approved for Fire Alarm System use:

UL 521
CAN/ULC-S530

3.1 Class/Division Ratings for US & Canada

Standards	
UL 60079-0:2017 (Ed 6): Explosive Atmospheres - Part 0: Equipment - General requirements UL 60079-1:2015 (Ed7): Explosive Atmospheres - Part 1: Equipment protection by flameproof enclosures "d" UL 60079-7:2021 (Ed5): Explosive Atmospheres - Part 7: Equipment protection by increased safety "e" UL 60079-31:2012 (Ed 2): Explosive Atmospheres - Part 31: Equipment dust ignition protection by enclosure "t"	
CSA C22.2 NO. 60079-0:2015 (Ed 3) Explosive Atmospheres – Part 0: Equipment – General requirements CSA C22.2 NO. 60079-1:2016 (Ed 3): Explosive Atmospheres – Part 1: Equipment protection by flameproof enclosures "d" CSA C22.2 NO. 60079-7:2018 (Ed 2): Explosive Atmospheres – Part 7: Equipment protection by increased safety "e" CSA C22.2 NO. 60079-31:2015 (Ed 2): Explosive Atmospheres – Part 31: Equipment dust ignition protection by enclosure "t" UL 121201, Edition 9, Revision Date 04/01/2021 CSA C22.2 No. 213-17, Edition 3, Revision Date 04/01/2021	
Class Division Ratings for US (NEC) & Canada (CEC)	
Model No:	Rating
D2xH1-E	Class I Div 2 GR. ABCD T6 Ta -40°C to +50°C Class II Div 2 GR. FG T6 Ta -40°C to +50°C Class III Div 2 Ta -40°C to +50°C
Class Zone Ratings for US (NEC)	
Model No:	Rating
D2xH1-E	Class I Zone 2 AEx db ec IIC T6 Gc Ta -40°C to +50°C Zone 22 AEx tc IIIB T55°C Dc Ta -40°C to +50°C
Class Zone Ratings for Canada (CEC)	
Model No:	Rating
D2xH1-E	Ex db ec IIC T6 Gc Ta -40°C to +50°C Ex tc IIIC T55°C Dc Ta -40°C to +50°C
Installation must be carried out in compliance with the National Electric Code / Canadian Electric Code	

3.2 ATEX / IECEx & UKEx Ratings

Standards	
EN60079-0:2018/IEC60079-0:2017 (ed.7): Explosive Atmospheres - Equipment General Requirements. EN60079-1:2014/IEC60079-1:2014 (ed.7): Explosive Atmospheres - Equipment Protection by Flameproof Enclosures "d". EN IEC60079-7:2015+A1:2018/IEC60079-7:2017 (ed.5.1): Explosive Atmospheres - Equipment protection by increased safety "e" EN60079-31:2014/IEC60079-31:2022 (ed.3): Explosive Atmospheres - Equipment Dust Ignition Protection by enclosure "t".	
Model No:	Rating
D2xH1-E	Ex db ec IIC T6 Gc Ta -40°C to +50°C Ex tc IIIC T55°C Dc Ta -40°C to +50°C
See Product table for electrical ratings of each unit model	

Certificate No. DEMKO 14 ATEX 4786493904X
IECEx ULD 14.0004X
UL21UKEX2131X

Epsilon x
Equipment Group
and Category:

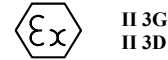

CE Marking and
Notified Body No.



UKCA Marking and
Notified Body No.



4) Zones, Gas Group, Category and Temperature Classification

The units can be installed in locations with the following conditions:

Area Classification Gas	
Zone 2	Explosive gas air mixture not likely to occur in normal operation, and if it does, it will only exist for a short time.
Gas Groupings	
Group IIA	Propane
Group IIB	Ethylene
Group IIC	Hydrogen and Acetylene
Temperature Classification for Gas Applications	
T1	450° C
T2	300° C
T3	200° C
T4	135° C
T5	100°C
T6	85°C
Area Classification Dust	
Zone 22	Explosive dust air mixture not likely to occur in normal operation, and if it does, it will only exist for a short time.
Dust Groupings	
Group IIIA	Combustible Dusts
Group IIIB	Non-Conductive Dusts
Group IIIC	Conductive Dusts
Equipment Category	
3G, 3D	
Equipment Protection Level	
Ge, Dc	
Maximum Surface Temperature for Dust Applications	
T55°C	
Ambient Temperature Range	
-40°C to +50°C (-40°F to +122°F)	
IP Rating	
IP66/67 to EN/IEC60529 and IP66 to EN/IEC60079-0, EN/IEC60079-31 4 / 4X / 3R / 13 to UL50E / NEMA250	

5) Special Conditions of Use

Special Condition for safe Use as stated on the Type Examination Certificate DEMKO 14 ATEX 4786493904X / IECEx ULD 14.0004X & UL21UKEX2131X

When used for a Group III application, the surface of the enclosure may store electrostatic charge and become a source of ignition in applications with a low relative humidity <~30% relative humidity where the surface is relatively free of surface contamination such as dirt, dust, or oil.

Guidance on protection against the risk of ignition due to electrostatic discharge can be found in EN TR50404 and IEC TR60079-32.

End user shall adhere to the manufacturer's installation and instruction when performing housekeeping to avoid the potential for hazardous electrostatic charges during cleaning, by using a damp cloth.

End of line monitoring diode or an end of line monitoring resistor can be connected across the +ve and –ve terminals.

These must maintain creepage and clearance distances to bare conductive parts at different potentials, of at least 1.8mm.

6) Location and Mounting

The location of the heat detector should enable ease of access for operation and testing. They should only be fixed to services that can carry the weight of the unit.

The D2xH1 Heat Detector should be secured to any flat surface using the two 7mm fixing holes in the feet of the base. The 2-off feet must first be fitted to the base using the 2-off M4 X 12mm countersunk screws provided. See Fig. 1.

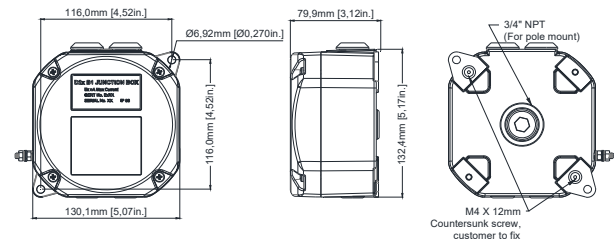

Fig. 1 Fixing Locations for Junction Box

The Heat detector element / shell should be mounted with the following consideration :-

The Heat Detector is fitted in an area (normally ceiling) so that:-

- The thermal air path to the shell is not obstructed.
- The heat detectors spacing complies with both system requirements and requirements of the local authority having jurisdiction.
- The element shell is not position sensitive, so can be mounted either vertically or horizontally depending on the application and installation requirements.

There are two heat detector orientations on the D2xH1-E unit. Option : Detector orientation [d] :

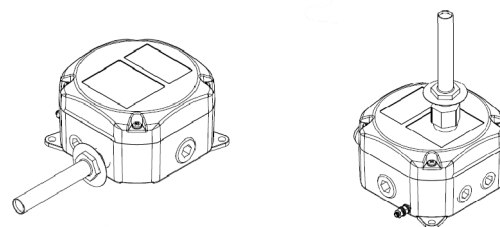

[d] = H which is horizontal

[d] = V which is vertical

7) Access to the Enclosure



Warning – High voltage may be present, risk of electric shock. DO NOT open when energised, disconnect power before opening.

To access the enclosure, loosen the four M4 posi pan head screws and withdraw the cover.

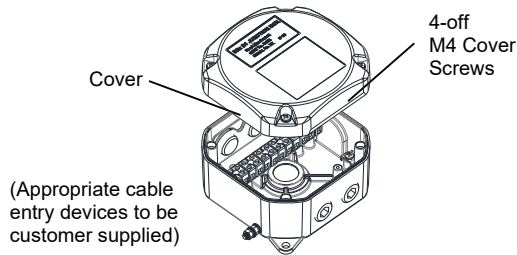

Fig. 2 Accessing the Enclosure.

To replace cover, check that the 'O' ring seal is in place and undamaged.

Carefully push the cover in place. Insert M4 screws with fibre washers and tighten to 3Nm torque.

8) Earthing

The unit has both internal and external earth terminals.

Internal earthing connections should be made to the Internal Earth terminal in the base of the housing using a ring crimp terminal to secure the earth conductor under the earth clamp. The earth conductor should be at least equal in size and rating to the incoming power conductors.

External earthing connections should be made to the M5 earth stud, using a ring crimp terminal to secure the earth conductor to the earth stud. The external earth conductor should be at least 4mm² in size.

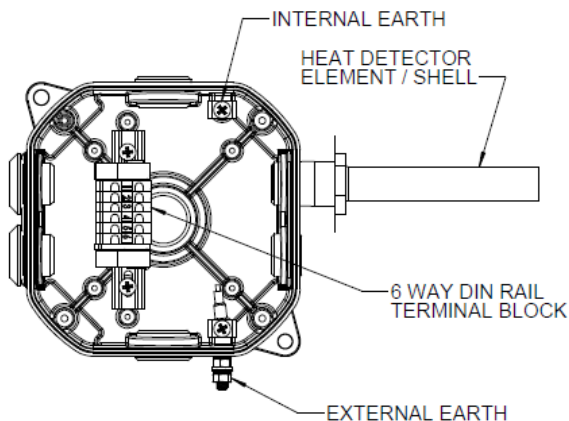

Figure 4: Earth Internal & External

9) Power Supply Selection

Electrical Ratings

Max Input Voltage/Current:

32Vac @ 50/60 Hz / 5.0A
32Vdc / 1A
24Vdc / 2A

When using EOL or Series monitoring devices voltage should be limited to 32Vdc max for monitoring via a panel.

See table 1

See section 12

Max Power Dissipation:

D2xH1-E 1.25W

10) Selection of Cable. Cable Glands, Blanking Elements & Adapters

ATEX/IECEX & UKEx Installations:

The equipment must only be installed by suitably qualified personnel in accordance with the latest issues of the relevant standards:

EN60079-14 / IEC60079-14: Explosive atmospheres - Electrical installations design, selection and erection
EN60079-10-1 / IEC60079-10-1: Explosive atmospheres - Classification of areas. Explosive gas atmospheres

The installation of the units must also be in accordance with any local codes that may apply and should only be carried out by a competent electrical engineer who has the necessary training.

The cable entries have 2-off M20 x 1.5 thread, 2-off ½" NPT thread & 1-off ¾" NPT thread

If a high IP (Ingress Protection) rating is required then a suitable sealing washer must be fitted under the cable glands or blanking plugs.

If the installation is made using cable glands, use suitably rated ATEX/IECEX/UKEx Ex ec ; tc certified IP66 cable glands (tightening torque 10Nm).

Any unused cable entries must be closed with suitably rated ATEX/IECEX/UKEx Ex ec ; tc certified IP66 blanking plugs (tightening torque 10Nm).

If the installation is made using conduit, openings must have a sealing fitting connected as close as practical to the wall of the enclosure, but in no case more than the size of the conduit or 50mm, whichever is the lesser.

NEC / CEC Installations:

The equipment must only be installed by suitably qualified personnel in accordance with the latest issues of the relevant standards:

The installation of the units must also be in accordance with any local codes that may apply and should only be carried out by a competent electrical engineer who has the necessary training.

The equipment must not be installed with any obstruction to the flanged flameproof joint any closer than permitted as per the NEC/CEC.

For high ambient temperatures the cable entry temperature may exceed +60°C or the cable branching point temperature may exceed 60°C and therefore suitable heat resisting cables and cable glands must be used, with a rated service temperature of at least the values stated below:

For model D2xH1-E:

Max. ambient temperature °C	40	45	50
req. Cable / Cable Gland rating: °C	60	65	70

The cable entries have 2-off M20 x 1.5 thread, 2-off ½" NPT thread & 1-off ¾" NPT thread

If a high IP (Ingress Protection) rating is required then a suitable sealing washer must be fitted under the cable glands or blanking plugs.

If the installation is made using cable glands, use suitably rated Ex ec ; tc certified IP66 cable glands and NEC/CEC installation standards (tightening torque 10Nm).

Any unused cable entries must be closed with suitably rated and Ex ec ; tc certified IP66 blanking plugs and NEC/CEC installation standards (tightening torque 10Nm).

All Installations:

If a high IP (Ingress Protection) rating is required then a suitable sealing washer must be fitted under the cable glands or blanking plugs. A minimum ingress protection rating of IP6X must be maintained for installations in explosive dust atmospheres.

The D2xH1 Heat Detector range can be supplied with the following types of adapters:
M20 to ½" NPT
M20 to ¾" NPT

It is important to note that stopping plugs cannot be fitted onto adapters, only directly onto the M20 entries.

Any other adapters used must be suitably rated and ATEX / IECEx / UKEx or NEC/CEC certified adapters.

11) Cable Connections

Electrical connections are to be made into the DIN-rail mounted inside the heat detector enclosure.

Electrical connections are to be made into the terminals, using solid wire 0.5-4mm² / AWG 20-12 or stranded wire, sizes 0.5-2.5mm² / AWG 24-14, and must be suitable for the terminal block type installed.

If fitting 2-off wires to one terminal way the sum of the 2-off wires must be a maximum cross-sectional area of 2.5mm². Strip wires to 8mm. Wires may also be fitted using ferrules.

Terminal screws need to be tightened down with a tightening torque :-

DIN Rail Terminals: 0.51 Nm / 4.5 Lb-in;

The DIN rail has a 6-way connection and allows for limited wiring of EOL and Series devices by customer, or, full pre-wired configurations if outlined with order to E2S.
For full wiring details see wiring diagrams D255-06-331

For EOL and Series device limitations and configurations see Section 12. Fitting can be requested by E2S at the order stage or added to the correct terminal blocks afterward. All devices must comply with the requirements stipulated in section 12.

When connecting wires to the terminals great care should be taken to dress the wires so that when the cover is inserted into the chamber the wires do not exert excess pressure on the terminal blocks. This is particularly important when using cables with large cross-sectional areas such as 2.5mm².

12) End-of-Line and Series Devices

The unit can be fitted with series / end-of-line monitoring resistors, monitoring diodes and zener diodes where power consumption is less than an EOL and/or series resistor option, if voltage is limited to 32Vdc max and limited to a maximum total power consumption no greater than 1.25W Max.

Min. device values and current limitations must be observed depending on supply voltage and type of components fitted. If a combination of resistors / diodes / zener diodes, values for all components must be observed and lowest current limit for either component becomes overall limit.

For example, if an end of line resistor is used it must have a minimum resistance value of 1k8 ohms and a minimum wattage of 0.5W, or a minimum resistance value of 470 ohms and a minimum wattage of 2W, for a 24Vdc supply voltage.

Type of component fitted	Supply voltage 24Vdc		Supply voltage 32Vdc	
	value	Max. current (mA)	value	Max. current (mA)
End-of-Line Resistor *See note	Suggested min. 470R/ 2W or min. 2k2/ 0.5W	2000	Suggested min. 1k8/ 2W or min. 3k3/ 0.5W	1000
End-of-Line Diode Type 1N5401	2W	59.13	2W	41.6
Series Resistor *See note	Suggested min. 470R/ 2W or min. 2k2/ 0.5W	2000	Suggested min. 1k8/ 2W or min. 3k3/ 0.5W	1000
Series Diode Type 1N5401	2W	59.13	2W	41.6
Series Zener Diode Type 1N5333B	3.3V	230	3.3V	230
	4.7V	162	4.7V	162
	5.1V	149	5.1V	149
	5.6V	136	5.6V	136
	6.2V	122	6.2V	122
	6.8V	112	6.8V	112
	10V	76	10V	76
	12V	63	12V	63

When fitting EOL or series device into the applicable terminal ensure the component leads are kept to a minimum and ensure the correct creepage and clearance is maintained as noted in the special conditions of safe use.

13) Heat Detector Option and Testing

The heat detector is available in the following temperature options.

Table 3 – Heat Detector Temperature Codes.

- (1) Response Time Index – Heat Detectors sensitivity and speed see EN54-5
- (2) Colour of detector shell marking band.

Functional Test

The functional test of the heat detector is a GO / No Go Test.

- Disconnect the unit from the system.
- Using a heat gun, or similar heat source, apply heat evenly to the complete heat detector element / shell. The heated air temperature must be above the alarm set point temperature of the unit.
- Using an ohm meter, see that the units internal contacts close when the set temperature is reached. Alternatively connect a 24Vdc bulb and power source in series with the detector to see if bulb light on activation.
- Remove the heat immediately after activation to prevent damage to the detector.
- Allow detector to cool to return to it initial open contact state, if the unit fails to return to the original state or activate replace unit.

Note :- The above test must only be performed if the appropriate steps have been taken to prevent unwarranted system activation/deactivation, or unwarranted discharge of an automatic fire extinguishing system. See note below.

HEAT DETECTOR WARNINGS

For an automatic fire extinguishing system, all releasing devices need to be physically disconnected from the release circuits of the control unit prior to any test. Refer to the automatic fire extinguishing systems maintenance manual for the appropriate steps to be taken to physically disconnect the releasing devices prior to testing the detector. Failure to take the necessary steps could result in an accidental discharge that could cause injury and property damage.

- DO NOT overshoot the set point of the unit by more than 100°F (55°C), this could result in a shift of the set point temperature.
- DO NOT contact the sensing shell with a heating device such as a soldering iron or blowtorch as this will damage the unit and cause a shift in the set point temperature.
- Keep the sensing shell of the unit free from Paint, grease and oil, etc. IF build up occurs, do not attempt to remove the buildup, Replace the unit.
- Detectors mounted in an area of physical abuse or damage must be protected without obstructing the thermal airpaths to the unit.
- Do not install the unit where the shell would be physically damaged by sand, grain, rock, etc.
- Any detector that has been involved in a fire or damaged must be replaced.

- Do not re-install or tighten detector element in junction box.

Note that any of the above could change the factory temperature settings, which may result in property damage and/or personal injury or death. It is possible for a unit to have been abused or damaged and not display any outwards indication of the damage. All units should be tested periodically in accordance with National Fire Protection Association Requirements (72e) or the Authority having local

Unit option code [t]	Setting Temperature	Spacings feet (meters)			RTI (1)	Colour Coding (2)
		UL	ULc	FM		
01	140°F / 60°C	50 (15)	50 (15)	25 (8)	Fast	Black
02	160°F / 71°C	25 (8)	25 (8)	25 (8)	Fast	Black
03	190°F / 88°C	50 (15)	50 (15)	25 (8)	Fast	White
04	210°F / 99°C	25 (8)	50 (15)	30 (9)	V- Fast	White
05	225°F / 107°C	25 (8)	50 (15)	30 (9)	V- Fast	White
06	275°F / 135°C	25 (8)	50 (15)	30 (9)	V- Fast	Blue
07	325°F / 163°C	50 (15)	50 (15)	30 (9)	V- Fast	Red
08	360°F / 182°C	25 (8)	50 (15)	30 (9)	V- Fast	Red
09	450°F / 232°C	25 (8)	50 (15)	30 (9)	V- Fast	Green
10	500°F / 260°C	50 (15)	50 (15)	30 (9)	V- Fast	Orange
11	600°F / 316°C	N/A	50 (15)	30 (9)	V- Fast	Orange
12	725°F / 385°C	N/A	50 (15)	30 (9)	V- Fast	Orange

jurisdiction.

14) Maintenance, Overhaul & Repair

Maintenance, repair and overhaul of the equipment should only be carried out by suitably qualified personnel in accordance with the current relevant standards:

For ATEX / IECEx / UKEx

EN60079-19/IEC60079-19 Explosive atmospheres - Equipment repair, overhaul and reclamation

EN60079-17/IEC60079-17 Explosive atmospheres - Electrical installations inspection and maintenance

Units must not be opened while an explosive atmosphere is present.

Units must not be opened while an explosive atmosphere is present.

If opening the unit during maintenance operations a clean environment must be maintained and any dust layer removed prior to opening the unit.

Repair of the flameproof threaded joints is not permitted.

Potential electrostatic charging hazard - Clean only with a damp cloth.

For NEC / CEC

UL 60079-19 Explosive atmospheres – Equipment repair, overhaul and reclamation

UL 60079-17 Explosive atmospheres – Electrical installations inspections and maintenance

Potential Electrostatic charging hazard – clean only with a damp cloth.

Units must not be opened while an explosive atmosphere is present.

To avoid a possible ELECTROSTATIC CHARGE the unit must only be cleaned with a damp cloth.

Units must not be opened while an explosive atmosphere is present.

Heat Detector for all installations

As part of the recommended maintenance procedure, perform a visual inspection of the D2xH1 Heat Detector in accordance with NFPA 72 guidelines, ensuring:-

- The heat detector element / shell is free of dents, dings or build up of foreign matter of any kind.
- If the shell is dented or shows signs of any physical damage, replace the unit immediately.
- If a build up of dust has accumulated on the unit, clean the unit with a clean damp cloth.
- If the detector element / shell has been painted, replace the unit. Note that some units are factory coated (set temperature identification band). Do not confuse these with units that were painted by the owners.

HEAT DETECTOR DEVICES

PRODUCTS:
D2xH1-E

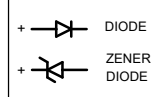

Module Device Codes		
	EOL	Series
Resistor	ExxxR	SxxxR
Diode	ED1	SD1
Zener Diode	ExxxZ	SxxxZ
LED	N/A	N/A

ISSUE	MOD No.	REASON - INITIAL - DATE
1		INTRODUCTION RNP 31-05-2024

HEAT DETECTOR	CONFIG. A1-1	HEAT DETECTOR WITH EOL DEVICE	CONFIG. A1-2	HEAT DETECTOR WITH SERIES DEVICES	CONFIG. A1-3	HEAT DETECTOR WITH EOL & SERIES DEVICES	CONFIG. A1-4	HEAT DETECTOR WITH EOL & ALT. SERIES DEVICES	CONFIG. A1-5
PRODUCT VERSION [v] [A] PRODUCT OPTION [o] [1] LED INDICATOR [u] [N]	Ex d Default N/A	PRODUCT VERSION [v] [A] PRODUCT OPTION [o] [1] LED INDICATOR [u] [N] SERIES MODULE [e] [Exxxx]	Ex d Default N/A EOL	PRODUCT VERSION [v] [A] PRODUCT OPTION [o] [1] LED INDICATOR [u] [N] SERIES MODULE [s] [Sxxxx]	Ex d Default N/A Series	PRODUCT VERSION [v] [A] PRODUCT OPTION [o] [1] LED INDICATOR [u] [N] MODULES [e][s] [Exxxx] [Sxxxx]	Ex d Default N/A EOL + Series	PRODUCT VERSION [v] [A] PRODUCT OPTION [o] [W] LED INDICATOR [u] [N] MODULE [e][s] [Exxxx] [Sxxxx]	Ex d Alt. EOL Pos'n. N/A EOL + Series

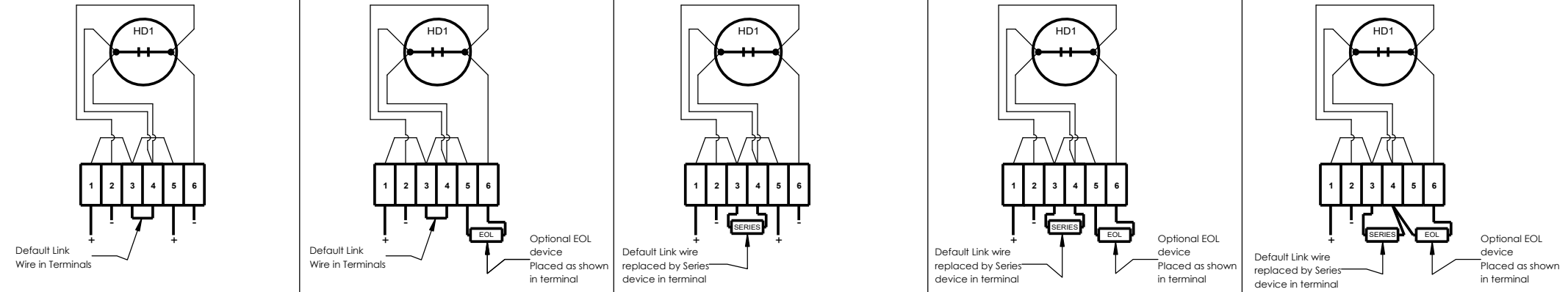
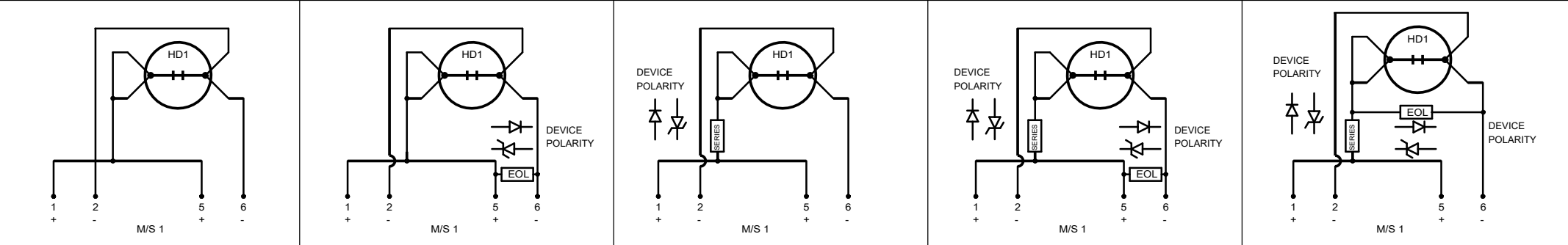

Circuit shown in Unoperated condition

Unoperated condition (Heat Detector in Standby Condition)
Terminals (+1,-2) & (+5,-6) open

Operated condition (Heat Detector in operated condition)
Terminals (+1,-2) & (+5,-6) closed

DRAWING TO BS8888:2000
GEOMETRIC TOLERANCES TO ISO1101:1983
LINEAR DIMENSIONAL TOLS
ANGULAR DIMENSIONAL TOLS

STANDARDS
D2xH1-E

DRAWN R.N.POTTS DATE 31-05-2024

CHECKED B.ISARD DATE 31-05-2024

APPROVED R.N.POTTS DATE 31-05-2024

SURFACE FINISH

WEIGHT (Kg)

MATERIAL

ALTERNATIVE MATERIAL

THIS DRAWING AND ANY INFORMATION OR DESCRIPTIVE MATTER THEREIN IS COMMUNICATED IN CONFIDENCE AND IS THE COPYRIGHT PROPERTY OF EUROPEAN SAFETY SYSTEMS LTD. NEITHER THE WHOLE OR ANY EXTRACT MAY BE DISCLOSED, LOANED, COPIED OR USED FOR MANUFACTURING OR TENDERING PURPOSES WITHOUT THEIR WRITTEN CONSENT.

EUROPEAN SAFETY SYSTEMS LTD.
AS PER LATEST DATE OF ISSUE SHOWN ABOVE

e2s warning signals

EUROPEAN SAFETY SYSTEMS LTD
IMPRESS HOUSE
MANSSELL ROAD
ACTON
LONDON W3 7QH
WWW.E2S.COM

ALL DIMENSIONS IN MM
IF IN DOUBT, ASK -
DO NOT SCALE

A3

TITLE
D2xH1-E Ex e HEAT DETECTOR WIRING / CIRCUIT
OPERATION DIAGRAM

SCALE NTS SHEET 1 OF 1 DRAWING NUMBER
D255-06-331

EU Declaration of Conformity



Manufacturer: European Safety Systems Ltd.
Impress House, Mansell Road, Acton
London, W3 7QH
United Kingdom

Authorised Representative: E2S Warnsignaltechnik UG
Charlottenstrasse 45-51
72764 Reutlingen
Germany

Equipment Type: D2xH1-E

Directive 2014/34/EU: Equipment and Protective Systems for use in Potentially Explosive Atmospheres (ATEX)

Notified Body for EU type Examination (Module B):	UL International Demko A/S Notified Body No.: 0539 Borupvang 5A, 2750 Ballerup, Denmark
EU-type Examination Certificate (Module B):	DEMKO 14 ATEX 4786493904X
Notified Body for Quality Assurance Notification / Conformity to EU-type based on quality assurance of the production process (Module D):	Sira Certification Service Notified Body No.: 2813 Unit 6, Hawarden Industrial Park, Hawarden, Deeside, CH5 3US, UK
Quality Assurance Notification (Module D):	SIRA 05 ATEX M342
Provisions fulfilled by the equipment:	II 2G Ex db ec IIC T6 Gc II 2D Ex tc IIIC T55°C C...110°C Dc
Standards applied:	EN IEC 60079-0:2018 EN 60079-1:2014 EN IEC 60079-7:2015 / A1:2017 EN60079-31:2014

Directive 2014/30/EU: Electromagnetic Compatibility Directive (EMC)

Standards applied:	EN 61000-6-1:2007 EN 61000-6-2:2005 EN 61000-6-3:2007 / A1:2011 / AC: 2012 EN 61000-6-4:2007 / A1: 2011
--------------------	--

Directive 2014/35/EU: Low Voltage Directive (LVD)

Standards applied:	EN 60947-1:2007 + A2:2014
--------------------	---------------------------

Directive 2011/65/EU: Restriction of the use of certain hazardous substances in electrical and electronic equipment (RoHS)

The product and all the components contained within it are in accordance with the restriction of the use of hazardous substances in electrical and electronic equipment, including amendment by Directive 2015/863/EU.

Regulation (EC) 1907/2006: Registration, Evaluation, Authorisation and Restriction of Chemicals (REACH)

The product and all the components contained within it are free from substances of very high concern.

Other Standards and Regulations

EN 60529:1992+A2:2013 - Degrees of protection provided by enclosures (IP code) – enclosure rated IP66/7

On behalf of European Safety Systems Ltd., I declare that, on the date the equipment accompanied by this declaration is placed on the market, the equipment conforms with all technical and regulatory requirements of the above listed directives, regulations and standards.

This Declaration is issued under the sole responsibility of the manufacturer.

A blue ink signature of Desmond Gayler, written in a cursive style.

Desmond Gayler
Quality Assurance Manager

Document No.: DC-125_Issue_A
Date and Place of Issue: London, 07/06/2024



UKCA Declaration of Conformity



Manufacturer: European Safety Systems Ltd.
 Impress House, Mansell Road, Acton
 London, W3 7QH
 United Kingdom

Equipment Type: D2xH1-E

Directive UKSI 2016:1107 (as amended by UKSI 2019:696) – Schedule 3A, Part 1 : Product or Protective System Intended for use in Potentially Explosive Atmospheres (UKCA)

Notified Body for UK type Examination (Module B):	UL International (UK) Ltd Notified Body No.: 0843 Unit 1-3 Horizon Kingsland Business Park, Wade Road, Basingstoke, Hampshire RG24 8AH UK
UK-type Examination Certificate (Module B):	UL21UKEX2130X
Notified Body for Quality Assurance Notification / Conformity to EU-type based on quality assurance of the production process (Module D):	Sira Certification Service Notified Body No.: 0518 Rake Lane, Eccleston, Chester CH4 9JN, UK
Quality Assurance Notification (Module D):	CSAE 22UKQAN0046
Provisions fulfilled by the equipment:	II 2G Ex db ec IIC T6 Gc II 2D Ex tc IIIC T55°C C...110°C Dc
Standards applied:	EN IEC 60079-0:2018 EN 60079-1:2014 EN IEC 60079-7:2015 / A1:2017 EN60079-31:2014

Directive 2014/30/EU: Electromagnetic Compatibility Directive (EMC)

Standards applied:	EN 61000-6-1:2007 EN 61000-6-2:2005 EN 61000-6-3:2007 / A1:2011 / AC: 2012 EN 61000-6-4:2007 / A1: 2011
--------------------	--

Directive 2014/35/EU: Low Voltage Directive (LVD)

Standards applied:	EN 60947-1:2007 + A2:2014
--------------------	---------------------------

Directive 2011/65/EU: Restriction of the use of certain hazardous substances in electrical and electronic equipment (RoHS)

The product and all the components contained within it are in accordance with the restriction of the use of hazardous substances in electrical and electronic equipment, including amendment by Directive 2015/863/EU.

Regulation (EC) 1907/2006: Registration, Evaluation, Authorisation and Restriction of Chemicals (REACH)

The product and all the components contained within it are free from substances of very high concern.

Other Standards and Regulations

EN 60529:1992+A2:2013 - Degrees of protection provided by enclosures (IP code) – enclosure rated IP66/7

On behalf of European Safety Systems Ltd., I declare that, on the date the equipment accompanied by this declaration is placed on the market, the equipment conforms with all technical and regulatory requirements of the above listed directives, regulations and standards.

This Declaration is issued under the sole responsibility of the manufacturer.

Desmond Gayler
 Quality Assurance Manager

Document No.: DC-133_Issue_A
 Date and Place of Issue: London, 07/06/2024