

1) Warnings



- DO NOT OPEN WHEN AN EXPLOSIVE ATMOSPHERE IS PRESENT
- DO NOT OPEN WHEN ENERGISED
- POTENTIAL ELECTROSTATIC CHARGING HAZARD - CLEAN ONLY WITH A DAMP CLOTH
- HIGH VOLTAGE SHOCK HAZARD. WAIT 5 MINUTES AFTER REMOVING POWER BEFORE OPENING THE ENCLOSURE
- DO NOT PAINT
- TO REDUCE THE RISK OF IGNITION OF HAZARDOUS ATMOSPHERES, CONDUIT RUNS MUST HAVE A SEALING FITTING CONNECTED WITHIN 18 INCHES OF ENCLOSURE
- TO PREVENT IGNITION OF GROUP A, B, C AND D ATMOSPHERES - SEE INSTRUCTION FOR CHEMICAL COMPATIBILITY

Avertissement:

- NE PAS OUVRIR UN PRESENCE D'ATMOSPHERE EXPLOSIVE
- NE PAS OUVRIR ENERGIE
- DANGER POTENTIEL CHARGE ÉLECTROSTATIQUE - NETTOYER UNIQUEMENT AVEC UN CHIFFON HUMIDE
- HAUT TENSION, RISK DE CHOC. ATTENDEZ 5 MINUTES APRES AVOIR DEBRANCHE L'ALIMENTATION AVANT D'OUVRIR LA BOITIER
- NE PAS PEINTURER
- POUR RÉDUIRE LE RISQUE D'INFLAMMATION DES ATMOSPHÈRES DANGEREUSES, LES CONDUITES DE CONDUIT DOIVENT AVOIR UN RACCORD D'ÉTANCHÉITÉ RACCORDÉ À MOINS DE 18 POUCHES DE L'ENFERMEMENT
- POUR PRÉVENIR L'INFLAMMATION DES ATMOSPHÈRES DES GROUPES A, B, C ET D-VOIR L'INSTRUCTION POUR LA COMPATIBILITÉ CHIMIQUE

2) Rating & Marking Information

2.1 Public Mode Fire Alarm Ratings

The D1xB2XH1 is certified for use as public mode visual alarm devices in accordance with UL1971 Third Edition and UL1638 Fifth Edition / CAN/ULC-S526 Fourth Edition.

The beacon must be set to one of the certified flash patterns of 1Hz, 1.33Hz or 1.5Hz (for DIP switch settings see section 10). For light output ratings see section 11.

2.2 NEC & CEC Class / Division Ratings for US / Canada

The D1xB2XH1 Xenon beacon complies with the following standards:

Type Approval Standards:

UL 1203
CSA C22.2 No. 30-M1986
CSA C22.2 No. 25-1966
UL1638 & UL1971
CAN/ULC S526

The D1xB2XH1 10J Xenon Beacon is rated as follows:

Class / Division Ratings for US and Canada (NEC & CEC)

Class I Div 1 Group ABCD T5 Ta -55°C to +80°C
Class I Div 1 Group ABCD T6 Ta -55°C to +60°C
Class II Div 1 Group EFG T4A Ta -55°C to +80°C
Class II Div 1 Group EFG T5 Ta -55°C to +65°C
Class II Div 1 Group EFG T6 Ta -55°C to +50°C
Class III Div 1 Ta -55°C to +80°C

Class / Zone ratings for US (NEC)

Class I Zone 1 AEx db IIC T5 Ta -55°C to +80°C
Class I Zone 1 AEx db IIC T6 Ta -55°C to +60°C
Zone 21 AEx tb IIIC 107°C Ta -55°C to +80°C

Class / Zone ratings for Canada (CEC)

Ex db IIC T5 Ta -55°C to +80°C
Ex db IIC T6 Ta -55°C to +60°C
Ex tb IIIC 107°C Ta -55°C to +80°C

The certification approval has validated continuous use up to 38°C ambient and also for transient use up to 80°C ambient. The test standards UL1638 and UL1638A require approved devices to operate continuously in an ambient of 25°C. The E2S range of D1xB2 strobe beacons comply with this test. Additionally, the D1xB2 range have been tested at an elevated temperatures continuously in ambient temperatures of 38°C. Continuous use is defined as a state of in which the device is powered permanently, at all times, without any off period. Transient use is defined as a state in which the device is activated by the safety system and remains powered whilst the alarm condition exists. The D1xB2 range has been UL approved for use in environments from -55°C to +80°C.

Installation must be carried out in compliance with the National Electric Code / Canadian Electric Code

2.6 Ingress Protection Ratings

The product is rated for ingress Protection as follows:

IP rating per EN60529: IP66

Type rating per UL50E / NEMA250: 4 / 4X / 3R / 13

To maintain the ingress protection rating, the cable entries must be fitted with suitably rated, certified cable entry and/or blanking devices during installation.

2.7 Electrical Ratings

Model No.	Voltage Range
D2xB1XH1	20-28Vdc

Table 1: Electrical Ratings

It is important that a suitable power supply is used to run the equipment. The power supply selected must have the necessary capacity to provide the input current to all the units.

The input current will vary according to the voltage input level.

For detailed max and surge current ratings of the device please see Section 12.

3) Special Conditions of Use

To maintain the ingress protection rating and mode of protection, the cable entries must be fitted with suitably rated cable entry and/or blanking devices during installation. If conduit is used for installation, seal conduit within 18 inches from the enclosure.

If entries are fitted with adaptors they must be suitably rated for the application. Fitting of blanking elements into adaptors is not permitted.

Installation

There are no restrictions on unit orientation.

Safe Installation Requirements

Check that the 'O' ring seal is in place before replacing the explosionproof cover.

4) Location and Mounting

The location of the beacon should be made with due regard to the area over which the warning signal must be visible. It should only be fixed to services that can carry the weight of the unit.

The D1xB2XH1 beacon can be mounted using one of three methods.

1. The beacon can be surface mounted by removing, rotating and reinstalling the stowed mounting lugs. These are suitable for 6mm diameter fixings.

- a. Remove 2 x M5 fasteners per mounting lug
- b. Reverse and rotate lug and reseat onto enclosure
- c. Secure lug using the 2 x M5 fasteners

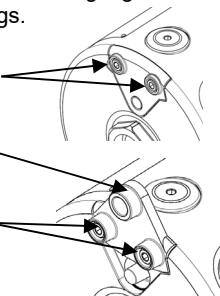

2. Alternatively the beacon can be conduit mounted using the 3/4" NPT entry on the base of the unit.

3. Additionally, the beacon can be mounted using the ratchet adjustable stainless-steel wall bracket assembly. This is available as an accessory – part code: SP77-0001.

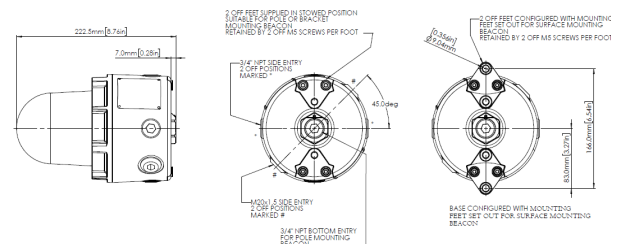

Fig. 1 Fixing Location for Public Mode Beacon

5) Access to the Enclosure



Warning – High voltage may be present, risk of electric shock. DO NOT open when energised, disconnect power before opening.



Warning – Hot surfaces. External surfaces and internal components may be hot after operation, take care when handling the equipment.

In order to connect the electrical supply cables to the beacon, it is necessary to open the explosion proof enclosure. Remove the glass dome cover assembly to gain access to the chamber. This can be achieved by unscrewing the glass dome cover, taking extreme care not to damage the threads when doing so.

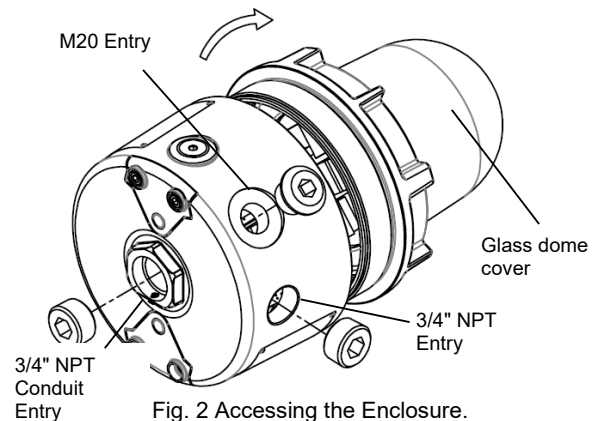

Fig. 2 Accessing the Enclosure.

On completion of the cable wiring installation the threads should be inspected to ensure that they are clean and that they have not been damaged during installation. Also check that the 'O' ring seal is in place, on the thread diameter and in contact with the flat face of the glass dome cover casting. When replacing the glass dome cover assembly ensure it is tightened fully.

6) Selection of Cable, Cable Glands, Blanking Elements & Adapters

When selecting the cable size, consideration must be given to the input current that each unit draws (see section 12), the number of beacons on the line and the length of the cable runs. The cable size selected must have the necessary capacity to provide the input current to all of the beacons connected to the line.

When selecting the cable size consideration must be given to the voltage drop over the length of the cable run to ensure the min. input voltage at the point of use (voltage range, see section 12)

The voltage drop depends on:

- The total current draw of the devices installed on this cable run
- The wire size and total length of the cable run, determining the total resistance of this cable run
- The minimum output voltage supplied by the power supply

The voltage drop and input voltage at the point of use can be calculated as follows:

Total Wire resistance =
Wire resistance / 1000ft x length of cable run x 2

(length of cable run needs to be multiplied by two to account for two wires going to and from the unit)

Total current draw =
Current draw per unit x number of units

Voltage Drop = Total current draw x Total wire resistance

Minimum output of power supply =
Min. voltage at point of use + voltage drop

The entries are 2-off M20 x 1.5 thread, 2-off ½" NPT thread & 1-off ¼" NPT thread

For ambient temperatures over +45°C the cable entry temperature may exceed +70°C. Therefore suitable heat resisting cables and cable glands, rated to min. 75°C must be used.

If a high IP (Ingress Protection) rating is required then a suitable sealing washer must be fitted under the cable glands or blanking plugs.

For use in explosive dust atmospheres, a minimum ingress protection rating of IP6X must be maintained.

For use in explosive gas atmospheres, a minimum ingress protection rating of IP54 must be maintained.

NPT plugs should be greased before insertion.

7) Cable Connections

Electrical Connections are to be made into the terminal blocks using solid or stranded wire, sizes 0.5-2.5mm² / AWG 20-14. Wire insulation needs to be stripped 6-7mm. Wires may be fitted securely with crimped ferrules. Terminal screws

need to be tightened down with a tightening torque of 0.4 Nm / 3.5 Lb-in.

See section 5 of this manual for access to the enclosure.

8) Wiring

4-way terminal block is provided on the beacons for power. There are 2-off +ve, 2-off -ve terminal and an internal Earth boss. Refer to wiring diagram: D191-06-251.

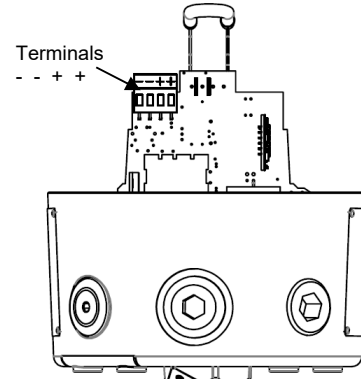

Fig. 3 D1xB2XH1 Terminals

8.1 Line Monitoring

On the D2xB1XH1 unit, DC reverse line monitoring can be used if required.

All DC beacons have a blocking diode fitted in their supply input lines. An end of line monitoring resistor can be connected across the +ve and -ve terminals in the explosion proof enclosure. If an end of line resistor is used it must have the following values:

Minimum resistance 3K3 Ohms	Minimum Power 0.5W
Minimum resistance 500 Ohms	Minimum Power 2.0W

The resistor must be connected directly across the +ve and -ve terminals as shown in the following drawing. Form the resistor legs as shown in Fig. 5a, fit the resistor across the two terminals, as shown in Fig. 5b.

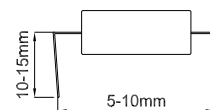

Fig. 4a End of Line Resistor Forming

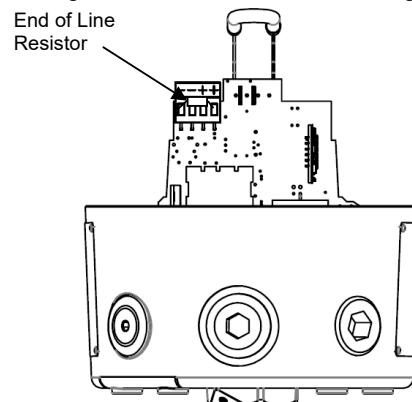

Fig. 4b End of Line Resistor Placement

9) Earthing

The unit has an internal earth terminal, (please see fig 6).

Internal earth connections should be made to the M4 earth screw, using a ring crimp terminal to secure the earth conductor to the earth screw.

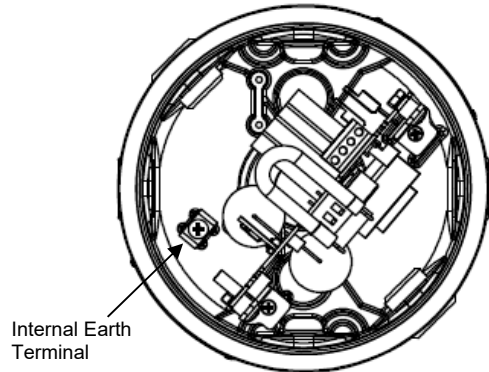

Fig. 5: Internal Earth Location

10) Settings

10.1 Flash Rate Setting



Warning – high-intensity light source. Avoid looking directly at the light source for extended periods of time.

The D1xB2XH1 beacon can produce different flash patterns as shown in Table 1. The flash patterns are selected by operation of the flash setting DIP switch on the PCB, Fig 7.

Note Only 1Hz ; 1.5Hz & 1.33Hz flash rate are Public Mode Fire approved

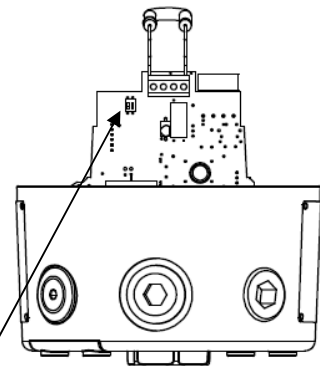

Fig. 6a: DIP Switch Location

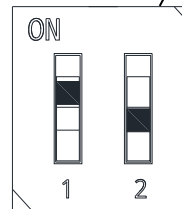

Fig. 6b Dip Switch

1=ON; 0=OFF

Example shown: 10 = Flashing 1.5Hz
(Default setting is 00 1Hz)

Switch Setting	S1 Mode
00	1Hz* (60FPM)
01	1.33Hz* (80FPM)
10	1.5Hz* (90FPM)
11	Double Flash

(*setting permitted for use as public mode fire alarm device)

Table 2: Switch Positions for Flash Patterns

11) Light output for Fire alarm use

In order to meet the requirements for UL 1971 & UL1638 for Public Mode Fire alarm use when used with 1Hz (60FPM), 1.5Hz (90FPM) & 1.33Hz (80FPM) the installation must be carried out to the correct NFPA standards and guidelines or CEC regulations.

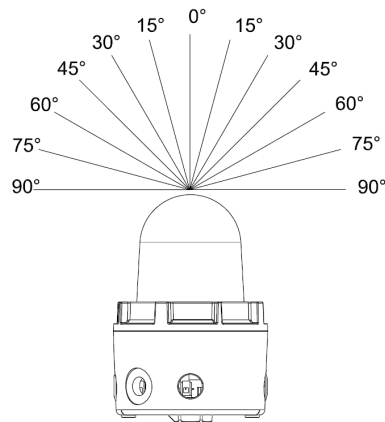

11.1 Horizontal Light Output Dispersion for wall mounting – public mode

Fig. 7 – Horizontal dispersion angles for wall mounting

Table 3A - D1xB2XH1 - Horizontal Light Output Dispersion for Wall Mounting				
Viewing Angle	% Of Rating	Intensity (cd) at 1Hz flash rate (60FPM)	Intensity (cd) at 1.5Hz flash rate (90FPM)	Intensity (cd) at 1.33Hz flash rate (80FPM)
0°	100	86.37	51.65	58.57
5-25°	90	77.73	46.49	52.71
30-45°	75	64.78	38.74	43.93
50°	55	47.50	28.41	32.21
55°	45	38.87	23.24	26.36
60°	40	34.55	20.66	23.43
65°	35	30.23	18.08	20.50
70°	35	30.23	18.08	20.50
75°	30	25.91	15.50	17.57
80°	30	25.91	15.50	17.57
85°	25	21.59	12.91	14.64
90°	25	21.59	12.91	14.64
Compound 45° to Right	24	20.73	12.40	14.06
Compound 45° to Left	24	20.73	12.40	14.06

11.2 Vertical Light Output Dispersion for wall mounting – public mode

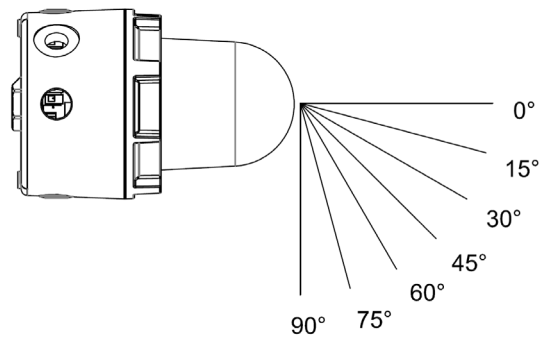

Fig. 8 – Vertical dispersion angles for wall mounting

Table 4A - D1xB2XH1 - Vertical Light Output Dispersion for Wall Mounting				
Viewing Angle	% Of Rating	Intensity (cd) at 1Hz flash rate (60FPM)	Intensity (cd) at 1.5Hz flash rate (90FPM)	Intensity (cd) at 1.33Hz flash rate (80FPM)
0°	100	86.37	51.65	58.57
5-30°	90	77.73	46.49	52.71
35°	65	56.14	33.57	38.07
40°	46	39.73	23.76	26.94
45°	34	29.37	17.56	19.91
50°	27	23.32	13.95	15.81
55°	22	19.00	11.36	12.89
60°	18	15.55	9.30	10.54
65°	16	13.82	8.26	9.37
70°	15	12.96	7.75	8.79
75°	13	11.23	6.71	7.61
80-90°	12	10.36	6.20	7.03

11.3 Vertical Light Output Dispersion for ceiling mounting – public mode

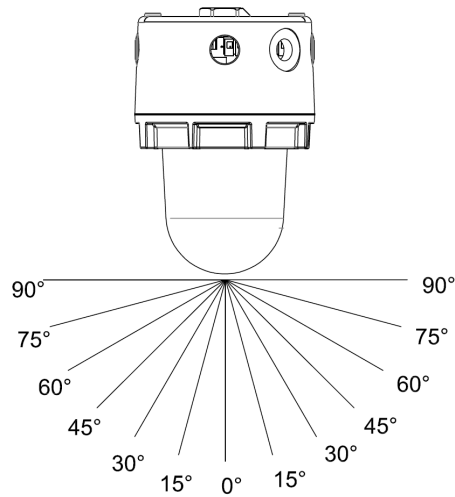

Fig. 9 – Vertical dispersion angles for ceiling mounting X and Y planes

Table 5A - D1xB2XH1 - Vertical Light Output Dispersion for Ceiling Mounting				
Viewing Angle	% Of Rating	Intensity (cd) at 1Hz flash rate (60FPM)	Intensity (cd) at 1.5Hz flash rate (90FPM)	Intensity (cd) at 1.33Hz flash rate (80FPM)
0°	100	86.37	51.65	58.57
5-25°	90	77.73	46.49	52.71
30-45°	75	64.78	38.74	43.93
50°	55	47.50	28.41	32.21
55°	45	38.87	23.24	26.36
60°	40	34.55	20.66	23.43
65°	35	30.23	18.08	20.50
70°	35	30.23	18.08	20.50
75°	30	25.91	15.50	17.57
80°	30	25.91	15.50	17.57
85°	25	21.59	12.91	14.64
90°	25	21.59	12.91	14.64

All light output ratings min. values as per UL 1971 / UL1638 / CAN/ULC-S526 at worst-case (min.) input voltage.

12) Electrical Ratings

12.1 Operating current Consumption

Table 6 - Electrical Ratings					
Model	Nom. Voltage	Voltage Range	Flash Rate Setting	Nom. operating current [#]	Max. operating current ^{##}
D1xB2XH1DC024	24Vdc	20-28Vdc	1Hz (60fpm)*	635 mA	765 mA
			1.5Hz (90fpm)*	700 mA	765 mA
			1.33Hz (80fpm)*	695 mA	765 mA
			Double flash	580 mA	765 mA

* Flash rates Public Mode Fire

nominal rms current at nominal voltage

max. rms current at worst-case voltage in voltage range.

12.2 Surge current for Fire Alarm system use per UL Listing

Surge Currents					
Model	Nom. Voltage	Voltage Range	Flash Rate Setting	Init. Peak Surge Current (A)	Init. RMS Surge Current (mA)
D1xB2XH1DC024	24Vdc	20-28Vdc	1Hz (60fpm)	1150 mA	697 mA
			1.5Hz (90fpm)	1100 mA	742 mA
			1.33Hz (80fpm)	1090 mA	680 mA
			Double flash	1070 mA	639 mA

Surge current given at worst case voltage

ISSUE	MOD No.	REASON - INITIAL - DATE
A	ACN0162	INTRODUCTION RSR 06/01/2025

A

B DC XENON D1xB2XH1 & D1xB2XH2 UNITS
Line Monitoring
Power: +ve & -ve

OPTIONAL LINE MONITORING RESISTOR, CUSTOMER SUPPLIED,
 RECOMMENDED MINIMUM VALUES:
 500Ω MIN, 2W MIN OR 3K3Ω MIN, 0.5W MIN

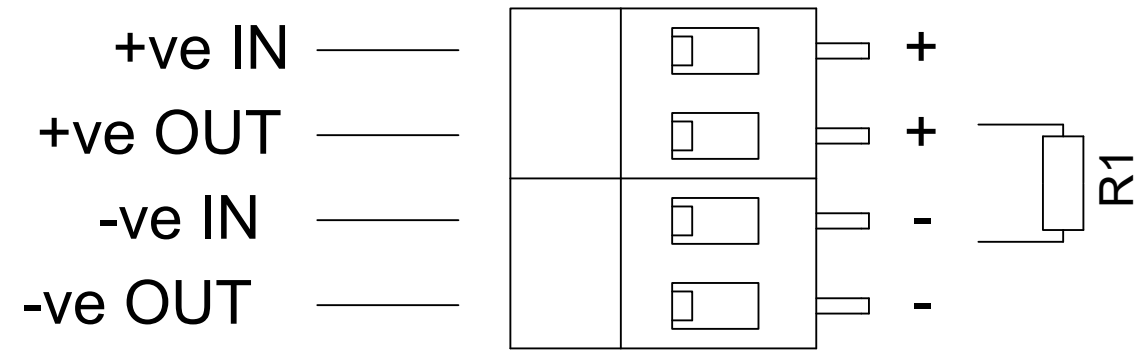
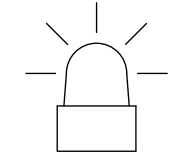

C

D

E

F

DRAWING TO BS8888:2000 GEOMETRIC TOLERANCES TO ISO1101:1983 LINEAR DIMENSIONAL TOLS ANGULAR DIMENSIONAL TOLS	DRAWN	DATE	SURFACE FINISH	WEIGHT (Kg)	THIS DRAWING AND ANY INFORMATION OR DESCRIPTIVE MATTER THEREIN IS COMMUNICATED IN CONFIDENCE AND IS THE COPYRIGHT PROPERTY OF EUROPEAN SAFETY SYSTEMS LTD. NEITHER THE WHOLE OR ANY EXTRACT MAY BE DISCLOSED, LOANED, COPIED OR USED FOR MANUFACTURING OR TENDERING PURPOSES WITHOUT THEIR WRITTEN CONSENT. © EUROPEAN SAFETY SYSTEMS LTD. AS PER LATEST DATE OF ISSUE SHOWN ABOVE	EUROPEAN SAFETY SYSTEMS LTD IMPRESS HOUSE MANSELL ROAD ACTON LONDON W3 7QH WWW.E2S.COM	ALL DIMENSIONS IN MM		A3		
	R.S.RAIT	06/01/2025					MATERIAL	TITLE D1xB2XH1 & D1xB2XH2 BEACON WIRING DIAGRAM			
	CHECKED	DATE					ALTERNATIVE MATERIAL	SCALE	SHEET	DRAWING NUMBER	
STANDARDS	R.N.POTTS	06/01/2025				NTS	1 OF 1	D190-06-251			
D1xB2XH BEACONS	APPROVED	DATE									
	R.N.POTTS	06/01/2025									

G

EU Declaration of Conformity



Manufacturer: European Safety Systems Ltd.
Impress House, Mansell Road, Acton
London, W3 7QH
United Kingdom

Authorised Representative: E2S Warnsignaltechnik UG
Charlottenstrasse 45-51
72764 Reutlingen
Germany

Equipment Type: D1xS1, D1xS2
D1xL1, D1xL2
D1xC1X05, D1xC1X10, D1xC2X05, D1xC2X10
D1xB2XH1, D1xB2XH2

Directive 2014/34/EU: Equipment and Protective Systems for use in Potentially Explosive Atmospheres (ATEX) - D1xS1, D1xS2, D1xL1, D1xL2, D1xC1X05, D1xC1X10, D1xC2X05 and D1xC2X10 only

Notified Body for EU type Examination (Module B):	UL International Demko A/S Borupvang 5A 2750 Ballerup Denmark
EU-type Examination Certificate (Module B):	DEMKO 19 ATEX 2141X
Notified Body for Quality Assurance Notification / Conformity to EU-type based on quality assurance of the production process (Module D):	Sira Certification Service Notified Body No.: 2813 Unit 6, Hawarden Industrial Park, Hawarden, Deeside, CH5 3US, UK
Quality Assurance Notification (Module D):	SIRA 05 ATEX M342
Provisions fulfilled by the equipment:	II 2G Ex db IIC T6...T3 GB II 2D Ex tb IIIC T82°C...145°C Db
Standards applied:	EN 60079-0:2018 EN 60079-1:2014 EN60079-31:2014

Regulation EU No. 305/2011: Construction Products Regulation (CPR) – D1xS1FDC024***A1R & D1xS1FDC024***A1G only – tones 1, 2, 5, 8, 40, 44, 53 only

Notified Product Certification Body for Certificate of Constancy of Performance or EC Type Examination Certificate and continuous surveillance, assessment and evaluation of factory production control:	BRE Global Assurance (Ireland) Limited Notified Body No.: 2831 DCU Alpha, Old Finglas Road, Glasnevin, Dublin, D11 KXN4
Certificate of Constancy of Performance or EC Type Examination Certificate:	2831-CPR-F4858
Standards applied:	EN 54-3:2001 + A1:2002 + A2:2006

Directive 2014/90/EU: Marine Equipment Directive (MED) – part codes specified below only - D1xS1FDC024***A1R & D1xS1FDC024***A1G only

Notified Body for EU type Examination (Module B) and Conformity to EU-type based on quality assurance of the production process (Module D):	DNV AS Notified Body No.: 0575 DNV Høvik, Norway
EU-Certificate Type Examination (Module B):	MEDB000085K
EU Certificate of Conformity for the Quality Assurance System (Module D):	MEDD00000GV
Standards applied:	EN 54-3:2014 incl. A1: 2019 IEC 60092-504: 2016 IEC 60533: 2015

EU Declaration of Conformity



Directive 2014/30/EU: Electromagnetic Compatibility Directive (EMC)

Standards applied:

EN 61000-6-1:2007
EN 61000-6-2:2005
EN 61000-6-3:2007 / A1:2011 / AC: 2012
EN 61000-6-4:2007 / A1: 2011

Directive 2014/35/EU: Low Voltage Directive (LVD)

Standards applied:

EN 60947-1:2007 + A2:2014

Directive 2011/65/EU: Restriction of the use of certain hazardous substances in electrical and electronic equipment (RoHS)

The product and all the components contained within it are in accordance with the restriction of the use of hazardous substances in electrical and electronic equipment, including amendment by Directive 2015/863/EU.

Regulation (EC) 1907/2006: Registration, Evaluation, Authorisation and Restriction of Chemicals (REACH)

The product and all the components contained within it are free from substances of very high concern.

Other Standards and Regulations

EN 60529:1992+A2:2013 - Degrees of protection provided by enclosures (IP code) – enclosure rated IP66/67

On behalf of European Safety Systems Ltd., I declare that, on the date the equipment accompanied by this declaration is placed on the market, the equipment conforms with all technical and regulatory requirements of the above listed directives, regulations and standards.

This Declaration is issued under the sole responsibility of the manufacturer.

A handwritten signature in blue ink, appearing to read 'Desmond Gayler'.

Desmond Gayler
Quality Assurance Manager

Document No.: DC-067_Issue_K
Date and Place of Issue: London, 18/03/2024