

### 1) Certification & Ratings

All units have a rating label, which carries the following important information: -

**Model No.:** WP7-PB-S (Single Switch)  
WP7-PB-D (Dual Switch)

WP7-PM-S (Single Switch)  
WP7-PM-D (Dual Switch)

WP7-PT-S (Single Switch)  
WP7-PT-D (Dual Switch)

CE Marking 

UKCA Marking 

**IP Rating:** IP66/67 to EN/IEC60529

**Ambient Temperature Range:** -55°C to +75°C

### 2) Location and Mounting

The location of the call point should enable ease of access for operation and testing. The unit should be mounted using the 4 off fixing holes which will accept up to M5 sized fixings. They should only be fixed to services that can carry the weight of the unit.

To gain access to the mounting holes in the base the front cover must be removed. See Section 3.

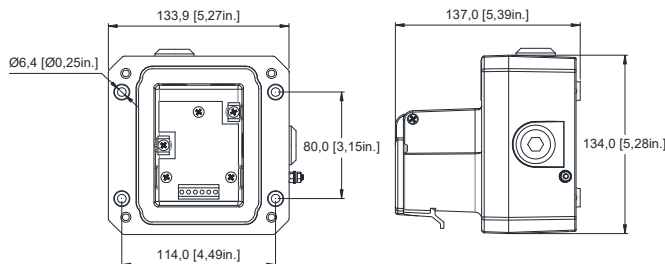

Fig. 1 View of base unit showing fixing centres (in mm).

### 3) Access to the Enclosure



Warning – High voltage may be present, risk of electric shock. DO NOT open when energised, disconnect power before opening.

To access the chamber, remove the four off M6 x 50 stainless steel cap head cover bolts

Once the screws are removed the cover will hang down out of the way to gain access to the terminals, the internal earth terminal and mounting hole recesses.

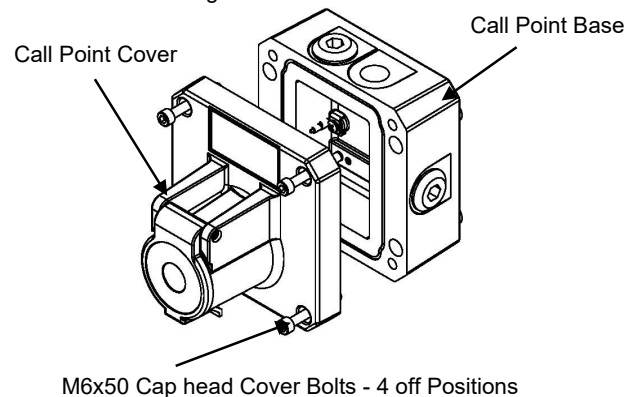

Fig. 2 Accessing the Explosion proof Enclosure.

Check that the earth bonding wire between the two castings is secure and the 'O' ring seal is in place.

### 4) Earthing

The units are provided with internal and external earth terminals which are mounted in the base of the unit.

Internal earthing connections should be made to the Internal Earth terminal in the base of the housing using a ring crimp terminal to secure the earth conductor under the earth clamp. The earth conductor should be at least equal in size and rating to the incoming power conductors.

When using the internal earth terminal ensure that the stainless steel M4 flat washer is between the incoming earth wire and the enclosure.

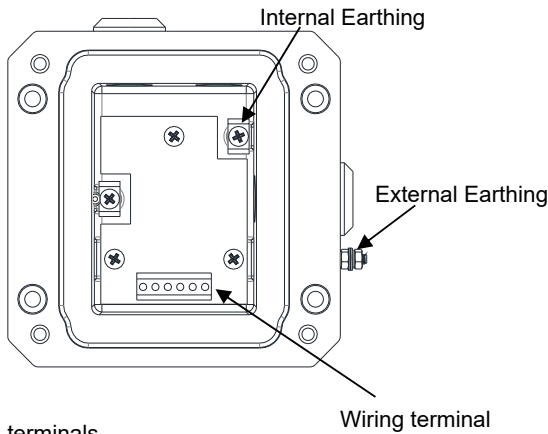

Fig 3 Earth terminals

## 5) Power Supply Selection

### Electrical Ratings

Input Voltage:

AC voltage 250V Max Current 5.0A Max  
 DC voltage 75V Max Current 0.75A Max  
 DC voltage 50V Max Current 1.0A Max  
 DC voltage 30V Max Current 5.0A Max Resistive Load;  
 Inductive Load 3.0A Max  
 DC voltage 12V Max Current 5.0A Max

Electrical connections are to be made into the terminal blocks / DIN rail provided. See Section 8 for wiring options.

## 6) Selection of Cable. Cable Glands, Blanking Elements & Adapters

The cable gland entries have an M20 x 1.5 entry thread.

The WP7 Call Point range can be supplied with the following types of adapters:

M20 to 1/2" NPT  
 M20 to 3/4" NPT  
 M20 to M25

## 7) Cable Connections

Electrical Connections are to be made into the terminal blocks using solid or stranded wire. See section 3 of this manual for access to the enclosure.

Wires having a cross sectional area between 0.5 mm<sup>2</sup> to 2.5mm<sup>2</sup> (AWG 20 – 14) can be connected to each terminal way.

If an input and output wire is required the 2-off Live/Neutral or +/- terminals can be used. If fitting 2-off wires to one terminal way the sum of the 2-off wires must be a maximum cross sectional area of 2.5mm<sup>2</sup>.

Strip wires to 8mm. Wires may also be fitted using ferrules.

Terminal screws need to be tightened down with a tightening torque of 0.45 Nm / 5 Lb-in.

When connecting wires to the terminals great care should be taken to dress the wires so that when the cover is inserted into the chamber the wires do not exert excess pressure on

the terminal blocks. This is particularly important when using cables with large cross sectional areas such as 2.5mm<sup>2</sup>.

## 8) Wiring Unit

The units come with two options.

A DIN rail version which has 8-way connection and allows for limited wiring of EOL devices by customer, or, full pre-wired configurations if outlined with order to E2S.

For full wiring details see wiring diagrams D202-06-211

The PCB Terminal Version has a 6-way connector but is designed to allow for full customer configuration with Series and EOL devices in a number of wiring configurations.

For full wiring details see wiring diagrams D202-06-212

For EOL and Series device limitations and configurations see Section 9. Fitting can be requested by E2S at the order stage or added to the correct terminal blocks afterward. All devices must comply with the requirements stipulated in section 9.

### Wiring Connections for 8-Way DIN Rail

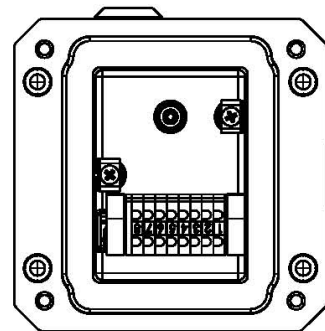

Fig. 4 DIN Rail in Base

### Wiring Connections For 6-Way PCB Terminal Board

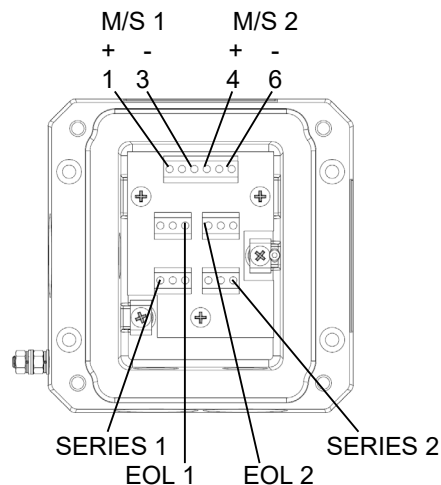

Fig. 5 PCB Terminal Block in Base

## 9) End-of-Line and Series Devices

All models can be fitted with series resistors, end-of-line monitoring resistors, monitoring diodes, zener diodes and also specific customer modules if supplied with direct current up to 50Vdc.

The following table 1 shows limitations for all possible variations:

Type of component fitted	Suggested EOL/ Series Device Type Value
End-of-Line Resistor	330Ω Suggested Min.
End-of-Line Diode Type 1N5401	2W
Series Resistor	330Ω Suggested Min.
Series Zener Diode Type 1N5333B Suggested Sizes	3.3V
	4.7V
	5.1V
	5.6V
	6.2V
	6.8V
	10V
	12V

EOL (End of line) device;

- resistor – ExxxR
- diode – ED1
- zener – ExxxZ

Series (In line) device;

- resistor – SxxxR
- diode – SD1
- zener – SxxxZ
- LED

Microswitch 1 = M/S 1  
Microswitch 2 = M/S 2

The unit can be wired with a maximum of 4 module devices. Please refer to wiring schematic D202-06-211 or D202-06-211

When customer is fitting EOL or Series device ensure device leads are insulated or routed so not to create an electrical short.

An optional Ex d LED monitoring module is designated after the model no as either, GNExCP7-PT-S-L or GNExCP7-PT-D-L to include an LED and power limiting resistor or, GNExCP7-PT-S-C or GNExCP7-PT-D-C with includes the LED but where the units current must be limited to 20mA.

The optional Ex d LED monitoring module is fitted in the M20 side entry as shown, when the main M20 entries are at the bottom of unit. The wiring is shown as per wiring diagram. D202-06-211 & D202-06-212 see the various LED configuration options.

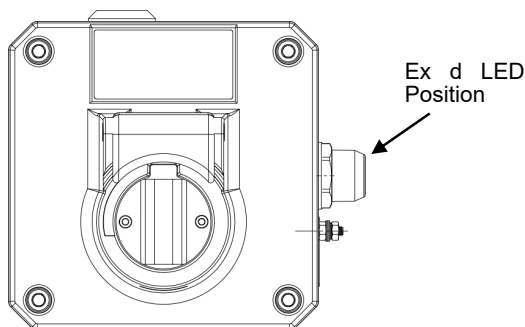

## 10) Testing unit operation

The push button types -PB -PT and -PM are all operated by pressing in the main plunger down activating the switch.

The -PB plunger needs to be firstly twisted by 90 degrees clockwise to position shown and then pressed in.

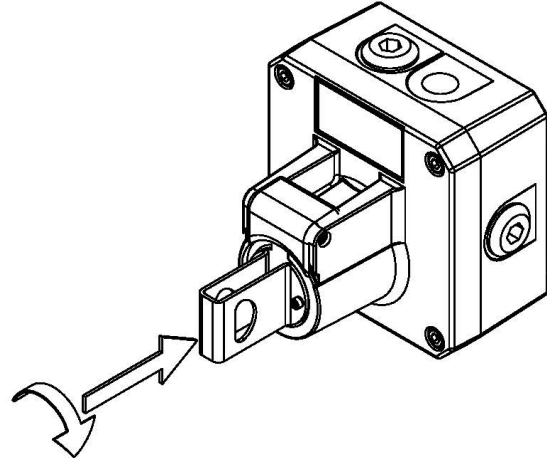

Fig 6 -PB Version Twist and Push Action

The -PM and -PT need to have the protective flip lid opened first and then the main plunger pressed in.

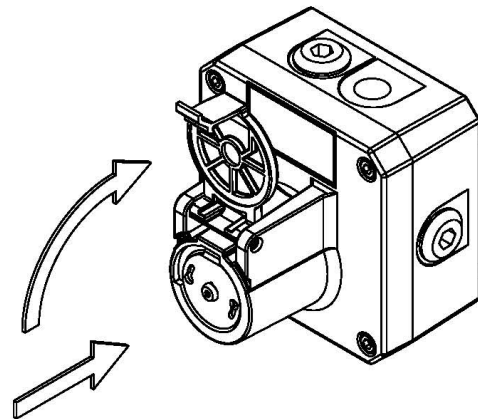
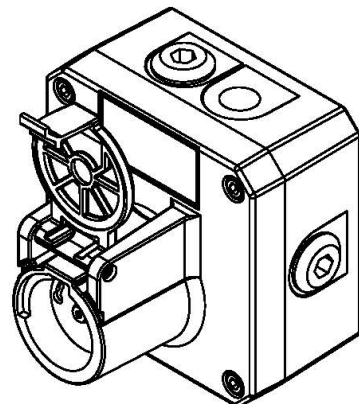

Fig 7 -PT & -PM Versions Push Action

On -PM versions the operation is momentary and as such the plunger will reset automatically once the pressure on the plunger is released.



On -PB the plunger will remain in the down position until the unit is reset. This is done by pulling the plunger back up to the start position shown in fig 6. Then the plunger is twisted back 90 degrees anti-clockwise to the stop.

On -PT the plunger will remain in the down position until the unit is reset. This is done by lifting the plunger back up using the tool reset key provided.

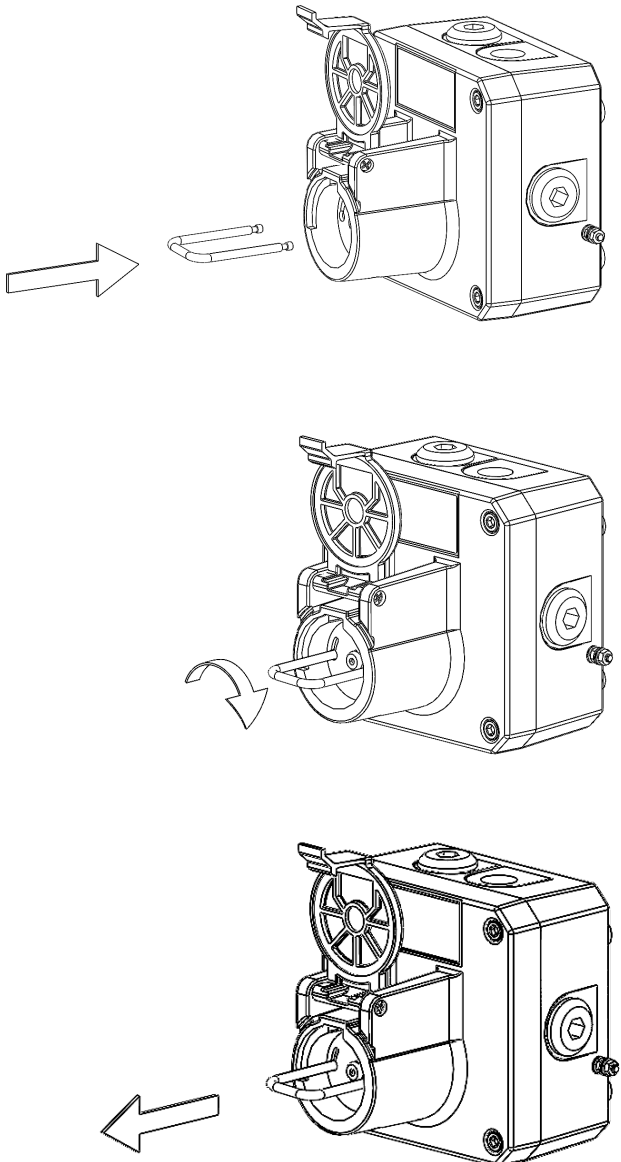

**SINGLE MICROSWITCH DEVICES**

**SHEET 1**

**Module Device Codes**

ISSUE	MOD No.	REASON - INITIAL - DATE
7	ACN0178	Correction to LED wiring in option W RNP 15-04-2025
8	ACN0187	LED put on N/C side of circuit, note on LED LD1 detailed RNP 28-05-2025

Diagram	Sheet
Dual Switch Wiring Configurations	2,3,5,6,7,8
LED Indicator Wiring Configurations	4,5,6,8
Parallel Dual Switch Wiring Configurations	7, 8

GNEXCP7-BG[s][t][l][e][m][d][v][o][x][u]-[e][s]  
 Switch Type [s] Product Version [v] LED Indicator [u] Series Module [s]  
 Terminals [t] Product Option [o] EOL Module [e]

	EOL	Series
Resistor	ExxxR	SxxxR
Diode	ED1	SD1
Zener Diode	ExxxZ	SxxxZ
LED	N/A	L or C

SINGLE SWITCH	CONFIG. D1-1	SINGLE SWITCH WITH SERIES DEVICE	CONFIG. D1-2	SINGLE SWITCH WITH EOL & SERIES DEVICES	CONFIG. D1-3	SINGLE SWITCH WITH EOL & ALT. SERIES DEVICES	CONFIG. D1-4
---------------	--------------	----------------------------------	--------------	---	--------------	--	--------------

SWITCH TYPE [s] TERMINALS [t] PRODUCT OPTION [o] LED INDICATOR [u]	[S] [D] [1] [N]	Single DIN Rail Default NO LED	SWITCH TYPE [s] TERMINALS [t] PRODUCT OPTION [o] LED INDICATOR [u] SERIES MODULE [s]	[S] [D] [1] [N] [Sxxxx]	Single DIN Rail Default NO LED Series Device	SWITCH TYPE [s] TERMINALS [t] PRODUCT OPTION [o] LED INDICATOR [u] MODULES [e][s]	[S] [D] [1] [N] [Exxxx][Sxxxx]	Single DIN Rail Default NO LED EOL + Series	SWITCH TYPE [s] TERMINALS [t] PRODUCT OPTION [o] LED INDICATOR [u] MODULE [e][s]	[S] [D] [W] [N] [Exxxx][Sxxxx]	Single DIN Rail Alt. EOL Pos'n. NO LED EOL + Series
---	--------------------------	---	--	-------------------------------------	--	---	--	---	--	--	---

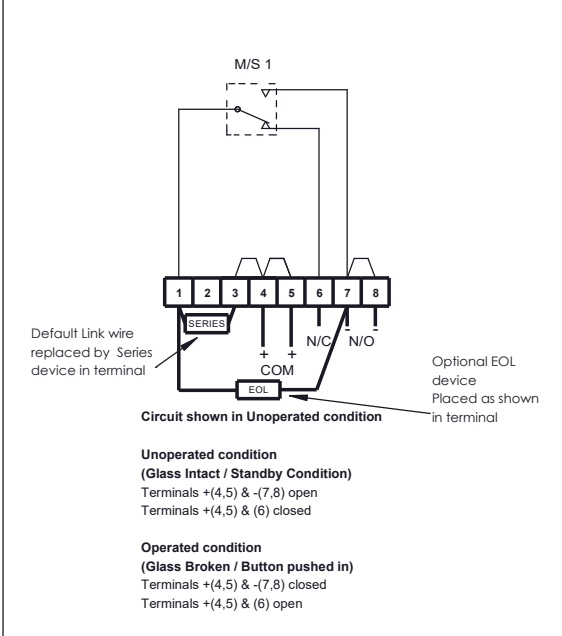
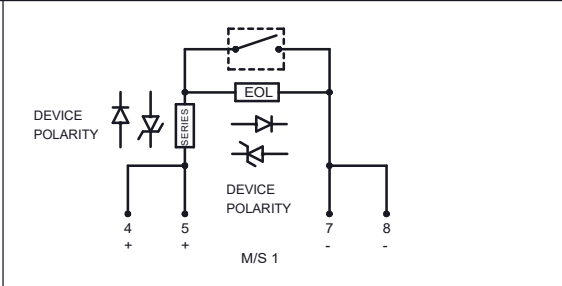
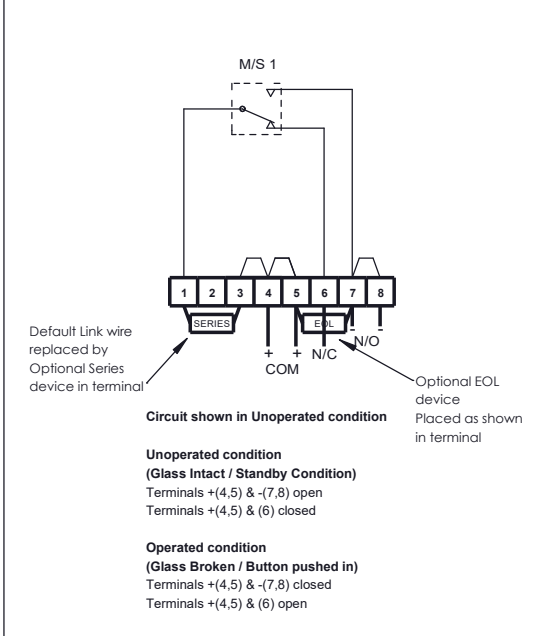
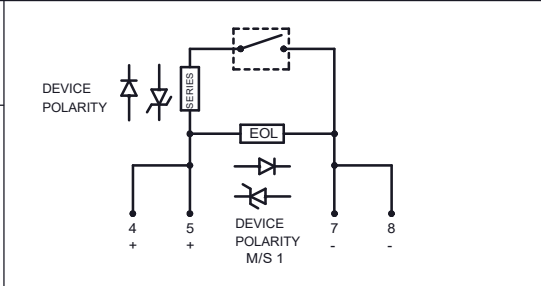
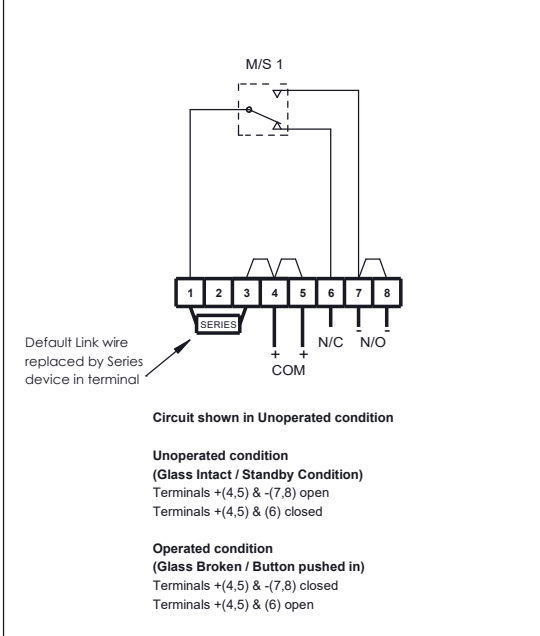
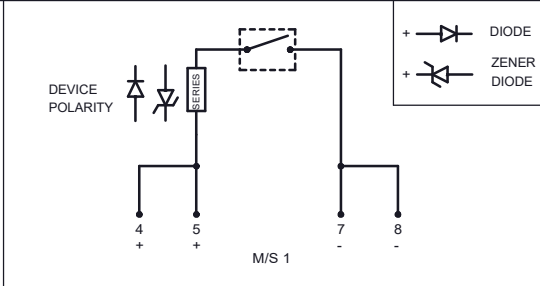
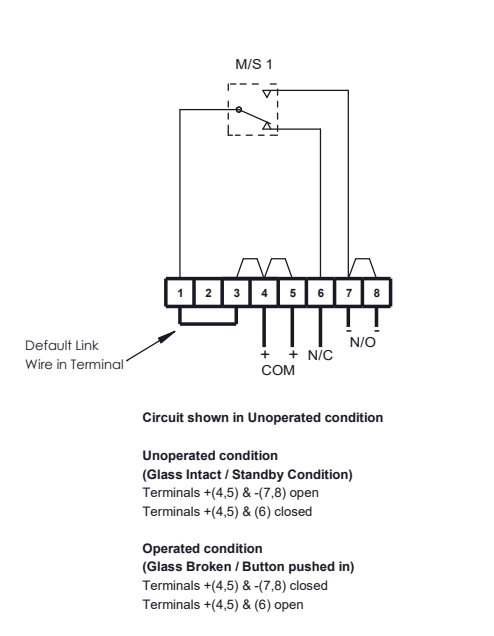
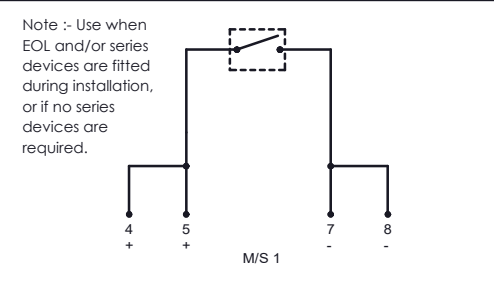

DRAWING TO BS8888:2000 GEOMETRIC TOLERANCES TO ISO1101:1983 LINEAR DIMENSIONAL TOLS ANGULAR DIMENSIONAL TOLS	DRAWN	DATE	SURFACE FINISH	WEIGHT (Kg)
	R.S.RAIT	05-03-2020		
	CHECKED	DATE		
STANDARDS GNEXCP7 ; STEXCP8 ; WP7 units with DIN Rail	B.ISARD	05-03-2020	MATERIAL	ALTERNATIVE MATERIAL
	APPROVED	DATE		
R.N.POTTS	05-03-2020			

THIS DRAWING AND ANY INFORMATION OR DESCRIPTIVE MATTER THEREIN IS COMMUNICATED IN CONFIDENCE AND IS THE COPYRIGHT PROPERTY OF EUROPEAN SAFETY SYSTEMS LTD. NEITHER THE WHOLE OR ANY EXTRACT MAY BE DISCLOSED, LOANED, COPIED OR USED FOR MANUFACTURING OR TENDERING PURPOSES WITHOUT THEIR WRITTEN CONSENT.
EUROPEAN SAFETY SYSTEMS LTD. AS PER LATEST DATE OF ISSUE SHOWN ABOVE

© EUROPEAN SAFETY SYSTEMS LTD.  
AS PER LATEST DATE OF ISSUE SHOWN ABOVE

EUROPEAN SAFETY SYSTEMS LTD  
IMPRESS HOUSE  
MANSELL ROAD  
ACTON  
LONDON W3 7QH  
WWW.E2S.COM

ALL DIMENSIONS IN MM IF IN DOUBT, ASK - DO NOT SCALE				<b>A3</b>
TITLE <b>GNEXCP7 ; STEXCP8 ; WP7 CALL POINT WIRING / CIRCUIT OPERATION DIAGRAM</b>				
SCALE	SHEET	DRAWING NUMBER		
NTS	1 OF 8	<b>D202-06-211</b>		

**DUAL MICROSWITCH DEVICES**

**SHEET 2**

**Module Device Codes**

	EOL	Series
Resistor	ExxxR	SxxxR
Diode	ED1	SD1
Zener Diode	ExxxZ	SxxxZ
LED	N/A	L or C

ISSUE	MOD No.	REASON - INITIAL - DATE
7	ACN0178	Correction to LED wiring in option W RNP 15-04-2025
8	ACN0187	LED put on N/C side of circuit, note on LED LD1 detailed RNP 28-05-2025

Notes:  
1. Other configurations of dual switch units are possible. Contact E2S sales to discuss options.

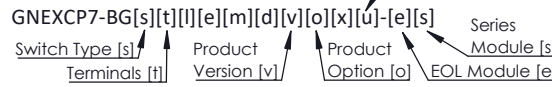

DUAL SWITCH WITH EOL DEVICE	CONFIG. D2-1	DUAL SWITCH WITH SERIES DEVICES	CONFIG. D2-2	DUAL SWITCH WITH EOL & SERIES DEVICES	CONFIG. D2-3	DUAL SWITCH WITH EOL & SERIES DEVICES	CONFIG. D2-4
-----------------------------	--------------	---------------------------------	--------------	---------------------------------------	--------------	---------------------------------------	--------------

SWITCH TYPE [s]	[D]	Dual	[D]	Dual	[D]	Dual	[D]
TERMINALS [t]	[D]	DIN Rail	[D]	DIN Rail Only	[D]	DIN Rail Only	[D]
PRODUCT OPTION [o]	[1]	Default	[1]	Default	[1]	Default	[W]
LED INDICATOR [u]	[N]	NO LED	[N]	NO LED	[N]	NO LED	[N]
SERIES MODULE [s]	[Sxxxx]	Series Device	[Sxxxx]	Series Device	[Exxxx][Sxxxx]	EOL + Series	[Exxxx][Sxxxx]

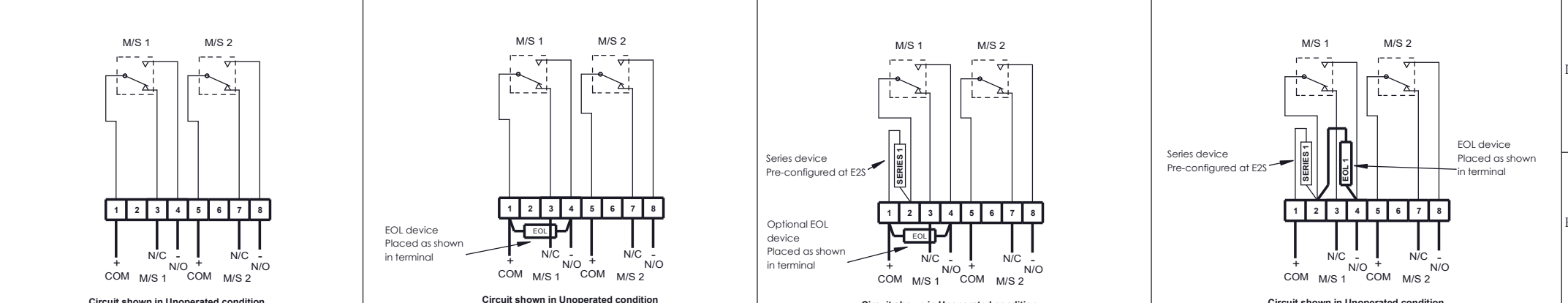
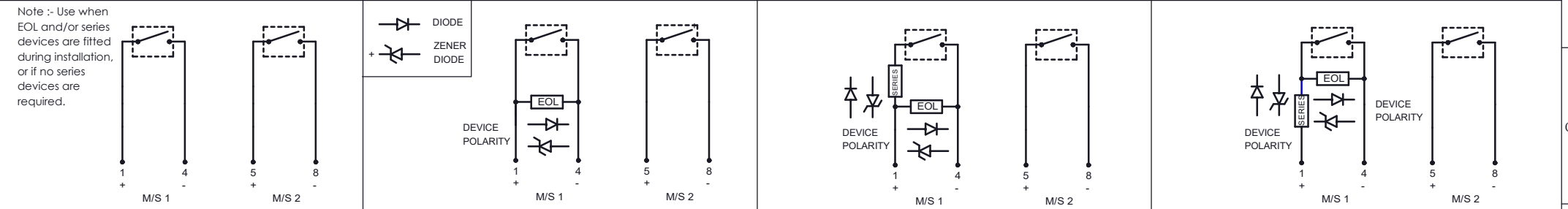

<p><b>Circuit shown in Unoperated condition</b></p> <p><b>Unoperated condition (Glass Intact / Standby Condition)</b> Terminals +(1) &amp; -(4) M/S 1 &amp; +(5) &amp; -(8) M/S 2 open Terminals +(1) &amp; -(3) M/S 1 &amp; +(5) &amp; -(7) M/S 2 closed</p> <p><b>Operated condition (Glass Broken / Button pushed in)</b> Terminals +(1) &amp; -(3) M/S 1 &amp; +(5) &amp; -(7) M/S 2 open Terminals +(1) &amp; -(4) M/S 1 &amp; +(5) &amp; -(8) M/S 2 closed</p>	<p><b>Circuit shown in Unoperated condition</b></p> <p><b>Unoperated condition (Glass Intact / Standby Condition)</b> Terminals +(1) &amp; -(4) M/S 1 &amp; +(5) &amp; -(8) M/S 2 open Terminals +(1) &amp; -(3) M/S 1 &amp; +(5) &amp; -(7) M/S 2 closed</p> <p><b>Operated condition (Glass Broken / Button pushed in)</b> Terminals +(1) &amp; -(3) M/S 1 &amp; +(5) &amp; -(7) M/S 2 open Terminals +(1) &amp; -(4) M/S 1 &amp; +(5) &amp; -(8) M/S 2 closed</p>	<p><b>Circuit shown in Unoperated condition</b></p> <p><b>Unoperated condition (Glass Intact / Standby Condition)</b> Terminals +(1) &amp; -(4) M/S 1 &amp; +(5) &amp; -(8) M/S 2 open Terminals +(1) &amp; -(3) M/S 1 &amp; +(5) &amp; -(7) M/S 2 closed</p> <p><b>Operated condition (Glass Broken / Button pushed in)</b> Terminals +(1) &amp; -(3) M/S 1 &amp; +(5) &amp; -(7) M/S 2 open Terminals +(1) &amp; -(4) M/S 1 &amp; +(5) &amp; -(8) M/S 2 closed</p>	<p><b>Circuit shown in Unoperated condition</b></p> <p><b>Unoperated condition (Glass Intact / Standby Condition)</b> Terminals +(1) &amp; -(4) M/S 1 &amp; +(5) &amp; -(8) M/S 2 open Terminals +(1) &amp; -(3) M/S 1 &amp; +(5) &amp; -(7) M/S 2 closed</p> <p><b>Operated condition (Glass Broken / Button pushed in)</b> Terminals +(1) &amp; -(3) M/S 1 &amp; +(5) &amp; -(7) M/S 2 open Terminals +(1) &amp; -(4) M/S 1 &amp; +(5) &amp; -(8) M/S 2 closed</p>
--	--	--	--

DRAWING TO BS8888:2000  
GEOMETRIC TOLERANCES TO ISO1101:1983  
LINEAR DIMENSIONAL TOLS  
ANGULAR DIMENSIONAL TOLS

STANDARDS  
**GNExCP7 ; STExCP8 ; WP7 units with DIN Rail**

DRAWN	DATE
D.HOWGILL	05-03-2020
CHECKED	DATE
R.N.POTTS	05-03-2020
APPROVED	DATE
R.N.POTTS	05-03-2020

SURFACE FINISH	WEIGHT (Kg)
MATERIAL	
ALTERNATIVE MATERIAL	

THIS DRAWING AND ANY INFORMATION OR DESCRIPTIVE MATTER THEREIN IS COMMUNICATED IN CONFIDENCE AND IS THE COPYRIGHT PROPERTY OF EUROPEAN SAFETY SYSTEMS LTD. NEITHER THE WHOLE OR ANY EXTRACT MAY BE DISCLOSED, LOANED, COPIED OR USED FOR MANUFACTURING OR TENDERING PURPOSES WITHOUT THEIR WRITTEN CONSENT.

EUROPEAN SAFETY SYSTEMS LTD.  
AS PER LATEST DATE OF ISSUE SHOWN ABOVE



ALL DIMENSIONS IN MM  
IF IN DOUBT, ASK - DO NOT SCALE

**A3**

TITLE **GNExCP7 ; STExCP8 ; WP7 CALL POINT WIRING / CIRCUIT OPERATION DIAGRAM**

SCALE	SHEET	DRAWING NUMBER
NTS	2 OF 8	<b>D202-06-211</b>

# DUAL MICROSWITCH DEVICES DUPLICATED

# SHEET 3

## Module Device Codes

	EOL	Series
Resistor	ExxxR	SxxxR
Diode	ED1	SD1
Zener Diode	ExxxZ	SxxxZ
LED	N/A	L or C

ISSUE	MOD No.	REASON - INITIAL - DATE
7	ACN0178	Correction to LED wiring in option W RNP 15-04-2025
8	ACN0187	LED put on N/C side of circuit, note on LED LD1 detailed RNP 28-05-2025

Notes:  
1. Other configurations of dual switch units are possible. Contact E2S sales to discuss options.

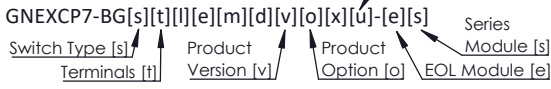

DUAL SWITCH WITH EOL DEVICES DUPLICATED	CONFIG. D3-1	DUAL SWITCH WITH SERIES DEVICES DUPLICATED	CONFIG. D3-2	DUAL SWITCH WITH EOL & SERIES DEVICE DUPLICATED	CONFIG. D3-3	DUAL SWITCH WITH EOL & SERIES DEVICE DUPLICATED	CONFIG. D3-4
---	--------------	--	--------------	---	--------------	---	--------------

SWITCH TYPE [s]	TERMINALS [t]	PRODUCT OPTION [o]	LED INDICATOR [u]	EOL MODULE [e]	CONFIG. D3-1	SWITCH TYPE [s]	TERMINALS [t]	PRODUCT OPTION [o]	LED INDICATOR [u]	SERIES MODULE [s]	CONFIG. D3-2	SWITCH TYPE [s]	TERMINALS [t]	PRODUCT OPTION [o]	LED INDICATOR [u]	MODULES [e][s]	CONFIG. D3-3	SWITCH TYPE [s]	TERMINALS [t]	PRODUCT OPTION [o]	LED INDICATOR [u]	MODULES [e][s]	CONFIG. D3-4
[D]	[D]	[2]	[N]	[Exxxx]	Dual DIN Rail Duplicated NO LED EOL Device	[D]	[D]	[2]	[N]	[Sxxxx]	Dual DIN Rail Only Duplicated NO LED Series Device	[D]	[D]	[2]	[N]	[Exxxx][Sxxxx]	Dual DIN Rail Only Duplicated NO LED EOL + Series	[D]	[D]	[Y]	[N]	[Exxxx][Sxxxx]	Dual DIN Rail Only Alt. EOL Pos'n. DUP. NO LED EOL + Series

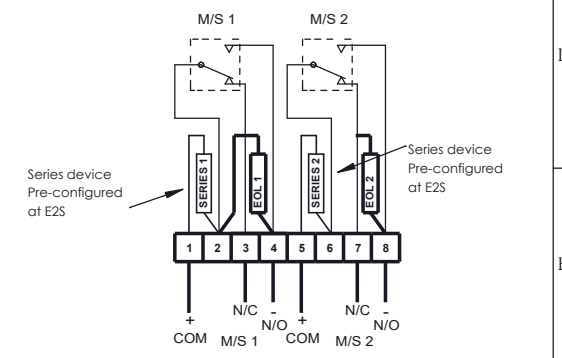
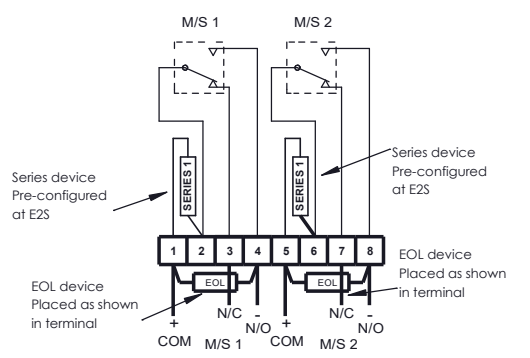
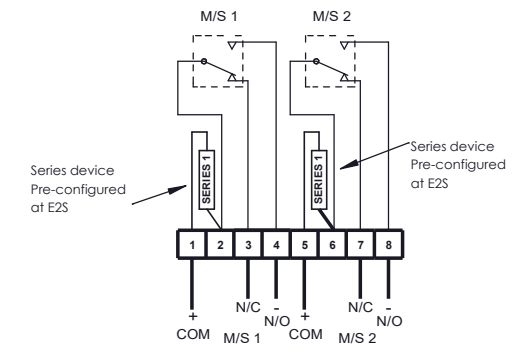
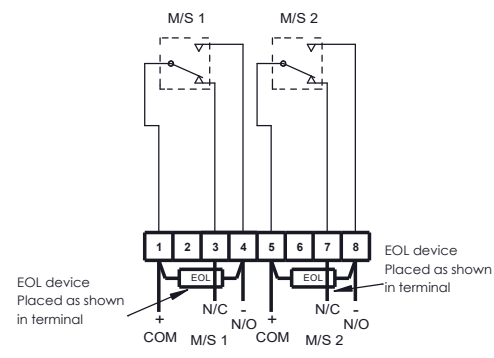
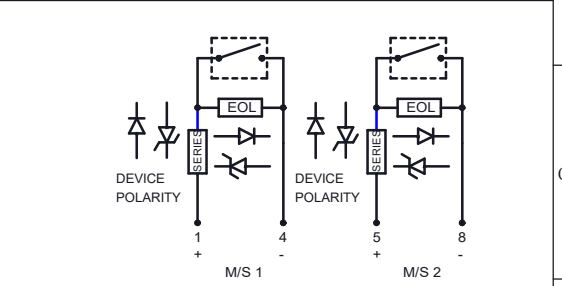
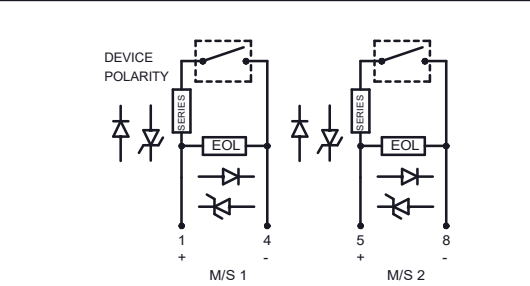
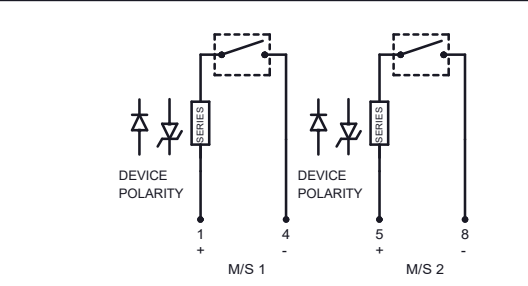
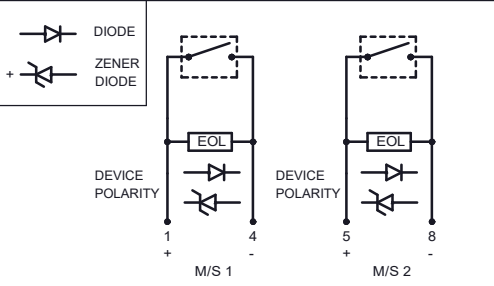

**Circuit shown in Unoperated condition**

**Unoperated condition (Glass Intact / Standby Condition)**  
Terminals +(1) & -(4) M/S 1 & +(5) & -(8) M/S 2 open  
Terminals +(1) & -(3) M/S 1 & +(5) & -(7) M/S 2 closed

**Operated condition (Glass Broken / Button pushed in)**  
Terminals +(1) & -(3) M/S 1 & +(5) & -(7) M/S 2 open  
Terminals +(1) & -(4) M/S 1 & +(5) & -(8) M/S 2 closed

**Circuit shown in Unoperated condition**

**Unoperated condition (Glass Intact / Standby Condition)**  
Terminals +(1) & -(4) M/S 1 & +(5) & -(8) M/S 2 open  
Terminals +(1) & -(3) M/S 1 & +(5) & -(7) M/S 2 closed

**Operated condition (Glass Broken / Button pushed in)**  
Terminals +(1) & -(3) M/S 1 & +(5) & -(7) M/S 2 open  
Terminals +(1) & -(4) M/S 1 & +(5) & -(8) M/S 2 closed

**Circuit shown in Unoperated condition**

**Unoperated condition (Glass Intact / Standby Condition)**  
Terminals +(1) & -(3) M/S 1 & +(5) & -(8) M/S 2 open  
Terminals +(1) & -(3) M/S 1 & +(5) & -(7) M/S 2 closed

**Operated condition (Glass Broken / Button pushed in)**  
Terminals +(1) & -(3) M/S 1 & +(5) & -(7) M/S 2 open  
Terminals +(1) & -(4) M/S 1 & +(5) & -(8) M/S 2 closed

**Circuit shown in Unoperated condition**

**Unoperated condition (Glass Intact / Standby Condition)**  
Terminals +(1) & -(4) M/S 1 & +(5) & -(8) M/S 2 open  
Terminals +(1) & -(3) M/S 1 & +(5) & -(7) M/S 2 closed

**Operated condition (Glass Broken / Button pushed in)**  
Terminals +(1) & -(3) M/S 1 & +(5) & -(7) M/S 2 open  
Terminals +(1) & -(4) M/S 1 & +(5) & -(8) M/S 2 closed

DRAWING TO BS8888:2000  
GEOMETRIC TOLERANCES TO ISO1101:1983  
LINEAR DIMENSIONAL TOLS  
ANGULAR DIMENSIONAL TOLS

STANDARDS  
**GNExCP7 ; STExCP8 ; WP7 units with DIN Rail**

DRAWN DATE  
**D.HOWGILL 05-03-2020**

CHECKED DATE  
**R.N.POTTS 05-03-2020**

APPROVED DATE  
**R.N.POTTS 05-03-2020**

SURFACE FINISH WEIGHT (Kg)

MATERIAL

ALTERNATIVE MATERIAL

THIS DRAWING AND ANY INFORMATION OR DESCRIPTIVE MATTER THEREIN IS COMMUNICATED IN CONFIDENCE AND IS THE COPYRIGHT PROPERTY OF EUROPEAN SAFETY SYSTEMS LTD. NEITHER THE WHOLE OR ANY EXTRACT MAY BE DISCLOSED, LOANED, COPIED OR USED FOR MANUFACTURING OR TENDERING PURPOSES WITHOUT THEIR WRITTEN CONSENT.

EUROPEAN SAFETY SYSTEMS LTD.  
AS PER LATEST DATE OF ISSUE SHOWN ABOVE

**e2s**  
warning signals

EUROPEAN SAFETY SYSTEMS LTD  
IMPRESS HOUSE  
MANSELL ROAD  
ACTON  
LONDON W3 7QH  
WWW.E2S.COM

ALL DIMENSIONS IN MM  
IF IN DOUBT, ASK - DO NOT SCALE

**A3**

TITLE **GNExCP7 ; STExCP8 ; WP7 CALL POINT WIRING / CIRCUIT OPERATION DIAGRAM**

SCALE SHEET DRAWING NUMBER  
NTS 3 OF 8 **D202-06-211**

**SINGLE MICROSWITCH LED DEVICES**

**SHEET 4**



Module Device Codes		
	EOL	Series
Resistor	ExxxR	SxxxR
Diode	ED1	SD1
Zener Diode	ExxxZ	SxxxZ
LED	N/A	L or C

ISSUE	MOD No.	REASON - INITIAL - DATE
7	ACN0178	Correction to LED wiring in option W RNP 15-04-2025
8	ACN0187	LED put on N/C side of circuit, note on LED LD1 detailed RNP 28-05-2025

SINGLE SWITCH WITH LED ONLY	CONFIG. D4-1	SINGLE SWITCH WITH LED & EOL DEVICE	CONFIG. D4-2	SINGLE SWITCH WITH LED EOL & SERIES DEVICES	CONFIG. D4-3	SINGLE SWITCH WITH LED, EOL & ALT. SERIES DEVICE	CONFIG. D4-4
-----------------------------	--------------	-------------------------------------	--------------	---	--------------	--	--------------

SWITCH TYPE [s]	[S]	Single	SWITCH TYPE [s]	[S]	Single	SWITCH TYPE [s]	[S]	Single
TERMINALS [t]	[D]	DIN Rail	TERMINALS [t]	[D]	DIN Rail	TERMINALS [t]	[D]	DIN Rail
PRODUCT OPTION [o]	[1]	Default	PRODUCT OPTION [o]	[1]	Default	PRODUCT OPTION [o]	[W]	Alt. EOL Pos'n.
LED INDICATOR [u]	[L]	LED with RL1	LED INDICATOR [u]	[L]	LED with RL1	LED INDICATOR [u]	[L]	LED with RL1
			SERIES MODULE [e]	[Exxxx]	EOL Device	EOL MODULE [e][s]	[Exxxx][Sxxxx]	EOL + Series Device

Notes - For all LED Options:

1) The LED is configured as LED indicator option 'C' for this version the LED must be protected by a series resistor of a minimum value of 1.5K Ohm or by limiting the systems current to 20mA max

2) Units have the option to add the LED current-limiting resistor RL1 LED indicator option 'L' which is 1.5K Ohms.

3) Note that in both cases the total value of the series resistors and if fitted RL1 will impact the brightness of the LED.

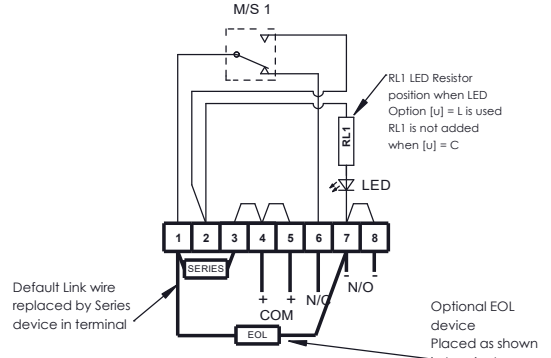
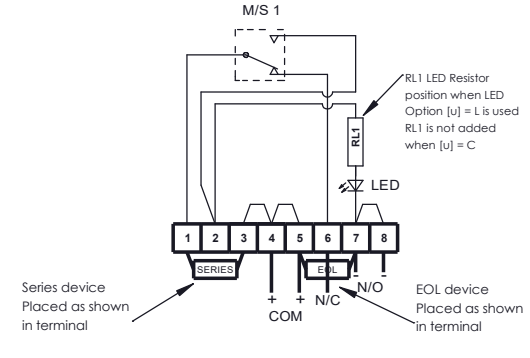
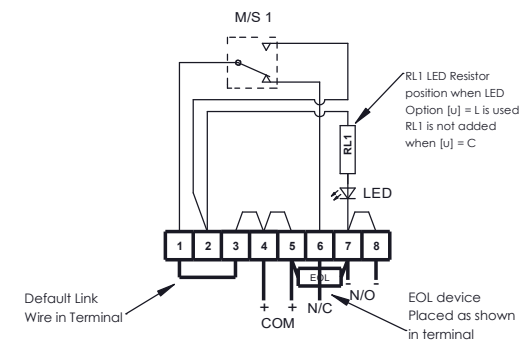
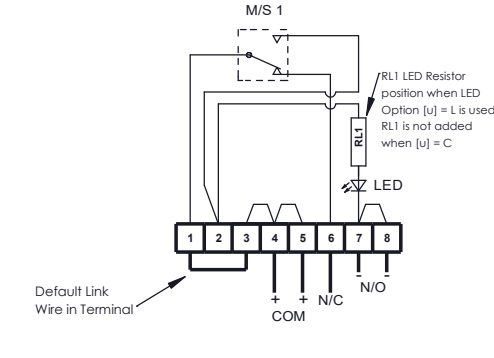
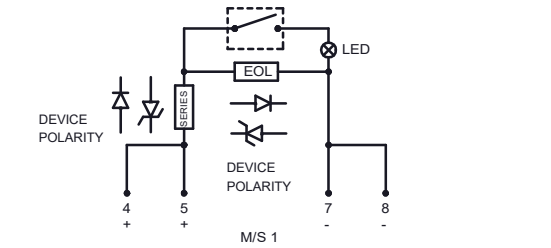
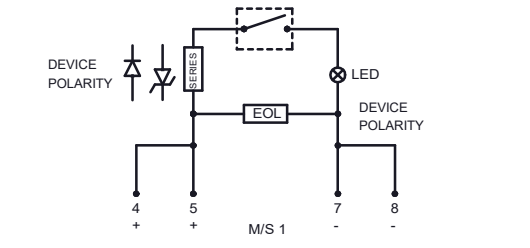
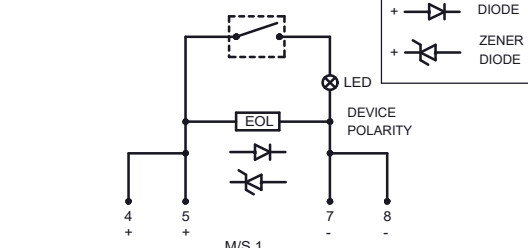
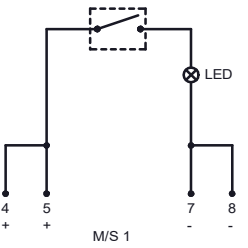

**Circuit shown in Unoperated condition**

**Unoperated condition (Glass Intact / Standby Condition)**  
Terminals +(4,5) & -(7,8) open  
Terminals +(4,5) & (6) closed

**Operated condition (Glass Broken / Button pushed in)**  
Terminals +(4,5) & -(7,8) closed  
Terminals +(4,5) & (6) open

**Circuit shown in Unoperated condition**

**Unoperated condition (Glass Intact / Standby Condition)**  
Terminals +(4,5) & -(7,8) open  
Terminals +(4,5) & (6) closed

**Operated condition (Glass Broken / Button pushed in)**  
Terminals +(4,5) & -(7,8) closed  
Terminals +(4,5) & (6) open

**Circuit shown in Unoperated condition**

**Unoperated condition (Glass Intact / Standby Condition)**  
Terminals +(4,5) & -(7,8) open  
Terminals +(4,5) & (6) closed

**Operated condition (Glass Broken / Button pushed in)**  
Terminals +(4,5) & -(7,8) closed  
Terminals +(4,5) & (6) open

**Circuit shown in Unoperated condition**

**Unoperated condition (Glass Intact / Standby Condition)**  
Terminals +(4,5) & -(7,8) open  
Terminals +(4,5) & (6) closed

**Operated condition (Glass Broken / Button pushed in)**  
Terminals +(4,5) & -(7,8) closed  
Terminals +(4,5) & (6) open

DRAWING TO BS8888:2000  
GEOMETRIC TOLERANCES TO ISO1101:1983  
LINEAR DIMENSIONAL TOLS  
ANGULAR DIMENSIONAL TOLS

STANDARDS  
**GNExCP7 ; STExCP8 ; WP7 units with DIN Rail**

DRAWN	DATE
D.HOWGILL	05-03-2020
CHECKED	DATE
R.N.POTTS	05-03-2020
APPROVED	DATE
R.N.POTTS	05-03-2020

SURFACE FINISH	WEIGHT (Kg)
MATERIAL	
ALTERNATIVE MATERIAL	

THIS DRAWING AND ANY INFORMATION OR DESCRIPTIVE MATTER THEREIN IS COMMUNICATED IN CONFIDENCE AND IS THE COPYRIGHT PROPERTY OF EUROPEAN SAFETY SYSTEMS LTD. NEITHER THE WHOLE OR ANY EXTRACT MAY BE DISCLOSED, LOANED, COPIED OR USED FOR MANUFACTURING OR TENDERING PURPOSES WITHOUT THEIR WRITTEN CONSENT.

EUROPEAN SAFETY SYSTEMS LTD.  
AS PER LATEST DATE OF ISSUE SHOWN ABOVE

EUROPEAN SAFETY SYSTEMS LTD  
IMPRESS HOUSE  
MANSELL ROAD  
ACTON  
LONDON W3 7QH  
WWW.E2S.COM

ALL DIMENSIONS IN MM IF IN DOUBT, ASK - DO NOT SCALE				<b>A3</b>
TITLE <b>GNExCP7 ; STExCP8 ; WP7 CALL POINT WIRING / CIRCUIT OPERATION DIAGRAM</b>				
SCALE	SHEET	DRAWING NUMBER		
NTS	4 OF 8	<b>D202-06-211</b>		

**DUAL MICROSWITCH LED DEVICES**

**SHEET 5**

GNEXCP7-BG[s][t][l][e][m][d][v][o][x][u]-[e][s]  
 Switch Type [s] Terminals [t] Product Version [v] Product Option [o] EOL Module [e] Series Module [s]  
 LED Indicator [u]

Module Device Codes		
	EOL	Series
Resistor	ExxxR	SxxxR
Diode	ED1	SD1
Zener Diode	ExxxZ	SxxxZ
LED	N/A	L or C

ISSUE	MOD No.	REASON - INITIAL - DATE
7	ACN0178	Correction to LED wiring in option W RNP 15-04-2025
8	ACN0187	LED put on N/C side of circuit, note on LED LD1 detailed RNP 28-05-2025

DUAL SWITCH WITH LED	CONFIG. D5-1	DUAL SWITCH WITH LED & EOL DEVICES	CONFIG. D5-2	DUAL SWITCH WITH LED EOL & SERIES DEVICES	CONFIG. D5-3	DUAL SWITCH WITH LED, EOL & ALT. SERIES DEVICE	CONFIG. D5-4
----------------------	--------------	------------------------------------	--------------	---	--------------	--	--------------

SWITCH TYPE [s]	[D] Dual	SWITCH TYPE [s]	[D] Dual	SWITCH TYPE [s]	[D] Dual	SWITCH TYPE [s]	[D] Dual
TERMINALS [t]	[D] DIN Rail Only	TERMINALS [t]	[D] DIN Rail Only	TERMINALS [t]	[D] DIN Rail Only	TERMINALS [t]	[D] DIN Rail Only
PRODUCT OPTION [o]	[1] Default	PRODUCT OPTION [o]	[1] Default	PRODUCT OPTION [o]	[1] Default	PRODUCT OPTION [o]	[W] Alt. EOL Pos'n.
LED INDICATOR [u]	[L] LED with RL1	LED INDICATOR [u]	[L] LED with RL1	LED INDICATOR [u]	[L] LED with RL1	LED INDICATOR [u]	[L] LED with RL1
		EOL MODULE [e]	[ExxxR] EOL Device	SERIES MODULE [s]	[Sxxxx] Series Device	MODULES [e][s]	[Exxxx][Sxxxx] EOL + Series

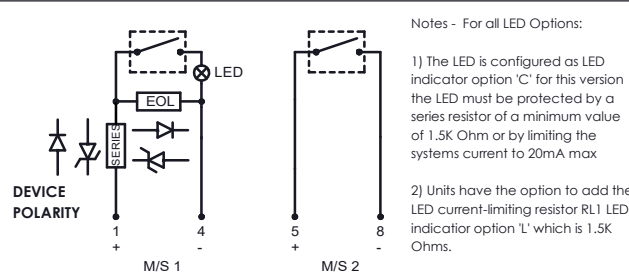
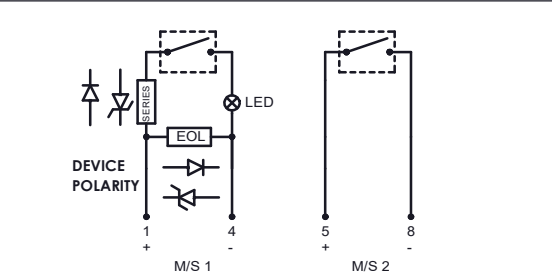
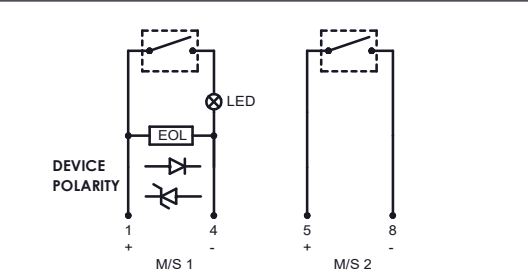
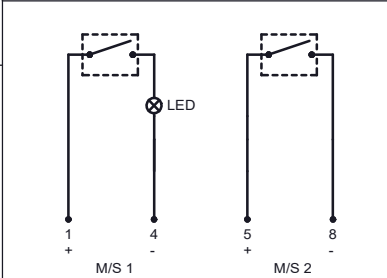

Notes - For all LED Options:  
 1) The LED is configured as LED indicator option 'C' for this version the LED must be protected by a series resistor of a minimum value of 1.5K Ohm or by limiting the systems current to 20mA max  
 2) Units have the option to add the LED current-limiting resistor RL1 LED indicator option 'L' which is 1.5K Ohms.  
 3) Note that in both cases the total value of the series resistors and if fitted RL1 will impact the brightness of the LED.

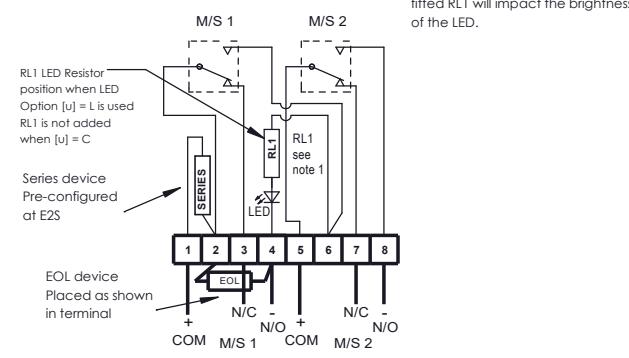
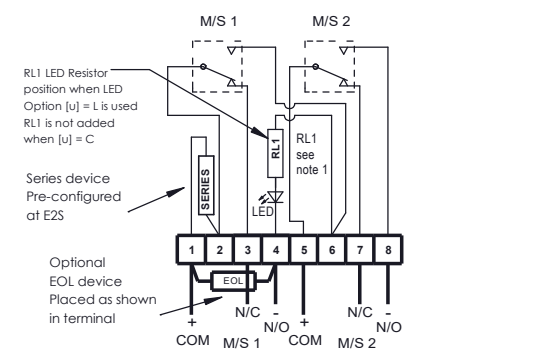
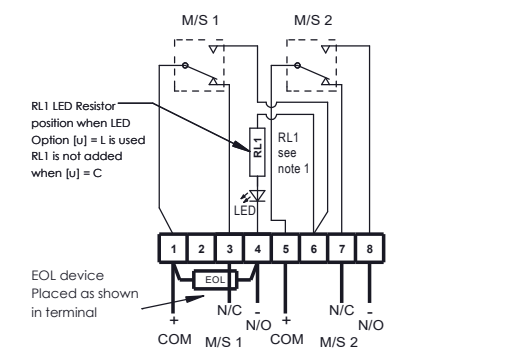
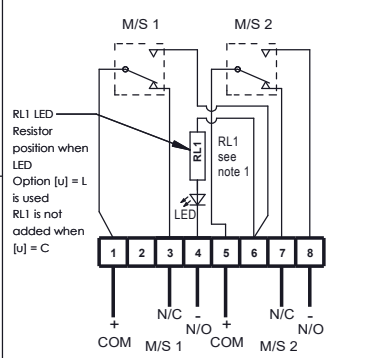

**Circuit shown in Unoperated condition**

**Unoperated condition (Glass Intact / Standby Condition)**  
 Terminals +(1) & -(4) M/S 1 & +(5) & -(8) M/S 2 open  
 Terminals +(1) & -(3) M/S 1 & +(5) & -(7) M/S 2 closed

**Operated condition (Glass Broken / Button pushed in)**  
 Terminals +(1) & -(3) M/S 1 & +(5) & -(7) M/S 2 open  
 Terminals +(1) & -(4) M/S 1 & +(5) & -(8) M/S 2 closed

**Circuit shown in Unoperated condition**

**Unoperated condition (Glass Intact / Standby Condition)**  
 Terminals +(1) & -(4) M/S 1 & +(5) & -(8) M/S 2 open  
 Terminals +(1) & -(3) M/S 1 & +(5) & -(7) M/S 2 closed

**Operated condition (Glass Broken / Button pushed in)**  
 Terminals +(1) & -(3) M/S 1 & +(5) & -(7) M/S 2 open  
 Terminals +(1) & -(4) M/S 1 & +(5) & -(8) M/S 2 closed

**Circuit shown in Unoperated condition**

**Unoperated condition (Glass Intact / Standby Condition)**  
 Terminals +(1) & -(4) M/S 1 & +(5) & -(8) M/S 2 open  
 Terminals +(1) & -(3) M/S 1 & +(5) & -(7) M/S 2 closed

**Operated condition (Glass Broken / Button pushed in)**  
 Terminals +(1) & -(3) M/S 1 & +(5) & -(7) M/S 2 open  
 Terminals +(1) & -(4) M/S 1 & +(5) & -(8) M/S 2 closed

**Circuit shown in Unoperated condition**

**Unoperated condition (Glass Intact / Standby Condition)**  
 Terminals +(1) & -(4) M/S 1 & +(5) & -(8) M/S 2 open  
 Terminals +(1) & -(3) M/S 1 & +(5) & -(7) M/S 2 closed

**Operated condition (Glass Broken / Button pushed in)**  
 Terminals +(1) & -(3) M/S 1 & +(5) & -(7) M/S 2 open  
 Terminals +(1) & -(4) M/S 1 & +(5) & -(8) M/S 2 closed

DRAWING TO BS8888:2000  
 GEOMETRIC TOLERANCES TO ISO1101:1983  
 LINEAR DIMENSIONAL TOLS  
 ANGULAR DIMENSIONAL TOLS

STANDARDS

DRAWN	DATE
D.HOWGILL	05-03-2020
CHECKED	DATE
R.N.POTTS	05-03-2020
APPROVED	DATE
R.N.POTTS	05-03-2020

SURFACE FINISH	WEIGHT (Kg)
MATERIAL	
ALTERNATIVE MATERIAL	

THIS DRAWING AND ANY INFORMATION OR DESCRIPTIVE MATTER THEREIN IS COMMUNICATED IN CONFIDENCE AND IS THE COPYRIGHT PROPERTY OF EUROPEAN SAFETY SYSTEMS LTD. NEITHER THE WHOLE OR ANY EXTRACT MAY BE DISCLOSED, LOANED, COPIED OR USED FOR MANUFACTURING OR TENDERING PURPOSES WITHOUT THEIR WRITTEN CONSENT.

EUROPEAN SAFETY SYSTEMS LTD.  
 AS PER LATEST DATE OF ISSUE SHOWN ABOVE

EUROPEAN SAFETY SYSTEMS LTD  
 IMPRESS HOUSE  
 MANSELL ROAD  
 ACTON  
 LONDON W3 7QH  
 WWW.E2S.COM

ALL DIMENSIONS IN MM IF IN DOUBT, ASK - DO NOT SCALE				<b>A3</b>
TITLE <b>GNExCP7 ; STExCP8 ; WP7 CALL POINT WIRING / CIRCUIT OPERATION DIAGRAM</b>				
SCALE	SHEET	DRAWING NUMBER		
NTS	5 OF 8	<b>D202-06-211</b>		

DUAL MICROSWITCH LED & DEVICES DUPLICATED

SHEET 6



Module Device Codes		
	EOL	Series
Resistor	ExxxR	SxxxR
Diode	ED1	SD1
Zener Diode	ExxxZ	SxxxZ
LED	N/A	L or C

ISSUE	MOD No.	REASON - INITIAL - DATE
7	ACN0178	Correction to LED wiring in option W RNP 15-04-2025
8	ACN0187	LED put on N/C side of circuit, note on LED LD1 detailed RNP 28-05-2025

DUAL SWITCH WITH LED & EOL DEVICE

CONFIG. D6-1

DUAL SWITCH WITH LED & SERIES DEVICE

CONFIG. D6-2

DUAL SWITCH WITH LED, EOL & SERIES DEVICE

CONFIG. D6-3

SWITCH TYPE [s] [D] Dual  
 TERMINALS [t] [D] DIN Rail Only  
 PRODUCT OPTION [o] [2] Duplicated EOL  
 LED INDICATOR [u] [L] LED with RL1  
 EOL MODULE [e] [ExxxR] EOL Device

SWITCH TYPE [s] [D] Dual  
 TERMINALS [t] [D] DIN Rail Only  
 PRODUCT OPTION [o] [2] Duplicated EOL / SERIES  
 LED INDICATOR [u] [L] LED with RL1  
 SERIES MODULE [s] [Sxxxx] Series Device

SWITCH TYPE [s] [D] Dual  
 TERMINALS [t] [D] DIN Rail Only  
 PRODUCT OPTION [o] [Y] Alt. EOL Pos'n. DUPLICATED  
 LED INDICATOR [u] [L] LED with RL1  
 MODULES [e][s] [Exxxx][Sxxxx] EOL + Series

Notes - For all LED Options:

1) The LED is configured as LED indicator option 'C' for this version the LED must be protected by a series resistor of a minimum value of 1.5K Ohm or by limiting the systems current to 20mA max

2) Units have the option to add the LED current-limiting resistor RL1 LED indicator option 'L' which is 1.5K Ohms.

3) Note that in both cases the total value of the series resistors and if fitted RL1 will impact the brightness of the LED.

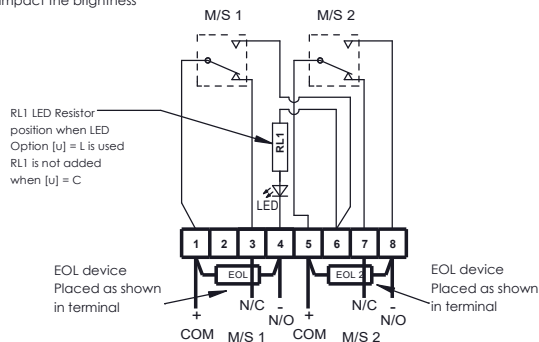
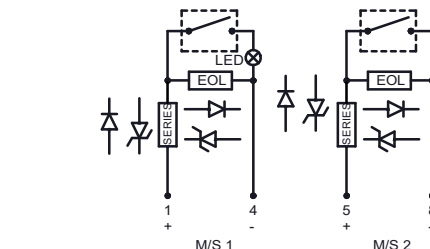
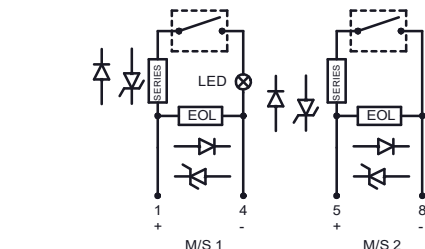
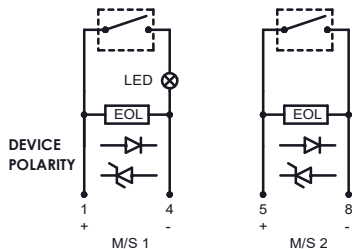

**Circuit shown in Unoperated condition**

**Unoperated condition (Glass Intact / Standby Condition)**  
 Terminals +(1) & -(4) M/S 1 & +(5) & -(8) M/S 2 open  
 Terminals +(1) & -(3) M/S 1 & +(5) & -(7) M/S 2 closed

**Operated condition (Glass Broken / Button pushed in)**  
 Terminals +(1) & -(3) M/S 1 & +(5) & -(7) M/S 2 open  
 Terminals +(1) & -(4) M/S 1 & +(5) & -(8) M/S 2 closed

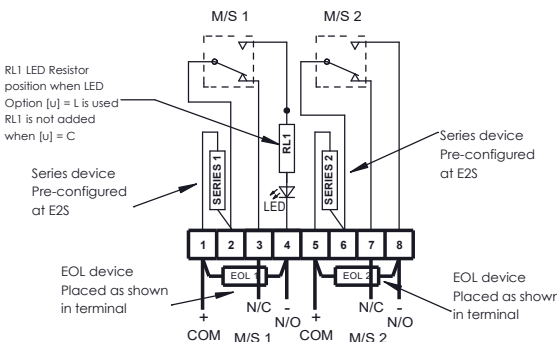

**Circuit shown in Unoperated condition**

**Unoperated condition (Glass Intact / Standby Condition)**  
 Terminals +(1) & -(4) M/S 1 & +(5) & -(8) M/S 2 open  
 Terminals +(1) & -(3) M/S 1 & +(5) & -(7) M/S 2 closed

**Operated condition (Glass Broken / Button pushed in)**  
 Terminals +(1) & -(3) M/S 1 & +(5) & -(7) M/S 2 open  
 Terminals +(1) & -(4) M/S 1 & +(5) & -(8) M/S 2 closed

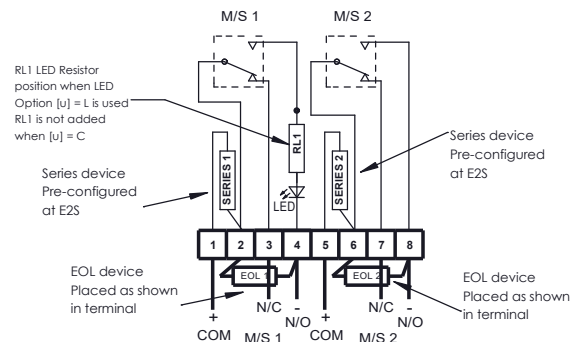

**Circuit shown in Unoperated condition**

**Unoperated condition (Glass Intact / Standby Condition)**  
 Terminals +(1) & -(4) M/S 1 & +(5) & -(8) M/S 2 open  
 Terminals +(1) & -(3) M/S 1 & +(5) & -(7) M/S 2 closed

**Operated condition (Glass Broken / Button pushed in)**  
 Terminals +(1) & -(3) M/S 1 & +(5) & -(7) M/S 2 open  
 Terminals +(1) & -(4) M/S 1 & +(5) & -(8) M/S 2 closed

DRAWING TO BS8888:2000  
 GEOMETRIC TOLERANCES TO ISO1101:1983  
 LINEAR DIMENSIONAL TOLS  
 ANGULAR DIMENSIONAL TOLS

DRAWN D.HOWGILL DATE 05-03-2020

CHECKED R.N.POTTS DATE 05-03-2020

APPROVED R.N.POTTS DATE 05-03-2020

SURFACE FINISH WEIGHT (Kg)

MATERIAL

ALTERNATIVE MATERIAL

THIS DRAWING AND ANY INFORMATION OR DESCRIPTIVE MATTER THEREIN IS COMMUNICATED IN CONFIDENCE AND IS THE COPYRIGHT PROPERTY OF EUROPEAN SAFETY SYSTEMS LTD. NEITHER THE WHOLE OR ANY EXTRACT MAY BE DISCLOSED, LOANED, COPIED OR USED FOR MANUFACTURING OR TENDERING PURPOSES WITHOUT THEIR WRITTEN CONSENT.

EUROPEAN SAFETY SYSTEMS LTD. AS PER LATEST DATE OF ISSUE SHOWN ABOVE



EUROPEAN SAFETY SYSTEMS LTD  
 IMPRESS HOUSE  
 MANSELL ROAD  
 ACTON  
 LONDON W3 7QH  
 WWW.E2S.COM

ALL DIMENSIONS IN MM  
 IF IN DOUBT, ASK -  
 DO NOT SCALE



A3

TITLE GNEXCP7 ; STEXCP8 ; WP7 CALL POINT WIRING / CIRCUIT OPERATION DIAGRAM

SCALE NTS SHEET 6 OF 8

DRAWING NUMBER D202-06-211

# DUAL MICROSWITCHES IN PARALLEL

# SHEET 7

Notes:  
1. Other configurations of dual switch units are possible. Contact E2S sales to discuss options.

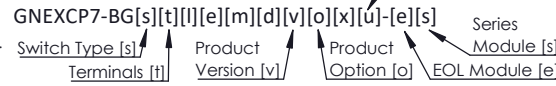

Module Device Codes		
	EOL	Series
Resistor	ExxxR	SxxxR
Diode	ED1	SD1
Zener Diode	ExxxZ	SxxxZ
LED	N/A	L or C

ISSUE	MOD No.	REASON - INITIAL - DATE
7	ACN0178	Correction to LED wiring in option W RNP 15-04-2025
8	ACN0187	LED put on N/C side of circuit, note on LED LD1 detailed RNP 28-05-2025

DUAL SWITCH WITH EOL DEVICE	CONFIG. D7-1	DUAL SWITCH WITH SERIES DEVICES	CONFIG. D7-2	DUAL SWITCH WITH EOL & SERIES DEVICE	CONFIG. D7-3	DUAL SWITCH WITH EOL & SERIES DEVICE	CONFIG. D7-4
-----------------------------	--------------	---------------------------------	--------------	--------------------------------------	--------------	--------------------------------------	--------------

SWITCH TYPE [s]	[D]	Dual	SWITCH TYPE [s]	[D]	Dual	SWITCH TYPE [s]	[D]	Dual	SWITCH TYPE [s]	[D]	Dual
TERMINALS [t]	[D]	DIN Rail	TERMINALS [t]	[D]	DIN Rail	TERMINALS [t]	[D]	DIN Rail	TERMINALS [t]	[D]	DIN Rail Only
PRODUCT OPTION [o]	[P]	Parallel Wiring	PRODUCT OPTION [o]	[P]	Parallel Wiring	PRODUCT OPTION [o]	[V]	Parallel Wiring	PRODUCT OPTION [o]	[V]	Alt. EOL Pos'n
LED INDICATOR [u]	[N]	No LED	LED INDICATOR [u]	[N]	No LED	LED INDICATOR [u]	[N]	No LED	LED INDICATOR [u]	[N]	No LED
			SERIES MODULE [s]	[Sxxxx]	Series Device	MODULE [e][s]	[Exxxx][Sxxxx]	EOL & Series Device	MODULE [e][s]	[Exxxx][Sxxxx]	EOL & Series Devices

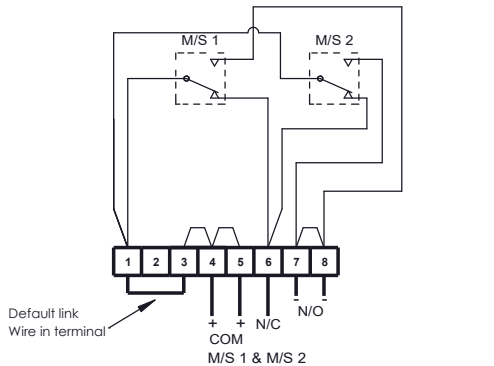
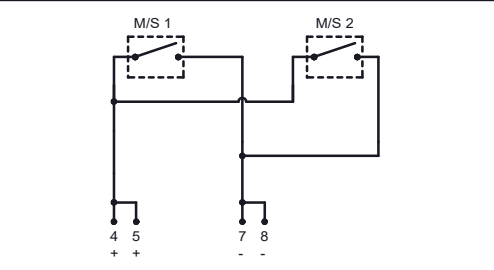

**Circuit shown in Unoperated condition**

**Unoperated condition (Glass Intact / Standby Condition)**  
Terminals +(4,5) & -(7,8) open  
Terminals +(4,5) & (6) closed

**Operated condition (Glass Broken / Button pushed in)**  
Terminals +(4,5) & -(7,8) closed  
Terminals +(4,5) & (6) open

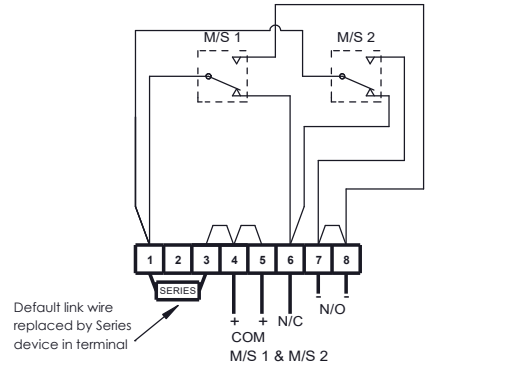
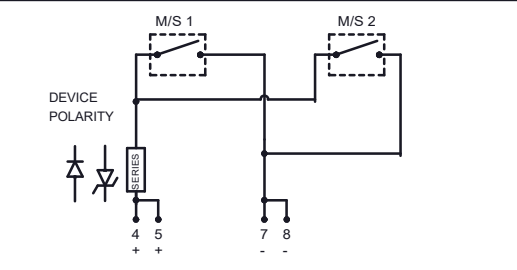

**Circuit shown in Unoperated condition**

**Unoperated condition (Glass Intact / Standby Condition)**  
Terminals +(4,5) & -(7,8) open  
Terminals +(4,5) & (6) closed

**Operated condition (Glass Broken / Button pushed in)**  
Terminals +(4,5) & -(7,8) closed  
Terminals +(4,5) & (6) open

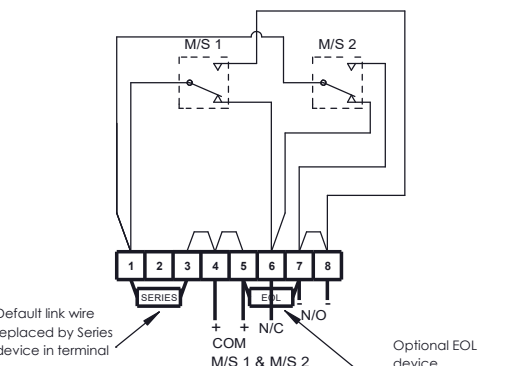
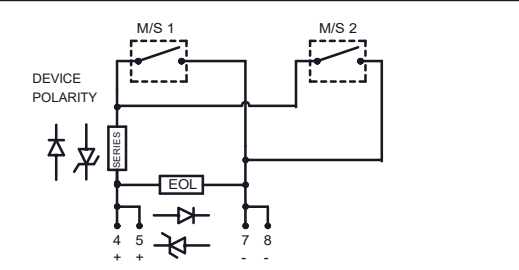

**Circuit shown in Unoperated condition**

**Unoperated condition (Glass Intact / Standby Condition)**  
Terminals +(4,5) & -(7,8) open  
Terminals +(4,5) & (6) closed

**Operated condition (Glass Broken / Button pushed in)**  
Terminals +(4,5) & -(7,8) closed  
Terminals +(4,5) & (6) open

Optional EOL device  
Placed as shown in terminal

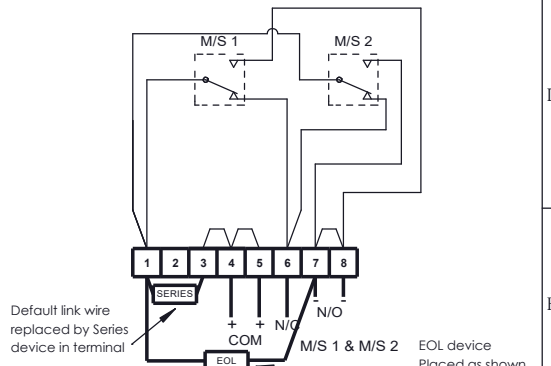
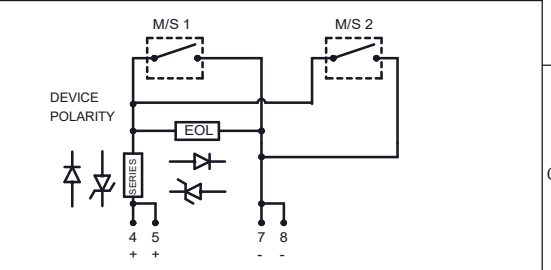

**Circuit shown in Unoperated condition**

**Unoperated condition (Glass Intact / Standby Condition)**  
Terminals +(4,5) & -(7,8) open  
Terminals +(4,5) & (6) closed

**Operated condition (Glass Broken / Button pushed in)**  
Terminals +(4,5) & -(7,8) closed  
Terminals +(4,5) & (6) open

EOL device  
Placed as shown in terminal

DRAWING TO BS8888:2000 GEOMETRIC TOLERANCES TO ISO1101:1983 LINEAR DIMENSIONAL TOLS ANGULAR DIMENSIONAL TOLS	DRAWN	DATE	SURFACE FINISH	WEIGHT (Kg)
	D.HOWGILL	05-03-2020		
	CHECKED	DATE		
STANDARDS GNExCP7 ; STExCP8 ; WP7 units with DIN Rail	R.N.POTTS	05-03-2020	ALTERNATIVE MATERIAL	
	APPROVED	DATE		
	R.N.POTTS	05-03-2020		

THIS DRAWING AND ANY INFORMATION OR DESCRIPTIVE MATTER THEREIN IS COMMUNICATED IN CONFIDENCE AND IS THE COPYRIGHT PROPERTY OF EUROPEAN SAFETY SYSTEMS LTD. NEITHER THE WHOLE OR ANY EXTRACT MAY BE DISCLOSED, LOANED, COPIED OR USED FOR MANUFACTURING OR TENDERING PURPOSES WITHOUT THEIR WRITTEN CONSENT.

EUROPEAN SAFETY SYSTEMS LTD.  
AS PER LATEST DATE OF ISSUE SHOWN ABOVE

EUROPEAN SAFETY SYSTEMS LTD  
IMPRESS HOUSE  
MANSELL ROAD  
ACTON  
LONDON W3 7QH  
WWW.E2S.COM

ALL DIMENSIONS IN MM IF IN DOUBT, ASK - DO NOT SCALE				<b>A3</b>
TITLE <b>GNExCP7 ; STExCP8 ; WP7 CALL POINT WIRING / CIRCUIT OPERATION DIAGRAM</b>				
SCALE	SHEET	DRAWING NUMBER		
NTS	7 OF 8	<b>D202-06-211</b>		

**DUAL MICROSWITCHES IN PARALLEL, LED & DEVICES**

**SHEET 8**



Module Device Codes		
	EOL	Series
Resistor	ExxxR	SxxxR
Diode	ED1	SD1
Zener Diode	ExxxZ	SxxxZ
LED	N/A	L or C

ISSUE	MOD No.	REASON - INITIAL - DATE
7	ACN0178	Correction to LED wiring in option W RNP 15-04-2025
8	ACN0187	LED put on N/C side of circuit, note on LED LD1 detailed RNP 28-05-2025

<b>DUAL SWITCH WITH LED</b>	<b>CONFIG. D8-1</b>	<b>DUAL SWITCH WITH LED &amp; EOL DEVICE</b>	<b>CONFIG. D8-2</b>	<b>DUAL SWITCH WITH EOL &amp; SERIES DEVICE</b>	<b>CONFIG. D8-3</b>	<b>DUAL SWITCH WITH EOL &amp; SERIES DEVICE</b>	<b>CONFIG. D8-4</b>
-----------------------------	---------------------	--	---------------------	---	---------------------	---	---------------------

SWITCH TYPE [s]	[D]	Dual	SWITCH TYPE [s]	[D]	Dual	SWITCH TYPE [s]	[D]	Dual	SWITCH TYPE [s]	[D]	Dual
TERMINALS [t]	[D]	DIN Rail	TERMINALS [t]	[D]	DIN Rail	TERMINALS [t]	[D]	DIN Rail Only	TERMINALS [t]	[D]	DIN Rail Only
PRODUCT OPTION [o]	[P]	Parallel Wiring	PRODUCT OPTION [o]	[P]	Parallel Wiring	PRODUCT OPTION [o]	[P]	Parallel Wiring	PRODUCT OPTION [o]	[V]	Parallel Wiring Alt. EOL
LED INDICATOR [u]	[L]	LED with RL1	LED INDICATOR [u]	[L]	LED with RL1	LED INDICATOR [u]	[L]	LED with RL1	LED INDICATOR [u]	[L]	LED with RL1
			EOL MODULE [e]	[Exxxx]	EOL Device	MODULE [e][s]	[Exxxx][Sxxxx]	EOL + Series	MODULE [e][s]	[Exxxx][Sxxxx]	EOL + Series

Notes - For all LED Options:

1) The LED is configured as LED indicator option 'C' for this version the LED must be protected by a series resistor of a minimum value of 1.5K Ohm or by limiting the systems current to 20mA max

2) Units have the option to add the LED current-limiting resistor RL1 LED indicator option 'L' which is 1.5K Ohms.

3) Note that in both cases the total value of the series resistors and if fitted RL1 will impact the brightness of the LED.

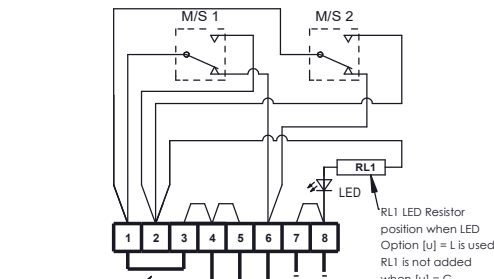

**Circuit shown in Unoperated condition**

**Unoperated condition (Glass Intact / Standby Condition)**  
Terminals +(4,5) & -(7,8) open  
Terminals +(4,5) & (6) closed

**Operated condition (Glass Broken / Button pushed in)**  
Terminals +(4,5) & -(7,8) closed  
Terminals +(4,5) & (6) open

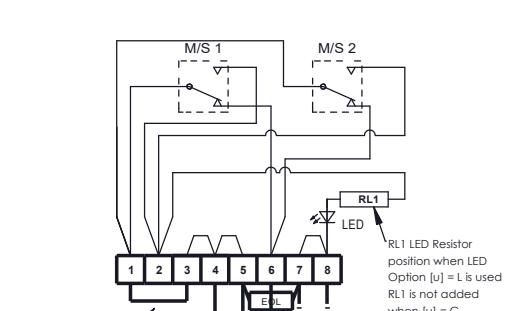
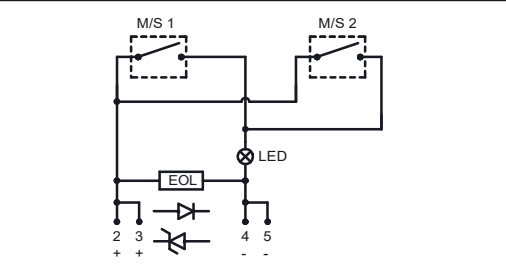

**Circuit shown in Unoperated condition**

**Unoperated condition (Glass Intact / Standby Condition)**  
Terminals +(4,5) & -(7,8) open  
Terminals +(4,5) & (6) closed

**Operated condition (Glass Broken / Button pushed in)**  
Terminals +(4,5) & -(7,8) closed  
Terminals +(4,5) & (6) open

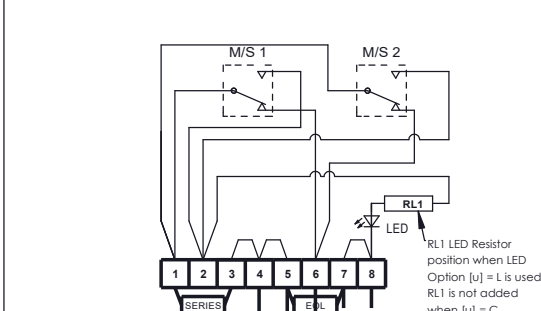
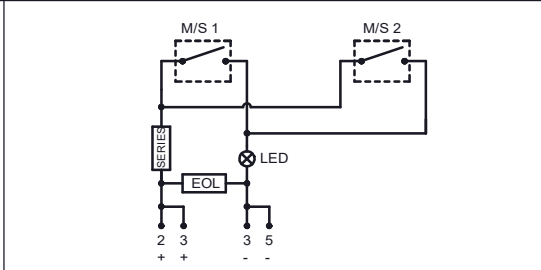

**Circuit shown in Unoperated condition**

**Unoperated condition (Glass Intact / Standby Condition)**  
Terminals +(4,5) & -(7,8) open  
Terminals +(4,5) & (6) closed

**Operated condition (Glass Broken / Button pushed in)**  
Terminals +(4,5) & -(7,8) closed  
Terminals +(4,5) & (6) open

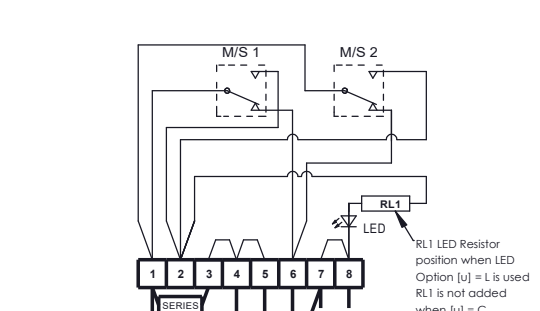
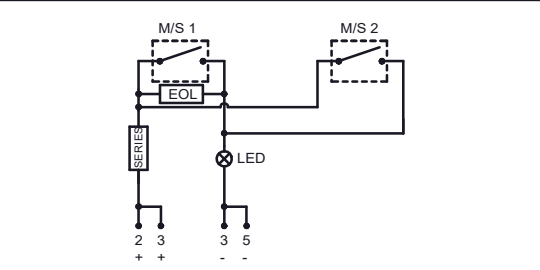

**Circuit shown in Unoperated condition**

**Unoperated condition (Glass Intact / Standby Condition)**  
Terminals +(4,5) & -(7,8) open  
Terminals +(4,5) & (6) closed

**Operated condition (Glass Broken / Button pushed in)**  
Terminals +(4,5) & -(7,8) closed  
Terminals +(4,5) & (6) open

DRAWING TO BS8888:2000  
GEOMETRIC TOLERANCES TO ISO1101:1983  
LINEAR DIMENSIONAL TOLS  
ANGULAR DIMENSIONAL TOLS

STANDARDS  
**GNExCP7 ; STExCP8 ; WP7 units with DIN Rail**

DRAWN	DATE
D.HOWGILL	05-03-2020
CHECKED	DATE
R.N.POTTS	05-03-2020
APPROVED	DATE
R.N.POTTS	05-03-2020

SURFACE FINISH	WEIGHT (Kg)
MATERIAL	
ALTERNATIVE MATERIAL	

THIS DRAWING AND ANY INFORMATION OR DESCRIPTIVE MATTER THEREIN IS COMMUNICATED IN CONFIDENCE AND IS THE COPYRIGHT PROPERTY OF EUROPEAN SAFETY SYSTEMS LTD. NEITHER THE WHOLE OR ANY EXTRACT MAY BE DISCLOSED, LOANED, COPIED OR USED FOR MANUFACTURING OR TENDERING PURPOSES WITHOUT THEIR WRITTEN CONSENT.

EUROPEAN SAFETY SYSTEMS LTD.  
AS PER LATEST DATE OF ISSUE SHOWN ABOVE

EUROPEAN SAFETY SYSTEMS LTD  
IMPRESS HOUSE  
MANSELL ROAD  
ACTON  
LONDON W3 7QH  
WWW.E2S.COM

ALL DIMENSIONS IN MM IF IN DOUBT, ASK - DO NOT SCALE				<b>A3</b>
TITLE <b>GNExCP7 ; STExCP8 ; WP7 CALL POINT WIRING / CIRCUIT OPERATION DIAGRAM</b>				
SCALE	SHEET	DRAWING NUMBER		
NTS	8 OF 8	<b>D202-06-211</b>		

**SINGLE MICROSWITCH DEVICES**

**SHEET 1**

**Module Device Codes**

PRODUCTS:  
GNExCP7, STExCP8  
& WP7

Diagram	Sheet
Dual Switch Wiring Configurations	2,3,5,6,7,8
LED Indicator Wiring Configurations	4,5,6,8
Parallel Dual Switch Wiring Configurations	7,8

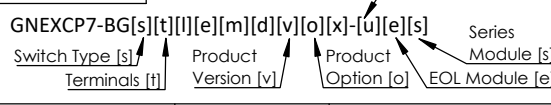

	EOL	Series
Resistor	ExxxR	SxxxR
Diode	ED1	SD1
Zener Diode	ExxxZ	SxxxZ
LED	N/A	L or C

ISSUE	MOD No.	REASON - INITIAL - DATE
1	ACN0127	Addition of LED version ; Options clarified RNP 20-08-2023
2	ACN0178	LED C and L version clarified ; LED mounted in N/O position on switch RNP 04-04-2025

SINGLE SWITCH	CONFIG. P1 -1	SINGLE SWITCH WITH SERIES DEVICE	CONFIG. P1-2	SINGLE SWITCH WITH EOL & SERIES DEVICES	CONFIG. P1-3	SINGLE SWITCH WITH EOL & ALT SERIES DEVICES	CONFIG. P1-4
---------------	---------------	----------------------------------	--------------	---	--------------	---	--------------

SWITCH TYPE [s] TERMINALS [t] PRODUCT OPTION [o] LED INDICATOR [u]	[S] [P] [1] [N]	Single PCB Version Default NO LED	SWITCH TYPE [s] TERMINALS [t] PRODUCT OPTION [o] LED INDICATOR [u] EOL MODULE [e]	[S] [P] [1] [N] [Exxxx]	Single PCB Version Default NO LED EOL Device	SWITCH TYPE [s] TERMINALS [t] PRODUCT OPTION [o] LED INDICATOR [u] MODULES [e][s]	[S] [P] [1] [N] [Exxxx][Sxxxx]	Single PCB Version Default NO LED EOL + Series	SWITCH TYPE [s] TERMINALS [t] PRODUCT OPTION [o] LED INDICATOR [u] MODULE [e][s]	[S] [P] [W] [N] [Exxxx][Sxxxx]	Single PCB Version Alt. EOL Pos'n. NO LED EOL + Series
---	--------------------------	--	---	-------------------------------------	--	---	--	--	--	--	--

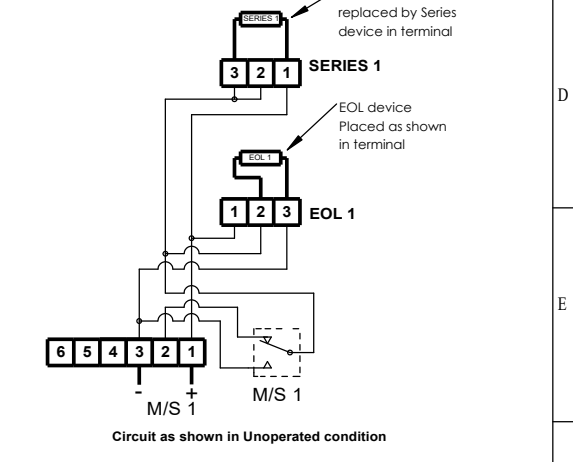
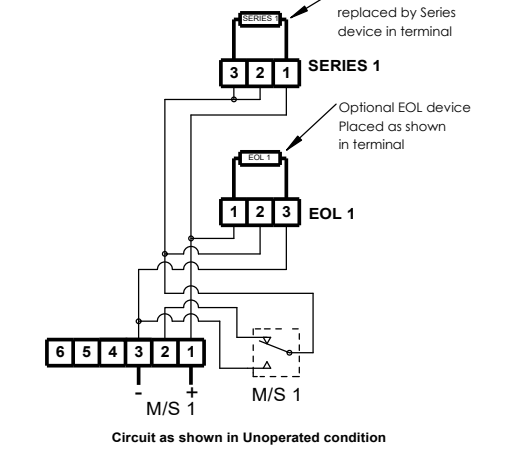
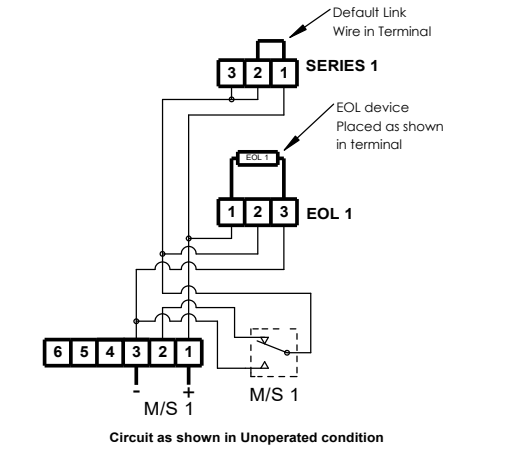
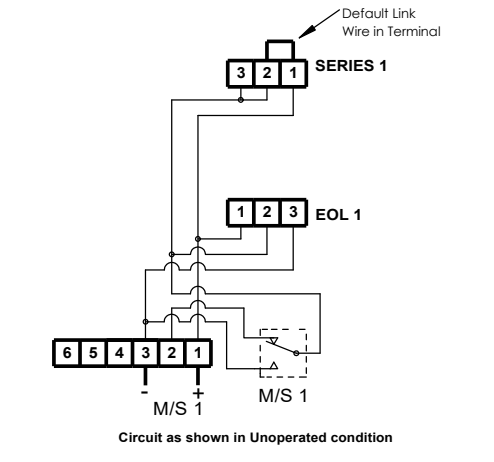
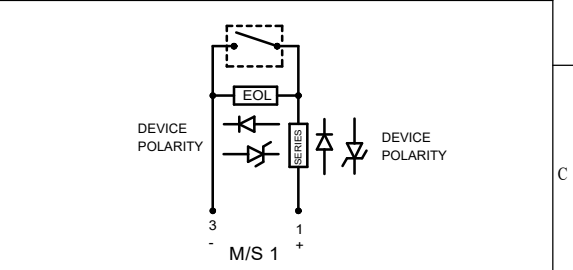
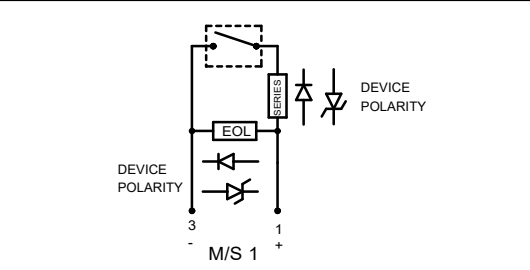
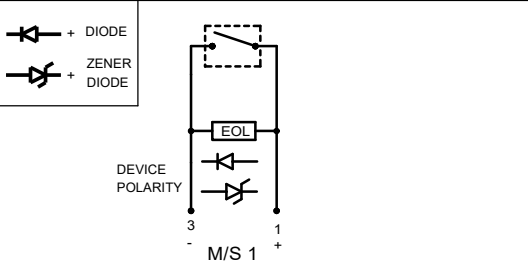
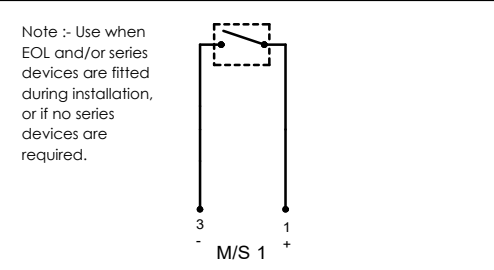

**Circuit as shown in Unoperated condition**

**Unoperated Condition (Glass Intact / Standby Condition)**  
Terminals +(1) & -(3) M/S 1 open  
Terminals +(1) & (2) M/S 1 closed

**Operated Condition (Glass Broken / Button pushes in)**  
Terminals +(1) & (2) M/S 1 open  
Terminals +(1) & -(3) M/S 1 closed

**Circuit as shown in Unoperated condition**

**Unoperated Condition (Glass Intact / Standby Condition)**  
Terminals +(1) & -(3) M/S 1 open  
Terminals -(1) & (2) M/S 1 closed

**Operated Condition (Glass Broken / Button pushes in)**  
Terminals +(1) & (2) M/S 1 open  
Terminals +(1) & -(3) M/S 1 closed

**Circuit as shown in Unoperated condition**

**Unoperated Condition (Glass Intact / Standby Condition)**  
Terminals +(1) & -(3) M/S 1 open  
Terminals +(1) & (2) M/S 1 closed

**Operated Condition (Glass Broken / Button pushes in)**  
Terminals +(1) & (2) M/S 1 open  
Terminals +(1) & -(3) M/S 1 closed

**Circuit as shown in Unoperated condition**

**Unoperated Condition (Glass Intact / Standby Condition)**  
Terminals +(1) & -(3) M/S 1 open  
Terminals +(1) & (2) M/S 1 closed

**Operated Condition (Glass Broken / Button pushes in)**  
Terminals +(1) & (2) M/S 1 open  
Terminals +(1) & -(3) M/S 1 closed

DRAWING TO BS8888:2000  
GEOMETRIC TOLERANCES TO ISO1101:1983  
LINEAR DIMENSIONAL TOLS  
ANGULAR DIMENSIONAL TOLS

STANDARDS  
GNExCP7 ; STExCP8 ; WP7 units  
with PCB

DRAWN	DATE
R.N.POTTS	20-08-2023
CHECKED	DATE
B.ISARD	20-08-2023
APPROVED	DATE
R.N.POTTS	20-08-2023

SURFACE FINISH	WEIGHT (Kg)
MATERIAL	
ALTERNATIVE MATERIAL	

THIS DRAWING AND ANY INFORMATION OR DESCRIPTIVE MATTER THEREIN IS COMMUNICATED IN CONFIDENCE AND IS THE COPYRIGHT PROPERTY OF EUROPEAN SAFETY SYSTEMS LTD. NEITHER THE WHOLE OR ANY EXTRACT MAY BE DISCLOSED, LOANED, COPIED OR USED FOR MANUFACTURING OR TENDERING PURPOSES WITHOUT THEIR WRITTEN CONSENT.

EUROPEAN SAFETY SYSTEMS LTD.  
AS PER LATEST DATE OF ISSUE SHOWN ABOVE

EUROPEAN SAFETY SYSTEMS LTD  
IMPRESS HOUSE  
MANSELL ROAD  
ACTON  
LONDON W3 7QH  
WWW.E2S.COM

ALL DIMENSIONS IN MM IF IN DOUBT, ASK - DO NOT SCALE			<b>A3</b>
TITLE <b>GNExCP7 ; STExCP8 ; WP7 CALL POINT WIRING / CIRCUIT OPERATION DIAGRAM</b>			
SCALE	SHEET	DRAWING NUMBER	
NTS	1 OF 8	<b>D202-06-212</b>	

**DUAL MICROSWITCH DEVICES**

**SHEET 2**

**Module Device Codes**

	EOL	Series
Resistor	ExxxR	SxxxR
Diode	ED1	SD1
Zener Diode	ExxxZ	SxxxZ
LED	N/A	L or C

ISSUE	MOD No.	REASON - INITIAL - DATE
1	ACN0127	INTRODUCTION RNP 20-08-2023
2	ACN0178	LED C and L version clarified ; LED mounted in N/O position on switch RNP 04-04-2025

Notes:  
1. Other configurations of dual switch units are possible. Contact E2S sales to discuss options.

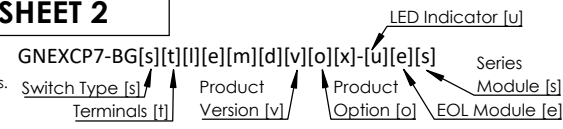

<b>DUAL SWITCH</b>	<b>CONFIG. P2-1</b>	<b>DUAL SWITCH WITH EOL &amp; SERIES DEVICES</b>	<b>CONFIG. P2-2</b>	<b>DUAL SWITCH WITH EOL &amp; ALT. SERIES DEVICES</b>	<b>CONFIG. P2-3</b>
--------------------	---------------------	--	---------------------	---	---------------------

SWITCH TYPE [s] [D] TERMINALS [t] [P] PRODUCT OPTION [o] [1] LED INDICATOR [u] [N]	Dual PCB Version Default NO LED	SWITCH TYPE [s] [D] TERMINALS [t] [P] PRODUCT OPTION [o] [1] LED INDICATOR [u] [N] MODULES [e][s] [Exxxx][Sxxxx]	Dual PCB Version Default No LED EOL + Series	SWITCH TYPE [s] [D] TERMINALS [t] [P] PRODUCT OPTION [o] [W] LED INDICATOR [u] [N] MODULES [e][s] [Exxxx][Sxxxx]	Dual PCB Version Alt. EOL Pos'n. No LED EOL + Series
---	---------------------------------------	--	---	--	---

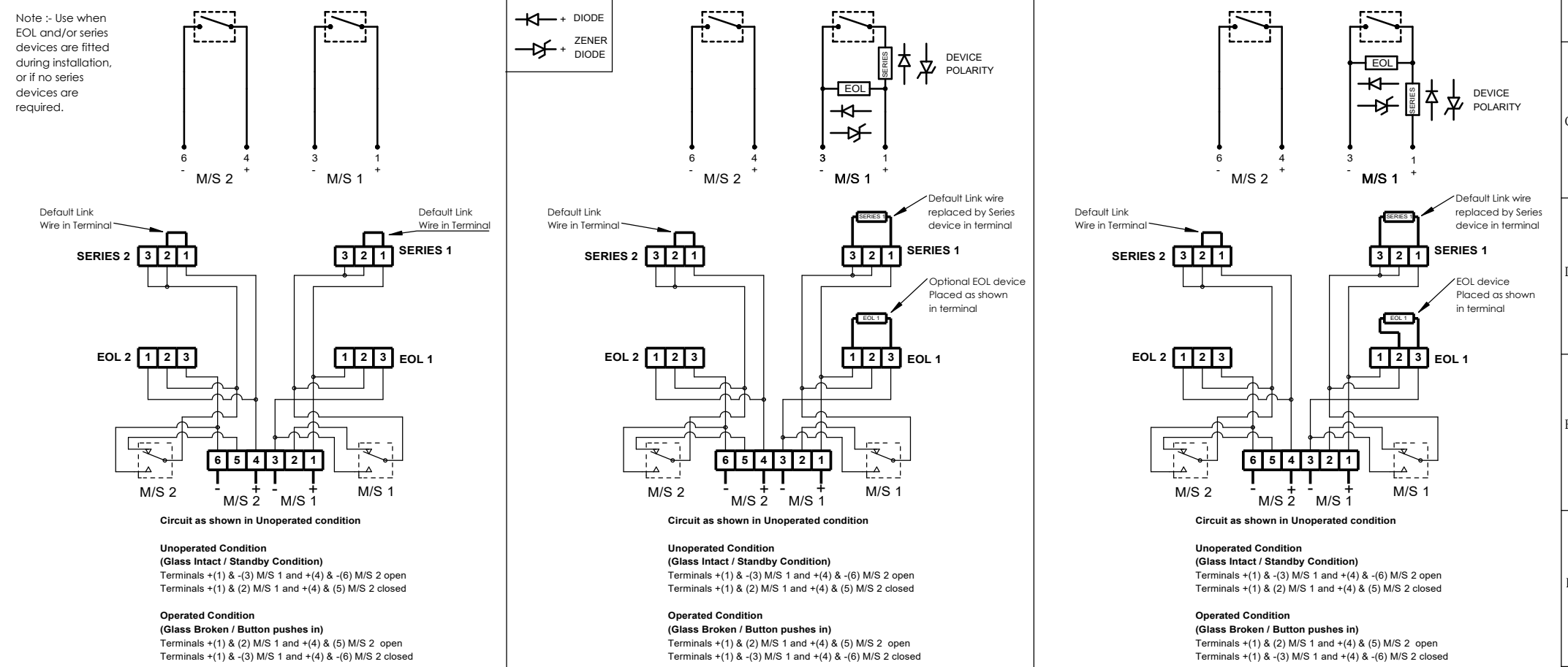

DRAWING TO BS8888:2000 GEOMETRIC TOLERANCES TO ISO1101:1983 LINEAR DIMENSIONAL TOLS ANGULAR DIMENSIONAL TOLS	DRAWN R.N.POTTS DATE 20-08-2023 CHECKED B.ISARD DATE 20-08-2023 APPROVED R.N.POTTS DATE 20-08-2023	SURFACE FINISH MATERIAL ALTERNATIVE MATERIAL	WEIGHT (Kg)	THIS DRAWING AND ANY INFORMATION OR DESCRIPTIVE MATTER THEREIN IS COMMUNICATED IN CONFIDENCE AND IS THE COPYRIGHT PROPERTY OF EUROPEAN SAFETY SYSTEMS LTD. NEITHER THE WHOLE OR ANY EXTRACT MAY BE DISCLOSED, LOANED, COPIED OR USED FOR MANUFACTURING OR TENDERING PURPOSES WITHOUT THEIR WRITTEN CONSENT. EUROPEAN SAFETY SYSTEMS LTD. AS PER LATEST DATE OF ISSUE SHOWN ABOVE	warning signals EUROPEAN SAFETY SYSTEMS LTD IMPRESS HOUSE MANSELL ROAD ACTON LONDON W3 7QH WWW.E2S.COM	ALL DIMENSIONS IN MM IF IN DOUBT, ASK - DO NOT SCALE TITLE <b>GNEXCP7 ; STExCP8 ; WP7 CALL POINT WIRING / CIRCUIT OPERATION DIAGRAM</b> SCALE NTS SHEET 2 OF 8 DRAWING NUMBER <b>D202-06-212</b>
---	--	--	-------------	--	--	---

**DUAL MICROSWITCH DEVICES DUPLICATED**

**SHEET 3**

**Module Device Codes**

	EOL	Series
Resistor	ExxxR	SxxxR
Diode	ED1	SD1
Zener Diode	ExxxZ	SxxxZ
LED	N/A	L or C

ISSUE	MOD No.	REASON - INITIAL - DATE
1	ACN0127	INTRODUCTION RNP 20-08-2023
2	ACN0178	LED C and L version clarified ; LED mounted in N/O position on switch RNP 04-04-2025

Notes:  
1. Other configurations of dual switch units are possible. Contact E2S sales to discuss options.

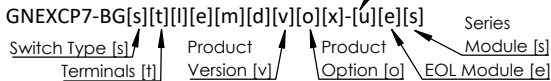

**DUAL SWITCH WITH EOL & SERIES DEVICES DUPLICATED**

CONFIG. P3-1

**DUAL SWITCH WITH EOL & ALT. SERIES DEVICES DUPLICATED**

CONFIG. P3-2

SWITCH TYPE [s] [D] Dual  
 TERMINALS [t] [P] PCB Version  
 PRODUCT OPTION [o] [2] Duplicate EOL/Series  
 LED INDICATOR [u] [N] No LED  
 MODULES [e][s] [Exxxx][Sxxxx] EOL + Series

SWITCH TYPE [s] [D] Dual  
 TERMINALS [t] [P] PCB Version  
 PRODUCT OPTION [o] [Y] Alt. EOL Pos'n, duplicated  
 LED INDICATOR [u] [N] No LED  
 MODULES [e][s] [Exxxx][Sxxxx] EOL + Series

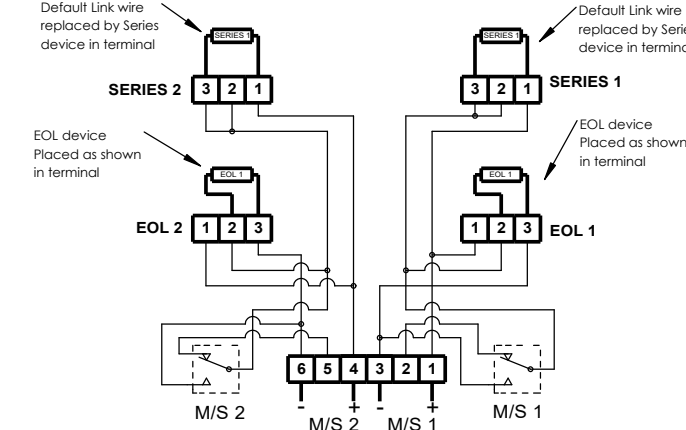
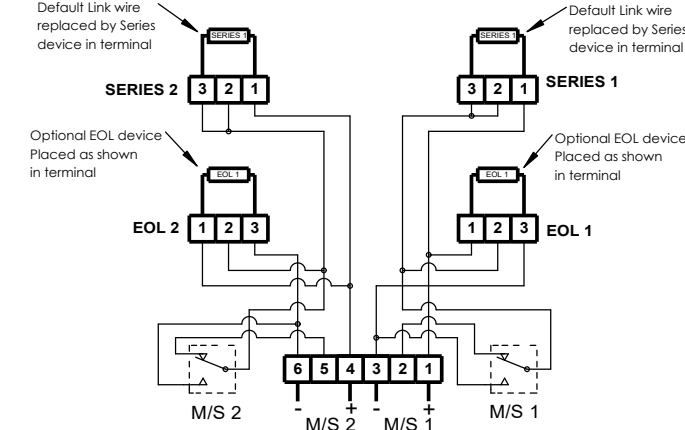
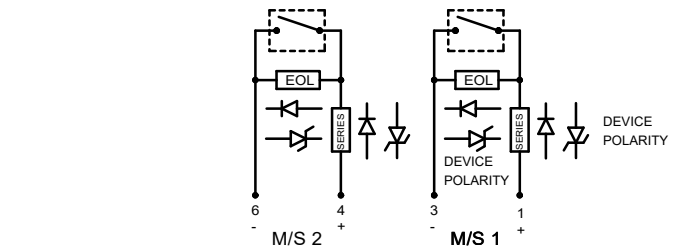
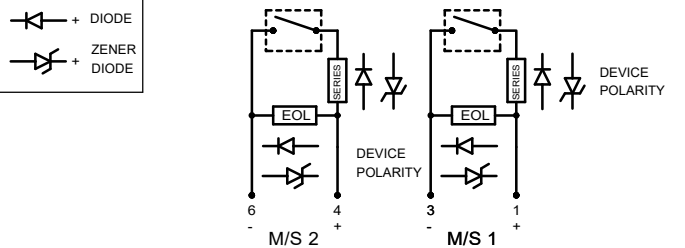

**Circuit as shown in Unoperated condition**

**Unoperated Condition (Glass Intact / Standby Condition)**  
 Terminals +(1) & -(3) M/S 1 and +(4) & -(6) M/S 2 open  
 Terminals +(1) & (2) M/S 1 and +(4) & (5) M/S 2 closed

**Operated Condition (Glass Broken / Button pushes in)**  
 Terminals +(1) & (2) M/S 1 and +(4) & (5) M/S 2 open  
 Terminals +(1) & -(3) M/S 1 and +(4) & -(6) M/S 2 closed

**Circuit as shown in Unoperated condition**

**Unoperated Condition (Glass Intact / Standby Condition)**  
 Terminals +(1) & -(3) M/S 1 and +(4) & -(6) M/S 2 open  
 Terminals +(1) & (2) M/S 1 and +(4) & (5) M/S 2 closed

**Operated Condition (Glass Broken / Button pushes in)**  
 Terminals +(1) & (2) M/S 1 and +(4) & (5) M/S 2 open  
 Terminals +(1) & -(3) M/S 1 and +(4) & -(6) M/S 2 closed

DRAWING TO BS8888:2000  
 GEOMETRIC TOLERANCES TO ISO1101:1983  
 LINEAR DIMENSIONAL TOLS  
 ANGULAR DIMENSIONAL TOLS

STANDARDS  
 GNEXCP7 ; STEXCP8 ; WP7 units  
 with PCB

DRAWN	DATE
R.N.POTTS	20-08-2023
CHECKED	DATE
B.ISARD	20-08-2023
APPROVED	DATE
R.N.POTTS	20-08-2023

SURFACE FINISH	WEIGHT (Kg)
MATERIAL	
ALTERNATIVE MATERIAL	

THIS DRAWING AND ANY INFORMATION OR DESCRIPTIVE MATTER THEREIN IS COMMUNICATED IN CONFIDENCE AND IS THE COPYRIGHT PROPERTY OF EUROPEAN SAFETY SYSTEMS LTD. NEITHER THE WHOLE OR ANY EXTRACT MAY BE DISCLOSED, LOANED, COPIED OR USED FOR MANUFACTURING OR TENDERING PURPOSES WITHOUT THEIR WRITTEN CONSENT.

EUROPEAN SAFETY SYSTEMS LTD.  
 AS PER LATEST DATE OF ISSUE SHOWN ABOVE

EUROPEAN SAFETY SYSTEMS LTD  
 IMPRESS HOUSE  
 MANSSELL ROAD  
 ACTON  
 LONDON W3 7QH  
 WWW.E2S.COM

ALL DIMENSIONS IN MM  
 IF IN DOUBT, ASK -  
 DO NOT SCALE

**A3**

**TITLE GNEXCP7 ; STEXCP8 ; WP7 CALL POINT WIRING / CIRCUIT OPERATION DIAGRAM**

SCALE	SHEET	DRAWING NUMBER
NTS	3 OF 8	<b>D202-06-212</b>

**SINGLE MICROSWITCH LED DEVICES**

**SHEET 4**

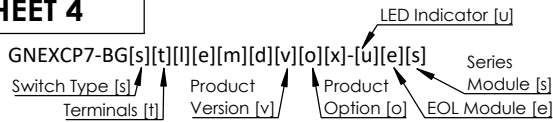

Module Device Codes		
	EOL	Series
Resistor	ExxxR	SxxxR
Diode	ED1	SD1
Zener Diode	ExxxZ	SxxxZ
LED	N/A	L or C

ISSUE	MOD No.	REASON - INITIAL - DATE
1	ACN0127	Addition of LED version ; Options clarified RNP 20-08-2023
2	ACN0178	LED C and L version clarified ; LED mounted in N/O position on switch RNP 04-04-2025

SINGLE SWITCH	CONFIG. P4-1	SINGLE SWITCH WITH SERIES DEVICES	CONFIG. P4-2	SINGLE SWITCH WITH EOL & SERIES DEVICES	CONFIG. P4-3	SINGLE SWITCH WITH EOL & ALT SERIES DEVICES	CONFIG. P4-4
---------------	--------------	-----------------------------------	--------------	---	--------------	---	--------------

SWITCH TYPE [s] TERMINALS [t] PRODUCT OPTION [o] LED INDICATOR [u]	[S] [P] [1] [L]	Single PCB Version Default LED with RL1	SWITCH TYPE [s] TERMINALS [t] PRODUCT OPTION [o] LED INDICATOR [u] EOL MODULE [e]	[S] [P] [1] [L] [Exxxx]	Single PCB Version Default LED with RL1 EOL Device	SWITCH TYPE [s] TERMINALS [t] PRODUCT OPTION [o] LED INDICATOR [u] MODULES [e][s]	[S] [P] [1] [L] [Exxxx][Sxxxx]	Single PCB Version Default LED with RL1 EOL + Series	SWITCH TYPE [s] TERMINALS [t] PRODUCT OPTION [o] LED INDICATOR [u] MODULE [e][s]	[S] [P] [W] [L] [Exxxx][Sxxxx]	Single PCB Version Alt. EOL Pos'n. LED with RL1 EOL + Series
---	--------------------------	--	---	-------------------------------------	--	---	--	--	--	--	--

Notes - For all LED Options:

- The LED is configured as LED indicator option 'C' for this version the LED must be protected by a series resistor of a minimum value of 1.5K Ohm or by limiting the systems current to 20mA max
- Units have the option to add the LED current-limiting resistor RL1 LED indicator option 'L' which is 1.5K Ohms.
- Note that in both cases the total value of the series resistors and if fitted RL1 will impact the brightness of the LED.

**Circuit as shown in Unoperated condition**  
**Unoperated Condition (Glass Intact / Standby Condition)**  
 Terminals +(1) & -(3) M/S 1 open  
 Terminals +(1) & (2) M/S 1 closed

**Operated Condition (Glass Broken / Button pushes in)**  
 Terminals +(1) & (2) M/S 1 open  
 Terminals +(1) & -(3) M/S 1 closed

**Circuit as shown in Unoperated condition**  
**Unoperated Condition (Glass Intact / Standby Condition)**  
 Terminals +(1) & -(3) M/S 1 open  
 Terminals +(1) & (2) M/S 1 closed

**Operated Condition (Glass Broken / Button pushes in)**  
 Terminals +(1) & (2) M/S 1 open  
 Terminals +(1) & -(3) M/S 1 closed

**Circuit as shown in Unoperated condition**  
**Unoperated Condition (Glass Intact / Standby Condition)**  
 Terminals +(1) & -(3) M/S 1 open  
 Terminals +(1) & (2) M/S 1 closed

**Operated Condition (Glass Broken / Button pushes in)**  
 Terminals +(1) & (2) M/S 1 open  
 Terminals +(1) & -(3) M/S 1 closed

**Circuit as shown in Unoperated condition**  
**Unoperated Condition (Glass Intact / Standby Condition)**  
 Terminals +(1) & -(3) M/S 1 open  
 Terminals +(1) & (2) M/S 1 closed

**Operated Condition (Glass Broken / Button pushes in)**  
 Terminals +(1) & (2) M/S 1 open  
 Terminals +(1) & -(3) M/S 1 closed

DRAWING TO BS8888:2000 GEOMETRIC TOLERANCES TO ISO1101:1983 LINEAR DIMENSIONAL TOLS ANGULAR DIMENSIONAL TOLS	DRAWN	DATE	SURFACE FINISH	WEIGHT (Kg)
	R.N.POTTS	20-08-2023		
	CHECKED	DATE		
STANDARDS GNEXCP7 ; STExCP8 ; WP7 units with PCB	B.ISARD	20-08-2023	ALTERNATIVE MATERIAL	
	APPROVED	DATE		
	R.N.POTTS	20-08-2023		

THIS DRAWING AND ANY INFORMATION OR DESCRIPTIVE MATTER THEREIN IS COMMUNICATED IN CONFIDENCE AND IS THE COPYRIGHT PROPERTY OF EUROPEAN SAFETY SYSTEMS LTD. NEITHER THE WHOLE OR ANY EXTRACT MAY BE DISCLOSED, LOANED, COPIED OR USED FOR MANUFACTURING OR TENDERING PURPOSES WITHOUT THEIR WRITTEN CONSENT.

EUROPEAN SAFETY SYSTEMS LTD.  
AS PER LATEST DATE OF ISSUE SHOWN ABOVE

EUROPEAN SAFETY SYSTEMS LTD  
IMPRESS HOUSE  
MANSELL ROAD  
ACTON  
LONDON W3 7QH  
WWW.E2S.COM

ALL DIMENSIONS IN MM IF IN DOUBT, ASK - DO NOT SCALE				<b>A3</b>
TITLE <b>GNEXCP7 ; STExCP8 ; WP7 CALL POINT WIRING / CIRCUIT OPERATION DIAGRAM</b>				
SCALE	SHEET	DRAWING NUMBER		
NTS	4 OF 8	<b>D202-06-212</b>		

**DUAL MICROSWITCH LED DEVICES**

**SHEET 5**

GNEXCP7-BG[s][t][l][e][m][d][v][o][x]-[u][e][s]  
 Switch Type [s] Terminals [t] Product Version [v] Product Option [o] LED Indicator [u] Series Module [s] EOL Module [e]

Module Device Codes		
	EOL	Series
Resistor	ExxxR	SxxxR
Diode	ED1	SD1
Zener Diode	ExxxZ	SxxxZ
LED	N/A	L or C

ISSUE	MOD No.	REASON - INITIAL - DATE
1	ACN0127	INTRODUCTION RNP 20-08-2023
2	ACN0178	LED C and L version clarified ; LED mounted in N/O position on switch RNP 04-04-2025

**DUAL SWITCH WITH LED**

CONFIG. P5-1

**DUAL SWITCH WITH LED, EOL & SERIES DEVICES**

CONFIG. P5-2

**DUAL SWITCH WITH LED, EOL & ALT. SERIES DEVICES**

CONFIG. P5-3

SWITCH TYPE [s] [D]  
 TERMINALS [t] [P]  
 PRODUCT OPTION [o] [1]  
 LED INDICATOR [u] [C] or [L]  
 PCB Version  
 Default  
 C = LED without RL1

SWITCH TYPE [s] [D]  
 TERMINALS [t] [P]  
 PRODUCT OPTION [o] [1]  
 LED INDICATOR [u] [C] or [L]  
 MODULES [e][s] [Exxxx][Sxxxx]  
 PCB Version  
 Default  
 C = LED without RL1  
 EOL + Series

SWITCH TYPE [s] [D]  
 TERMINALS [t] [P]  
 PRODUCT OPTION [o] [W]  
 LED INDICATOR [u] [C] or [L]  
 MODULES [e][s] [Exxxx][Sxxxx]  
 PCB Version  
 Alt. EOL Pos'n.  
 C = LED without RL1  
 EOL + Series

Notes - For all LED Options:

1) The LED is configured as LED indicator option 'C' for this version the LED must be protected by a series resistor of a minimum value of 1.5K Ohm or by limiting the systems current to 20mA max

2) Units have the option to add the LED current-limiting resistor RL1 LED indicator option 'L' which is 1.5K Ohms.

3) Note that in both cases the total value of the series resistors and if fitted RL1 will impact the brightness of the LED.

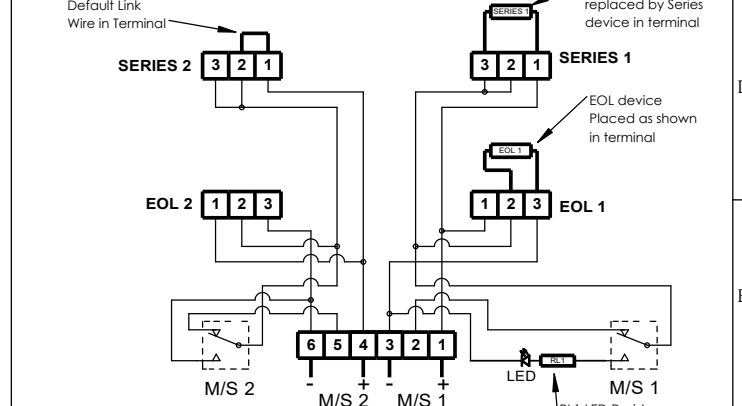
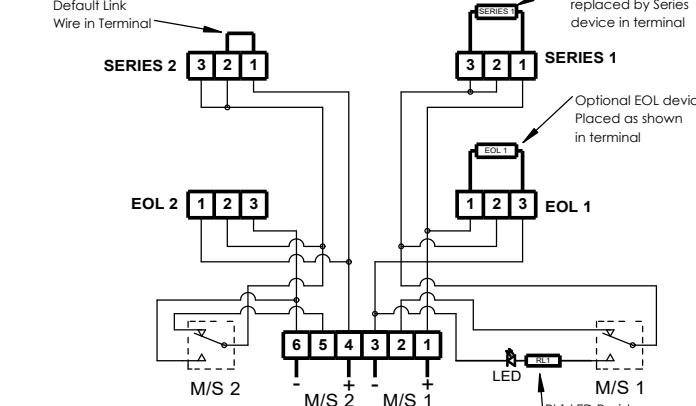
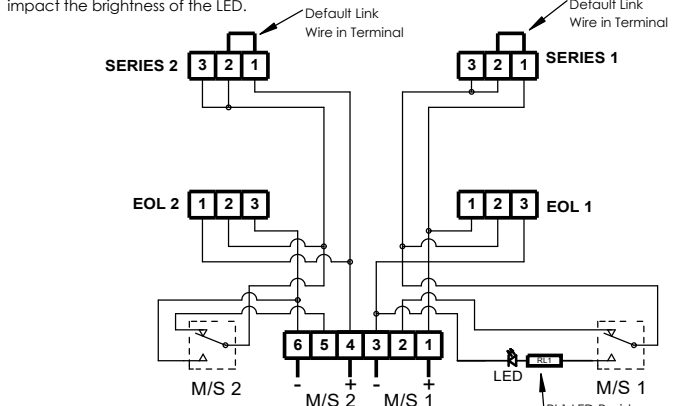
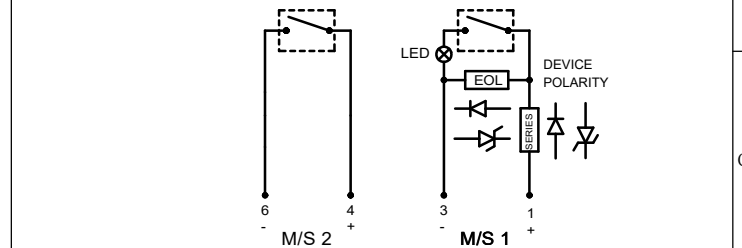
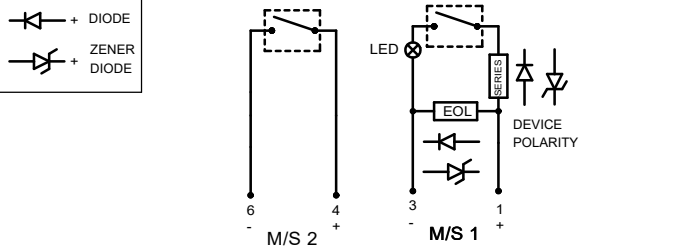
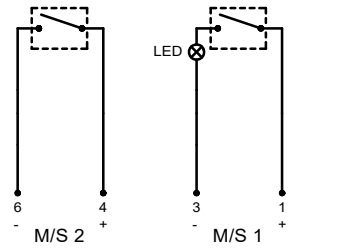

**Circuit as shown in Unoperated condition**

**Unoperated Condition (Glass Intact / Standby Condition)**  
 Terminals +(1) & -(3) M/S 1 and +(4) & -(6) M/S 2 open  
 Terminals +(1) & (2) M/S 1 and +(4) & (5) M/S 2 closed

**Operated Condition (Glass Broken / Button pushes in)**  
 Terminals +(1) & (2) M/S 1 and +(4) & (5) M/S 2 open  
 Terminals +(1) & -(3) M/S 1 and +(4) & -(6) M/S 2 closed

**Circuit as shown in Unoperated condition**

**Unoperated Condition (Glass Intact / Standby Condition)**  
 Terminals +(1) & -(3) M/S 1 and +(4) & -(6) M/S 2 open  
 Terminals +(1) & (2) M/S 1 and +(4) & (5) M/S 2 closed

**Operated Condition (Glass Broken / Button pushes in)**  
 Terminals +(1) & (2) M/S 1 and +(4) & (5) M/S 2 open  
 Terminals +(1) & -(3) M/S 1 and +(4) & -(6) M/S 2 closed

**Circuit as shown in Unoperated condition**

**Unoperated Condition (Glass Intact / Standby Condition)**  
 Terminals +(1) & -(3) M/S 1 and +(4) & -(6) M/S 2 open  
 Terminals +(1) & (2) M/S 1 and +(4) & (5) M/S 2 closed

**Operated Condition (Glass Broken / Button pushes in)**  
 Terminals +(1) & (2) M/S 1 and +(4) & (5) M/S 2 open  
 Terminals +(1) & -(3) M/S 1 and +(4) & -(6) M/S 2 closed

DRAWING TO BS8888:2000  
 GEOMETRIC TOLERANCES TO ISO1101:1983  
 LINEAR DIMENSIONAL TOLS  
 ANGULAR DIMENSIONAL TOLS

STANDARDS  
 GNEXCP7 ; STExCP8 ; WP7 units  
 with PCB

DRAWN	DATE
R.N.POTTS	20-08-2023
CHECKED	DATE
B.ISARD	20-08-2023
APPROVED	DATE
R.N.POTTS	20-08-2023

SURFACE FINISH

WEIGHT (Kg)

MATERIAL

ALTERNATIVE MATERIAL

THIS DRAWING AND ANY INFORMATION OR DESCRIPTIVE MATTER THEREIN IS COMMUNICATED IN CONFIDENCE AND IS THE COPYRIGHT PROPERTY OF EUROPEAN SAFETY SYSTEMS LTD. NEITHER THE WHOLE OR ANY EXTRACT MAY BE DISCLOSED, LOANED, COPIED OR USED FOR MANUFACTURING OR TENDERING PURPOSES WITHOUT THEIR WRITTEN CONSENT.

EUROPEAN SAFETY SYSTEMS LTD.  
 AS PER LATEST DATE OF ISSUE SHOWN ABOVE

**e2s**  
 warning signals

EUROPEAN SAFETY SYSTEMS LTD  
 IMPRESS HOUSE  
 MANSELL ROAD  
 ACTON  
 LONDON W3 7QH  
 WWW.E2S.COM

ALL DIMENSIONS IN MM  
 IF IN DOUBT, ASK -  
 DO NOT SCALE

**A3**

TITLE **GNEXCP7 ; STExCP8 ; WP7 CALL POINT WIRING / CIRCUIT OPERATION DIAGRAM**

SCALE	SHEET	DRAWING NUMBER
NTS	5 OF 8	<b>D202-06-212</b>

**DUAL MICROSWITCH LED & DEVICES DUPLICATED**

**SHEET 6**

**Module Device Codes**

	EOL	Series
Resistor	ExxxR	SxxxR
Diode	ED1	SD1
Zener Diode	ExxxZ	SxxxZ
LED	N/A	L or C

ISSUE	MOD No.	REASON - INITIAL - DATE
1	ACN0127	INTRODUCTION RNP 20-08-2023
2	ACN0178	LED C and L version clarified ; LED mounted in N/O position on switch RNP 04-04-2025

GNEXCP7-BG[s][t][l][e][m][d][v][o][x]-[u][e][s]  
 Switch Type [s] Terminals [t] Product Version [v] Product Option [o] LED Indicator [u] Series Module [s] EOL Module [e]

**DUAL SWITCH WITH LED, EOL & SERIES DEVICES DUPLICATED**

**CONFIG. P6-1**

**DUAL SWITCH WITH LED, EOL & ALT. SERIES DEVICES DUPLICATED**

**CONFIG. P6-2**

SWITCH TYPE [s] [D]  
 TERMINALS [t] [P]  
 PRODUCT OPTION [o] [2]  
 LED INDICATOR [u] [C] or [L]  
 MODULES [e][s] [Exxxx][Sxxxx]

Dual PCB Version Duplicate EOL/Series C = LED without RL1 EOL + Series

SWITCH TYPE [s] [D]  
 TERMINALS [t] [P]  
 PRODUCT OPTION [o] [Y]  
 LED INDICATOR [u] [C] or [L]  
 MODULES [e][s] [Exxxx][Sxxxx]

Dual PCB Version Alt. EOL Pos'n duplicated C = LED without RL1 EOL + Series

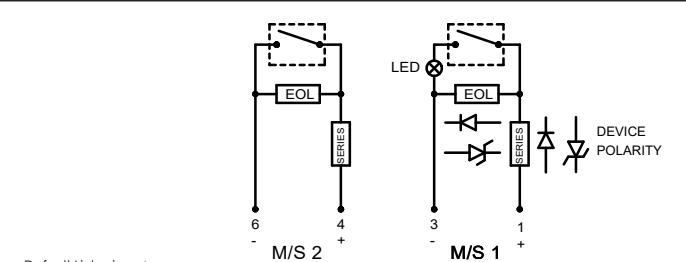
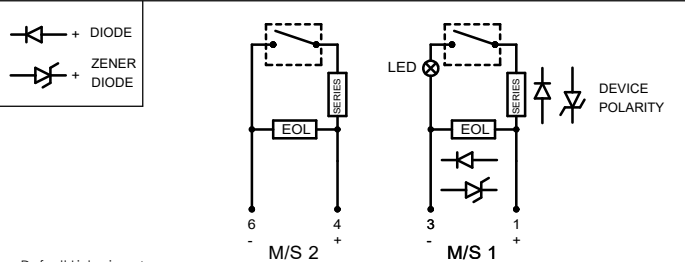

Notes - For all LED Options:

- 1) The LED is configured as LED indicator option 'C' for this version the LED must be protected by a series resistor of a minimum value of 1.5K Ohm or by limiting the systems current to 20mA max
- 2) Units have the option to add the LED current-limiting resistor RL1 LED indicator option 'L' which is 1.5K Ohms.
- 3) Note that in both cases the total value of the series resistors and if fitted RL1 will impact the brightness of the LED.

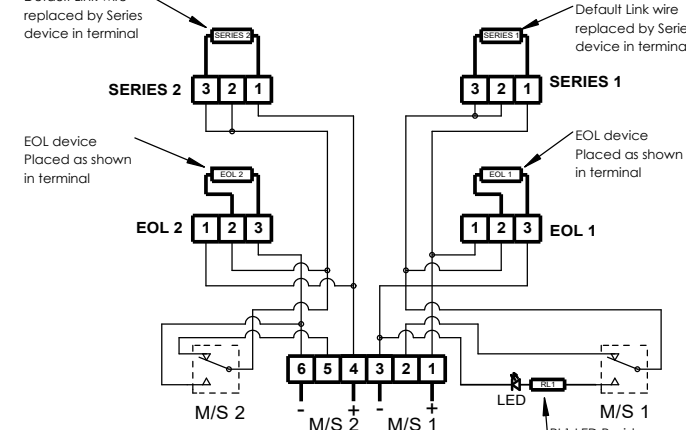
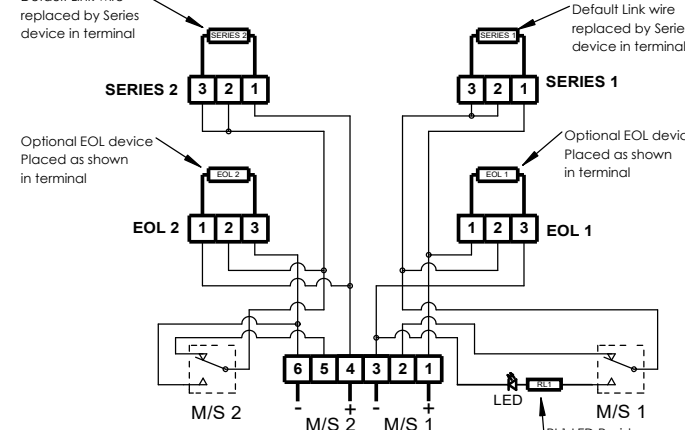

**Circuit as shown in Unoperated condition**

**Unoperated Condition (Glass Intact / Standby Condition)**  
 Terminals +(1) & -(3) M/S 1 and +(4) & -(6) M/S 2 open  
 Terminals +(1) & (2) M/S 1 and +(4) & (5) M/S 2 closed

**Operated Condition (Glass Broken / Button pushes in)**  
 Terminals +(1) & (2) M/S 1 and +(4) & (5) M/S 2 open  
 Terminals +(1) & -(3) M/S 1 and +(4) & -(6) M/S 2 closed

**Circuit as shown in Unoperated condition**

**Unoperated Condition (Glass Intact / Standby Condition)**  
 Terminals +(1) & -(3) M/S 1 and +(4) & -(6) M/S 2 open  
 Terminals +(1) & (2) M/S 1 and +(4) & (5) M/S 2 closed

**Operated Condition (Glass Broken / Button pushes in)**  
 Terminals +(1) & (2) M/S 1 and +(4) & (5) M/S 2 open  
 Terminals +(1) & -(3) M/S 1 and +(4) & -(6) M/S 2 closed

DRAWING TO BS8888:2000  
 GEOMETRIC TOLERANCES TO ISO1101:1983  
 LINEAR DIMENSIONAL TOLS  
 ANGULAR DIMENSIONAL TOLS

STANDARDS  
 GNEXCP7 ; STEXCP8 ; WP7 units with PCB

DRAWN	R.N.POTTS	DATE	20-08-2023
CHECKED	B.ISARD	DATE	20-08-2023
APPROVED	R.N.POTTS	DATE	20-08-2023

SURFACE FINISH

WEIGHT (Kg)

MATERIAL

ALTERNATIVE MATERIAL

THIS DRAWING AND ANY INFORMATION OR DESCRIPTIVE MATTER THEREIN IS COMMUNICATED IN CONFIDENCE AND IS THE COPYRIGHT PROPERTY OF EUROPEAN SAFETY SYSTEMS LTD. NEITHER THE WHOLE OR ANY EXTRACT MAY BE DISCLOSED, LOANED, COPIED OR USED FOR MANUFACTURING OR TENDERING PURPOSES WITHOUT THEIR WRITTEN CONSENT.

EUROPEAN SAFETY SYSTEMS LTD.  
 AS PER LATEST DATE OF ISSUE SHOWN ABOVE



ALL DIMENSIONS IN MM IF IN DOUBT, ASK - DO NOT SCALE			<b>A3</b>
TITLE <b>GNEXCP7 ; STEXCP8 ; WP7 CALL POINT WIRING / CIRCUIT OPERATION DIAGRAM</b>			
SCALE NTS	SHEET 6 OF 8	DRAWING NUMBER <b>D202-06-212</b>	

**DUAL MICROSWITCH IN PARALLEL, & DEVICES**

**SHEET 7**

GNEXCP7-BG[s][t][l][e][m][d][v][o][x]-[u][e][s]  
 Switch Type [s] Terminals [t] Product Version [v] Product Option [o] LED Indicator [u] Series Module [s] EOL Module [e]

Module Device Codes		
	EOL	Series
Resistor	ExxxR	SxxxR
Diode	ED1	SD1
Zener Diode	ExxxZ	SxxxZ
LED	N/A	L or C

ISSUE	MOD No.	REASON - INITIAL - DATE
1	ACN0127	INTRODUCTION RNP 20-08-2023
2	ACN0178	LED C and L version clarified ; LED mounted in N/O position on switch RNP 04-04-2025

**DUAL SWITCH PARALLEL**

CONFIG. P7-1

**DUAL SWITCH, PARALLEL WITH EOL & SERIES DEVICES**

CONFIG. P7-2

**DUAL SWITCH, PARALLEL WITH EOL & ALT. SERIES DEVICES**

CONFIG. P7-3

SWITCH TYPE [s] [D]  
 TERMINALS [t] [P]  
 PRODUCT OPTION [o] [P]  
 LED INDICATOR [u] [N]  
 Dual PCB Version  
 Parallel Wiring  
 No LED

SWITCH TYPE [s] [D]  
 TERMINALS [t] [P]  
 PRODUCT OPTION [o] [P]  
 LED INDICATOR [u] [N]  
 MODULES [e][s] [Exxxx][Sxxxx]  
 Dual PCB Version  
 Parallel Wiring  
 No LED  
 EOL + Series

SWITCH TYPE [s] [D]  
 TERMINALS [t] [P]  
 PRODUCT OPTION [o] [V]  
 LED INDICATOR [u] [N]  
 MODULES [e][s] [Exxxx][Sxxxx]  
 Dual PCB Version  
 Parallel Wiring Alt. EOL Pos'n.  
 No LED  
 EOL + Series

Note :- Use when EOL and/or series devices are fitted during installation, or if no series devices are required.

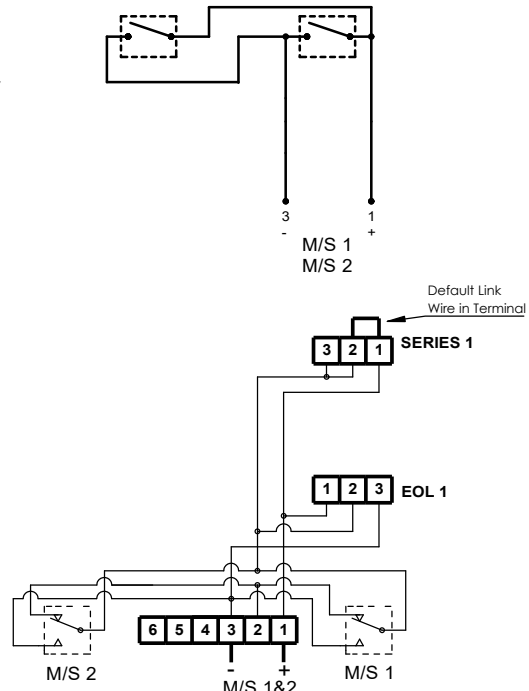

Circuit as shown in Unoperated condition

**Unoperated Condition (Glass Intact / Standby Condition)**  
 Terminals +(1) & -(3) M/S 1 and M/S 2 open  
 Terminals +(1) & (2) M/S 1 and M/S 2 closed

**Operated Condition (Glass Broken / Button pushes in)**  
 Terminals +(1) & (2) M/S 1 and M/S 2 open  
 Terminals +(1) & -(3) M/S 1 and M/S 2 closed

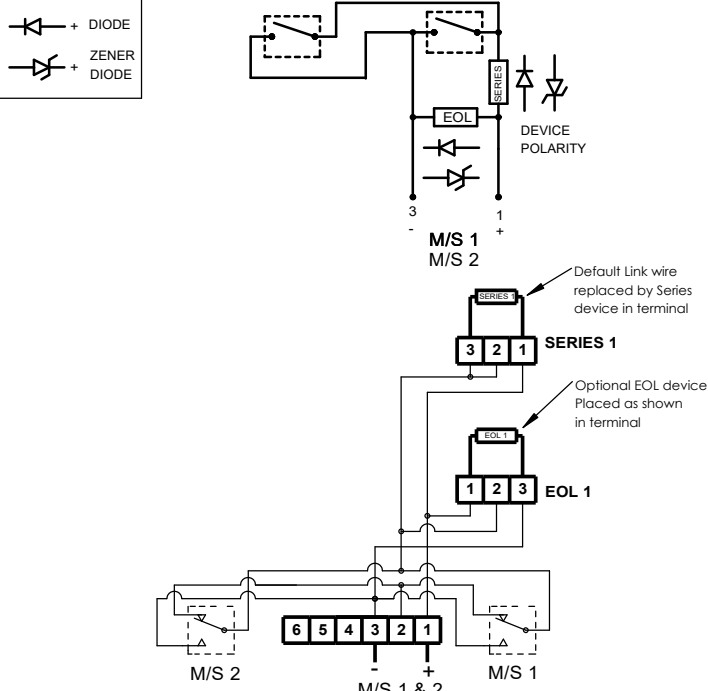

Circuit as shown in Unoperated condition

**Unoperated Condition (Glass Intact / Standby Condition)**  
 Terminals +(1) & -(3) M/S 1 and M/S 2 open  
 Terminals +(1) & (2) M/S 1 and M/S 2 closed

**Operated Condition (Glass Broken / Button pushes in)**  
 Terminals +(1) & (2) M/S 1 and M/S 2 open  
 Terminals +(1) & -(3) M/S 1 and M/S 2 closed

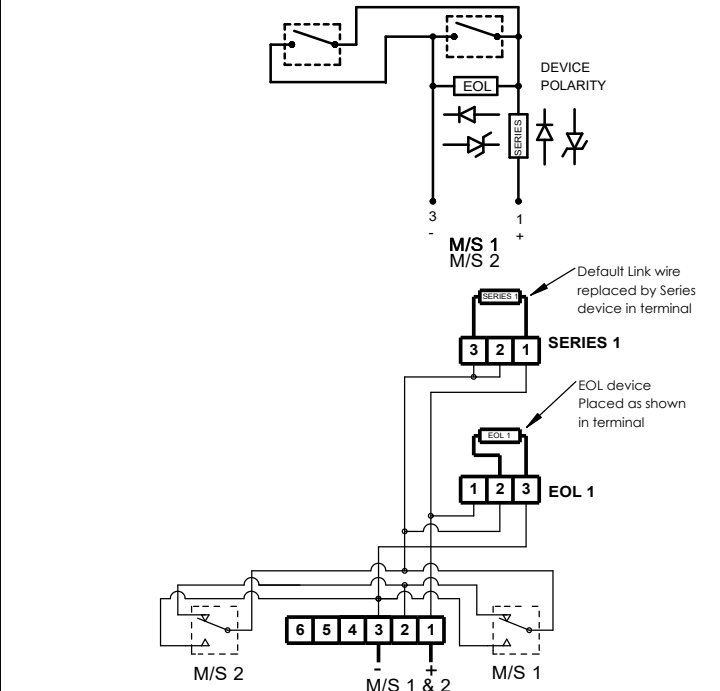

Circuit as shown in Unoperated condition

**Unoperated Condition (Glass Intact / Standby Condition)**  
 Terminals +(1) & -(3) M/S 1 and M/S 2 open  
 Terminals +(1) & (2) M/S 1 and M/S 2 closed

**Operated Condition (Glass Broken / Button pushes in)**  
 Terminals +(1) & (2) M/S 1 and M/S 2 open  
 Terminals +(1) & -(3) M/S 1 and M/S 2 closed

DRAWING TO BS8888:2000  
 GEOMETRIC TOLERANCES TO ISO1101:1983  
 LINEAR DIMENSIONAL TOLS  
 ANGULAR DIMENSIONAL TOLS

STANDARDS  
 GNEXCP7 ; STExCP8 ; WP7 units with PCB

DRAWN	DATE
R.N.POTTS	20-08-2023
CHECKED	DATE
B.ISARD	20-08-2023
APPROVED	DATE
R.N.POTTS	20-08-2023

SURFACE FINISH

WEIGHT (Kg)

MATERIAL

ALTERNATIVE MATERIAL

THIS DRAWING AND ANY INFORMATION OR DESCRIPTIVE MATTER THEREIN IS COMMUNICATED IN CONFIDENCE AND IS THE COPYRIGHT PROPERTY OF EUROPEAN SAFETY SYSTEMS LTD. NEITHER THE WHOLE OR ANY EXTRACT MAY BE DISCLOSED, LOANED, COPIED OR USED FOR MANUFACTURING OR TENDERING PURPOSES WITHOUT THEIR WRITTEN CONSENT.

EUROPEAN SAFETY SYSTEMS LTD.  
 AS PER LATEST DATE OF ISSUE SHOWN ABOVE

**e2s** warning signals  
 EUROPEAN SAFETY SYSTEMS LTD  
 IMPRESS HOUSE  
 MANSELL ROAD  
 ACTON  
 LONDON W3 7QH  
 WWW.E2S.COM

ALL DIMENSIONS IN MM  
 IF IN DOUBT, ASK - DO NOT SCALE

**A3**

TITLE **GNEXCP7 ; STExCP8 ; WP7 CALL POINT WIRING / CIRCUIT OPERATION DIAGRAM**

SCALE	SHEET	DRAWING NUMBER
NTS	7 OF 8	<b>D202-06-212</b>

**DUAL MICROSWITCH IN PARALLEL, LED & DEVICES**

**SHEET 8**

GNEXCP7-BG[s][t][l][e][m][d][v][o][x]-[u][e][s]  
 Switch Type [s] Terminals [t] Product Version [v] Product Option [o] LED Indicator [u] Series Module [s] EOL Module [e]

Module Device Codes		
	EOL	Series
Resistor	ExxxR	SxxxR
Diode	ED1	SD1
Zener Diode	ExxxZ	SxxxZ
LED	N/A	L or C

ISSUE	MOD No.	REASON - INITIAL - DATE
1	ACN0127	INTRODUCTION RNP 20-08-2023
2	ACN0178	LED C and L version clarified ; LED mounted in N/O position on switch RNP 04-04-2025

**DUAL SWITCH PARALLEL WITH LED**

**CONFIG. P8-1**

**DUAL SWITCH PARALLEL WITH LED, EOL & SERIES DEVICES**

**CONFIG. P8-2**

**DUAL SWITCH PARALLEL WITH LED, EOL & ALT. SERIES DEVICES**

**CONFIG. P8-3**

SWITCH TYPE [s] [D]  
 TERMINALS [t] [P]  
 PRODUCT OPTION [o] [P]  
 LED INDICATOR [u] [C] or [L]

Dual PCB Version  
 Parallel Wiring  
 C = LED without RL1

SWITCH TYPE [s] [D]  
 TERMINALS [t] [P]  
 PRODUCT OPTION [o] [P]  
 LED INDICATOR [u] [C] or [L]  
 MODULES [e][s] [Exxxx][Sxxxx]

Dual PCB Version  
 Parallel Wiring  
 C = LED without RL1  
 EOL and/or Series

SWITCH TYPE [s] [D]  
 TERMINALS [t] [P]  
 PRODUCT OPTION [o] [V]  
 LED INDICATOR [u] [C] or [L]  
 MODULES [e][s] [Exxxx][Sxxxx]

Dual PCB Version  
 Parallel Wiring Alt. EOL Pos'n  
 C = LED without RL1  
 EOL and/or Series

Notes - For all LED Options:  
 1) The LED is configured as LED indicator option 'C' for this version the LED must be protected by a series resistor of a minimum value of 1.5K Ohm or by limiting the systems current to 20mA max  
 2) Units have the option to add the LED current-limiting resistor RL1 LED indicator option 'L' which is 1.5K Ohms.  
 3) Note that in both cases the total value of the series resistors and if fitted RL1 will impact the brightness of the LED.

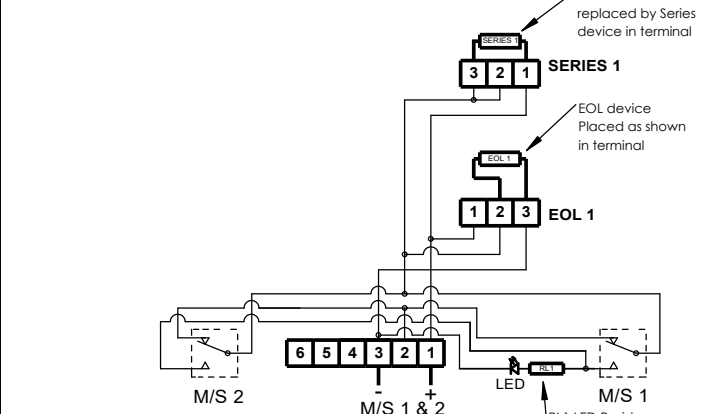
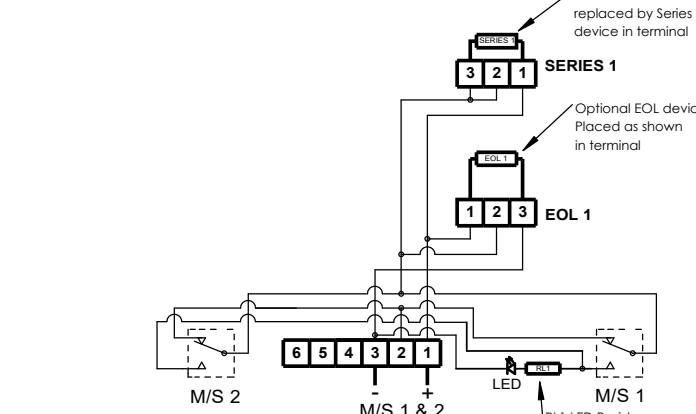
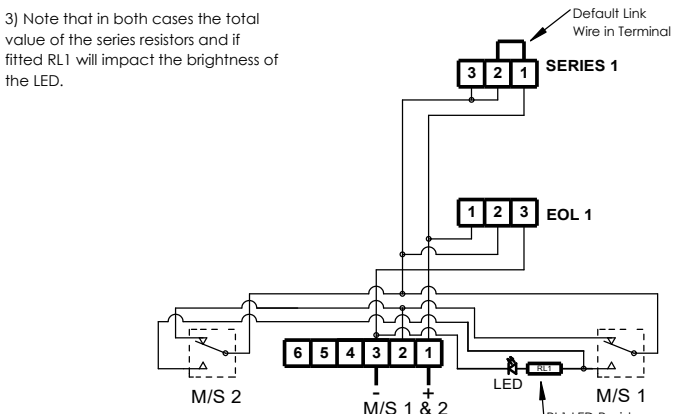
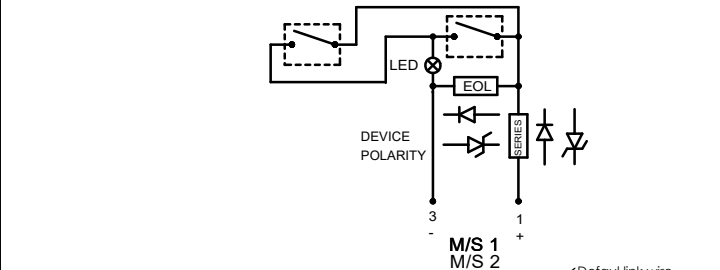
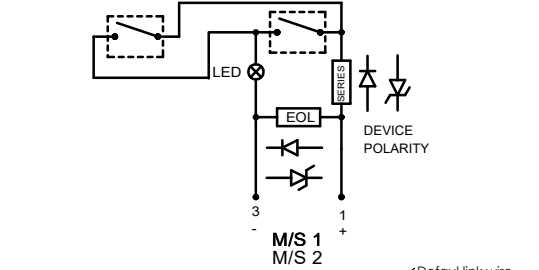
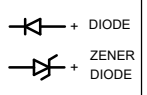
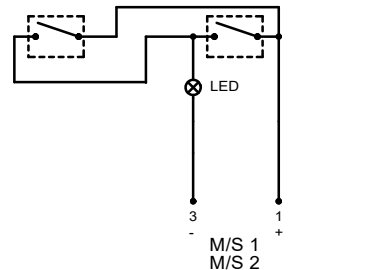

**Circuit as shown in Unoperated condition**

**Unoperated Condition (Glass Intact / Standby Condition)**  
 Terminals +(1) & -(3) M/S 1 and M/S 2 open  
 Terminals +(1) & (2) M/S 1 and M/S 2 closed

**Operated Condition (Glass Broken / Button pushes in)**  
 Terminals +(1) & (2) M/S 1 and M/S 2 open  
 Terminals +(1) & -(3) M/S 1 and M/S 2 closed

**Circuit as shown in Unoperated condition**

**Unoperated Condition (Glass Intact / Standby Condition)**  
 Terminals +(1) & -(3) M/S 1 and M/S 2 open  
 Terminals +(1) & (2) M/S 1 and M/S 2 closed

**Operated Condition (Glass Broken / Button pushes in)**  
 Terminals +(1) & (2) M/S 1 and M/S 2 open  
 Terminals +(1) & -(3) M/S 1 and M/S 2 closed

**Circuit as shown in Unoperated condition**

**Unoperated Condition (Glass Intact / Standby Condition)**  
 Terminals +(1) & -(3) M/S 1 and M/S 2 open  
 Terminals +(1) & (2) M/S 1 and M/S 2 closed

**Operated Condition (Glass Broken / Button pushes in)**  
 Terminals +(1) & (2) M/S 1 and M/S 2 open  
 Terminals +(1) & -(3) M/S 1 and M/S 2 closed

DRAWING TO BS8888:2000  
 GEOMETRIC TOLERANCES TO ISO1101:1983  
 LINEAR DIMENSIONAL TOLS  
 ANGULAR DIMENSIONAL TOLS

STANDARDS  
 GNEXCP7 ; STExCP8 ; WP7 units with PCB

DRAWN DATE  
 R.N.POTTS 20-08-2023

CHECKED DATE  
 B.ISARD 20-08-2023

APPROVED DATE  
 R.N.POTTS 20-08-2023

SURFACE FINISH

WEIGHT (Kg)

MATERIAL

ALTERNATIVE MATERIAL

THIS DRAWING AND ANY INFORMATION OR DESCRIPTIVE MATTER THEREIN IS COMMUNICATED IN CONFIDENCE AND IS THE COPYRIGHT PROPERTY OF EUROPEAN SAFETY SYSTEMS LTD. NEITHER THE WHOLE OR ANY EXTRACT MAY BE DISCLOSED, LOANED, COPIED OR USED FOR MANUFACTURING OR TENDERING PURPOSES WITHOUT THEIR WRITTEN CONSENT.

EUROPEAN SAFETY SYSTEMS LTD.  
 AS PER LATEST DATE OF ISSUE SHOWN ABOVE

**e2s** warning signals  
 EUROPEAN SAFETY SYSTEMS LTD  
 IMPRESS HOUSE  
 MANSFELD ROAD  
 ACTON  
 LONDON W3 7QH  
 WWW.E2S.COM

ALL DIMENSIONS IN MM  
 IF IN DOUBT, ASK - DO NOT SCALE

**A3**

TITLE **GNEXCP7 ; STExCP8 ; WP7 CALL POINT WIRING / CIRCUIT OPERATION DIAGRAM**

SCALE SHEET DRAWING NUMBER  
 NTS 8 OF 8 **D202-06-212**

# EU & UKCA Declaration of Conformity



Manufacturer: European Safety Systems Ltd.  
Impress House, Mansell Road, Acton  
London, W3 7QH  
United Kingdom

Authorised Representative: E2S Warnsignaltechnik UG  
Charlottenstrasse 45-51  
72764 Reutlingen  
Germany

Equipment Type: WP3-BG,  
WP6-PB,  
WP7-PB, WP7-PT, WP7-PM

---

#### Directive 2014/30/EU: Electromagnetic Compatibility Directive (EMC)

Standards applied: EN 61000-6-1:2007  
EN 61000-6-2:2005  
EN 61000-6-3:2007 / A1:2011 / AC: 2012  
EN 61000-6-4:2007 / A1:2011

#### Directive 2006/95/EC (until 19th April 2016) / Directive 2014/35/EU (from 20th April 2016): Low Voltage Directive (LVD)

Standards applied: EN 60947-1:2007+A2:2014

#### Directive 2011/65/EU: Restriction of the use of certain hazardous substances in electrical and electronic equipment (RoHS)

The product and all the components contained within it are in accordance with the restriction of the use of hazardous substances in electrical and electronic equipment, including amendment by Directive 2015/863/EU.

#### Regulation (EC) 1907/2006: Registration, Evaluation, Authorisation and Restriction of Chemicals (REACH)

The product and all the components contained within it are free from substances of very high concern.

#### Other Standards and Regulations

EN 60529:1992+A2:2013 - Degrees of protection provided by enclosures (IP code) – enclosure rated IP66

---

On behalf of European Safety Systems Ltd., I declare that, on the date the equipment accompanied by this declaration is placed on the market, the equipment conforms with all technical and regulatory requirements of the above listed directives, regulations and standards.

This Declaration is issued under the sole responsibility of the manufacturer.

A handwritten signature in black ink, appearing to read 'Martin Streetz'.

Martin Streetz  
Quality Assurance Manager

Document No.: DC-081\_Issue\_C  
Date and Place of Issue: London, 23/11/2022